

**Industrial Maintenance**

# **Belt Drives 1**

**Courseware Sample**

54332-F0

Order no.: 54332-3C  
First Edition  
Revision level: 10/2017

By the staff of Festo Didactic

© Festo Didactic Ltée/Ltd, Quebec, Canada 2017  
Internet: [www.festo-didactic.com](http://www.festo-didactic.com)  
e-mail: [did@de.festo.com](mailto:did@de.festo.com)

Printed in Canada  
All rights reserved  
ISBN 978-2-89789-015-5 (Printed version)  
ISBN 978-2-89789-017-9 (CD-ROM)  
Legal Deposit – Bibliothèque et Archives nationales du Québec, 2017  
Legal Deposit – Library and Archives Canada, 2017

The purchaser shall receive a single right of use which is non-exclusive, non-time-limited and limited geographically to use at the purchaser's site/location as follows.

The purchaser shall be entitled to use the work to train his/her staff at the purchaser's site/location and shall also be entitled to use parts of the copyright material as the basis for the production of his/her own training documentation for the training of his/her staff at the purchaser's site/location with acknowledgement of source and to make copies for this purpose. In the case of schools/technical colleges, training centers, and universities, the right of use shall also include use by school and college students and trainees at the purchaser's site/location for teaching purposes.

The right of use shall in all cases exclude the right to publish the copyright material or to make this available for use on intranet, Internet and LMS platforms and databases such as Moodle, which allow access by a wide variety of users, including those outside of the purchaser's site/location.

Entitlement to other rights relating to reproductions, copies, adaptations, translations, microfilming and transfer to and storage and processing in electronic systems, no matter whether in whole or in part, shall require the prior consent of Festo Didactic.

















Information in this document is subject to change without notice and does not represent a commitment on the part of Festo Didactic. The Festo materials described in this document are furnished under a license agreement or a nondisclosure agreement.

Festo Didactic recognizes product names as trademarks or registered trademarks of their respective holders.











All other trademarks are the property of their respective owners. Other trademarks and trade names may be used in this document to refer to either the entity claiming the marks and names or their products. Festo Didactic disclaims any proprietary interest in trademarks and trade names other than its own.

# Safety and Common Symbols

The following safety and common symbols may be used in this manual and on the equipment:

Symbol	Description
	<b>DANGER</b> indicates a hazard with a high level of risk which, if not avoided, will result in death or serious injury.
	<b>WARNING</b> indicates a hazard with a medium level of risk which, if not avoided, could result in death or serious injury.
	<b>CAUTION</b> indicates a hazard with a low level of risk which, if not avoided, could result in minor or moderate injury.
	<b>CAUTION</b> used without the <i>Caution, risk of danger</i> sign  , indicates a hazard with a potentially hazardous situation which, if not avoided, may result in property damage.
	Caution, risk of electric shock
	Caution, hot surface
	Caution, risk of danger. Consult the relevant user documentation.
	Caution, lifting hazard
	Caution, belt drive entanglement hazard
	Caution, chain drive entanglement hazard
	Caution, gear entanglement hazard
	Caution, hand crushing hazard
	Notice, non-ionizing radiation
	Consult the relevant user documentation.
	Direct current
	Alternating current

# Safety and Common Symbols

Symbol	Description
	Both direct and alternating current
	Three-phase alternating current
	Earth (ground) terminal
	Protective conductor terminal
	Frame or chassis terminal
	Equipotentiality
	On (supply)
	Off (supply)
	Equipment protected throughout by double insulation or reinforced insulation
	In position of a bi-stable push control
	Out position of a bi-stable push control

# Table of Contents

Preface .....	VII
About This Manual .....	IX
To the Instructor .....	XI
<b>Job Sheet 1 Introduction to Belt Drives .....</b>	<b>1</b>
<b>Job Sheet 2 Belt Drive Installation and Pulley Alignment.....</b>	<b>15</b>
<b>Job Sheet 3 Belt Tension and Basic Calculations .....</b>	<b>25</b>
<b>Job Sheet 4 Pitch Diameter, Speed, and Torque Ratios .....</b>	<b>43</b>
<b>Appendix A Post-Test.....</b>	<b>55</b>
<b>Appendix B Equipment Utilization Chart.....</b>	<b>59</b>
<b>Appendix C Lockout/Tagout Procedure .....</b>	<b>61</b>



# Preface

The Mechanical Drives Training System covers the installation, use, maintenance, and troubleshooting of mechanical drives.

The curriculum is divided into levels and covers the following topics:

- Introduction to mechanical drive systems
- Belt drives
- Chain drives
- Gear drives
- Shaft alignment and couplings
- Bearings and seals
- Ball screws and linear bearings
- Clutches and brakes
- Vibration metering and analysis
- Notions of lubrication

The figure below shows the available course material for the Mechanical Drives Training System.

# Preface

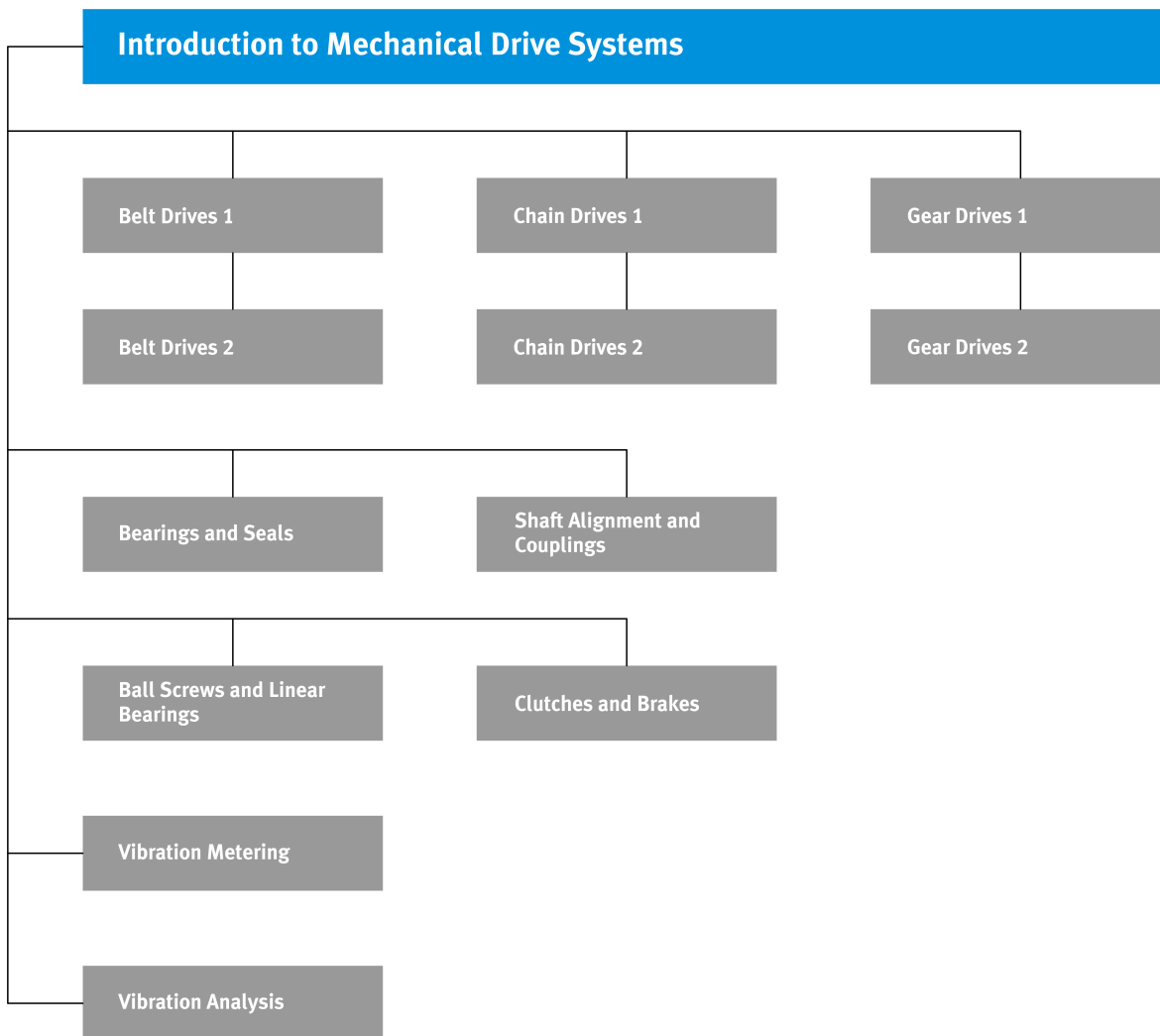

**Mechanical Drives Training System course material.**

We invite readers of this manual to send us their tips, feedback, and suggestions for improving the book.

Please send these to [did@de.festo.com](mailto:did@de.festo.com).

The authors and Festo Didactic look forward to your comments.



# About This Manual

The Belt Drives 1 manual introduces the basics of belt drives. It pertains to the level 1 of the Mechanical Drives Training System curriculum.

The topics covered in this manual are presented in form of Job Sheets. The Job Sheets include a description of the objectives, a list of equipment required, safety procedures, and a list of steps required to attain the objectives.

The topics are usually introduced in an Information Job Sheet. However, to obtain detailed information about the covered topic, you should refer to your text book or ask your instructor to guide your learning process.

## Manual objectives

When you have completed this manual, you will be familiar with belt drives, and their roles in industrial applications. You will know how to properly install belt drives and the importance of following specific protocols. You will be able to identify the main components of the belt drive systems in industrial installations. The experiments follow a logical sequence, permitting you to assimilate the concepts in an efficient way. The experiments have to be performed one after another because the understanding of a given Job Sheet depends on the previous one.

## Safety considerations

Safety symbols that may be used in this manual and on the equipment are listed in the Safety and Common Symbols table at the beginning of the manual.

Safety procedures related to the tasks that you will be asked to perform are indicated in each exercise.

Make sure that you are wearing appropriate protective equipment when performing the tasks. You should never perform a task if you have any reason to think that a manipulation could be dangerous for you or your teammates.

## Prerequisite

As a prerequisite to this course, you should have read the manual titled *Introduction to Mechanical Drive Systems*.

## System of units

Units are expressed using the International System of Units (SI).

## Appendices

The appendices included in this manual are:

- Appendix A: Post-Test, evaluates the knowledge of the topics covered in the Job Sheets.
- Appendix B: Equipment Utilization Chart, shows the equipment used in the Job Sheets.
- Appendix C: Lockout/Tagout Procedure, shows the procedure that must be done to operate the equipment safely.



# To the Instructor

You will find in this Instructor Guide all the elements included in the Student Manual together with the answers to all questions, results of measurements, graphs, explanations, suggestions, and, in some cases, instructions to help you guide the students through their learning process. All the information that applies to you is placed between markers and appears in red.

## **Accuracy of measurements**

The numerical results of the hands-on exercises may differ from one student to another. For this reason, the results and answers given in this manual should be considered as a guide. Students who correctly performed the exercises should expect to demonstrate the principles involved and make observations and measurements similar to those given as answers.

Before a student begins a Job Sheet, ensure that the equipment is in good condition and does not represent any risk when used.

When a student has to complete a setup that is partially already mounted, ensure that the setup corresponds to the job description.

When the jobs are performed in teams, ensure that each student has and installs a padlock when performing the Lockout/Tagout procedure.



Sample  
Extracted from  
Job Sheets - Instructor



## Belt Drive Installation and Pulley Alignment

### OBJECTIVE

- Install a two-pulley belt drive;
- Install the motor pillow block bearings, driven shaft, pulleys, and belt;
- Align the pulleys.

### PROCEDURE

#### Equipment required

Refer to the Equipment Utilization Chart in Appendix B to obtain the list of equipment required for this job.

#### Safety procedures

Before proceeding with this job, make sure to complete the following checklist.

- You are wearing safety glasses.
- You are wearing safety shoes.
- You are not wearing anything that might get caught such as a tie, jewelry, or loose clothes.
- If your hair is long, tie it out of the way.
- The working area is clean and free of oil.
- The floor is not wet.
- Your sleeves are rolled up.

#### Setup

1. Perform the Lockout/Tagout procedure.



*Refer to Appendix C if necessary.*

2. Fix three extrusion bars to the positions shown in Figure 13.



*Make sure that the other extrusion bars present in the workstation are fixed tight at the back of the workstation.*

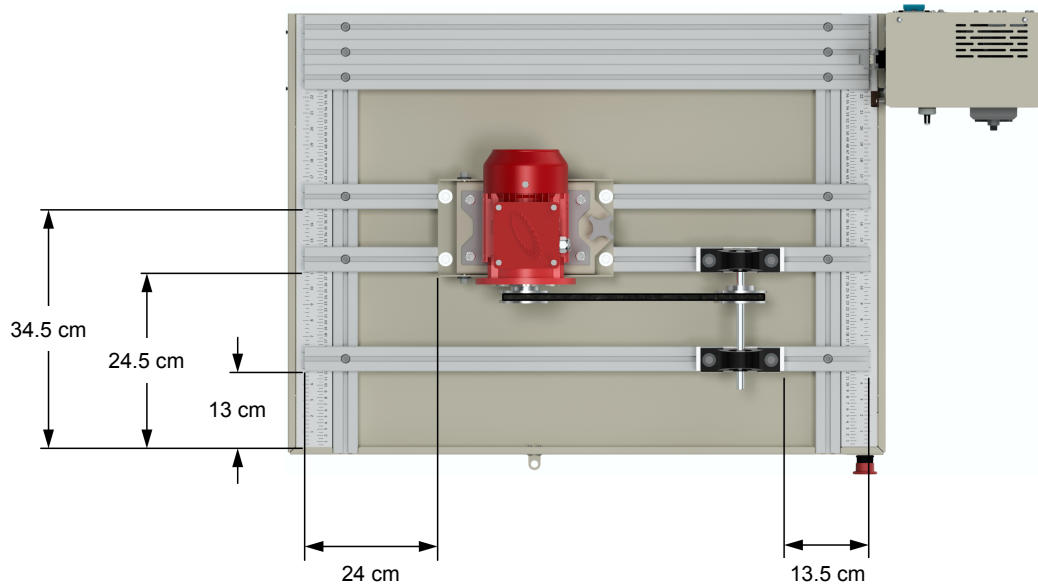

Figure 13. Workstation setup for Job Sheet 2.

3. Install the motor mounting base on the extrusion bars using the M8-1.25 X 16 mm screws, flat washers, and T-nuts as shown in Figure 13. Then tighten the screws with a 6 mm hexagonal T-handle key, following a crisscross pattern.



*It is important that the mounting base level knob is located at your right for proper adjustment of the position and tension.*

4. Fix the motor on the mounting base using the M8-1.25 X 20 mm screws. Tighten the motor screws with a 6 mm hexagonal T-handle key, following a crisscross pattern.
5. Check for motor soft-foot before proceeding further. Apply the corrections if necessary.

### Pulley installation

6. Install a key in the keyseat of the motor shaft. The key should fit snugly on the keyseat with no side-to-side movement.
7. Take the 80 mm nominal D. pulley from the Pulleys panel and slide it on the motor shaft as shown in Figure 14. The pulley hub should be on the motor side.



*Make sure the pulley and motor shaft key are in line with the end of the motor shaft.*



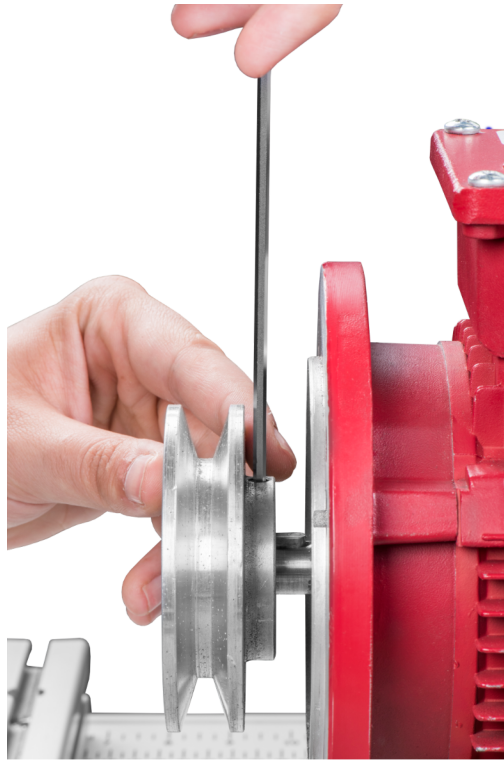

Figure 14. Driving pulley installation.

8. Tighten the pulley setscrew on the shaft key with a 3 mm hexagonal T-handle key.



*Do not overtighten the pulley setscrew.*

9. Install two pillow block bearings and risers on the extrusions using the M8-1.25 x 75 mm screws, flat washers, and T-nuts as shown in Figure 13. Make sure the setscrews on both pillow block bearings are pointing outwards. Do not tighten the screws yet.

10. Take a short shaft from the Couplings-Shafts panel and prepare it using the following procedure. This ensures that the shaft is free of dirt and debris.

- Inspect the shaft for damages and clean up any dirt and debris from the keyway and the shaft.
- Clean up the edge of the keyway using an emery paper or a fine tooth file.
- Using an emery paper, clear the shaft from rust and corrosion.
- Make sure that the surface of the shaft and the keyway are clean of debris using a clothing and a cleaning solvent.



*Perform this procedure each time you install a shaft.*

11. Slide the short shaft through the pillow block bearing located on the same extrusion bar as the motor.
12. Install a key in the keyseat of the shaft supported by the pillow block bearings. The key should fit snugly on the keyseat with no side-to-side movement.
13. Take the 100 mm nominal D. pulley from the Pulleys panel and slide it on the motor shaft. The pulley hub should be on the motor side.



*From now on, the pulley on the short shaft will be referred as the driven pulley.*

14. Wrap the A38 V-Belt around the driven pulley.
15. Wrap the A38 V-Belt around the driving pulley without rolling, bending or pitching it.
16. Slide the short shaft through the other pillow block bearing.



*Make sure the end of the shaft is flush with the end of the hub on the pillow block bearing that is located next to the motor. The shaft can exceed the end of the other pillow block.*

17. Tighten the pillow block bearings setscrews on the flat surface of the shaft with a 3 mm hexagonal T-handle key.

### CAUTION

Do not tighten the setscrew on any surface other than a flat surface. This may damage the components.

### Pulley alignment

*In this job, the pulleys are aligned using the straightedge method. If strings are available in the classroom, it is recommended to test the string method for comparison purposes as well.*

### *Angular alignment*

- 18.** Verify the vertical angular alignment by laying a combination square against the face of the driving pulley as shown in Figure 15. Note the position of the bubble.

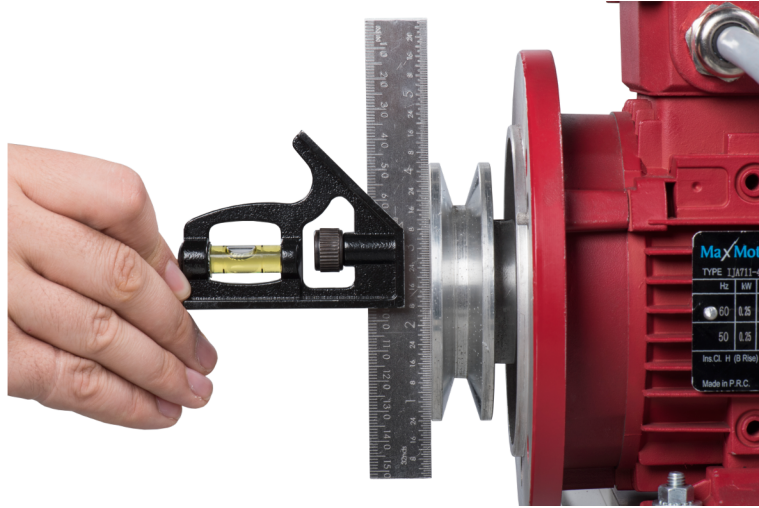

**Figure 15.** Vertical angular alignment.

- 19.** Lay the combination square against the face of the driven pulley and note the position of the bubble.
- 20.** Adjust the vertical angular alignment so that the position of the bubble on the driven pulley coincides with its position on the driving pulley. Insert shims under the pillow block bearings as required.



*The bubble does not need to be perfectly centered, but it must be at the same position for both sprocket.*

- 21.** Verify the horizontal angular alignment by laying a straightedge on the face of both pulleys.

22. Adjust the position of the pillow blocks as shown in Figure 16 until the distances A and B are the same.

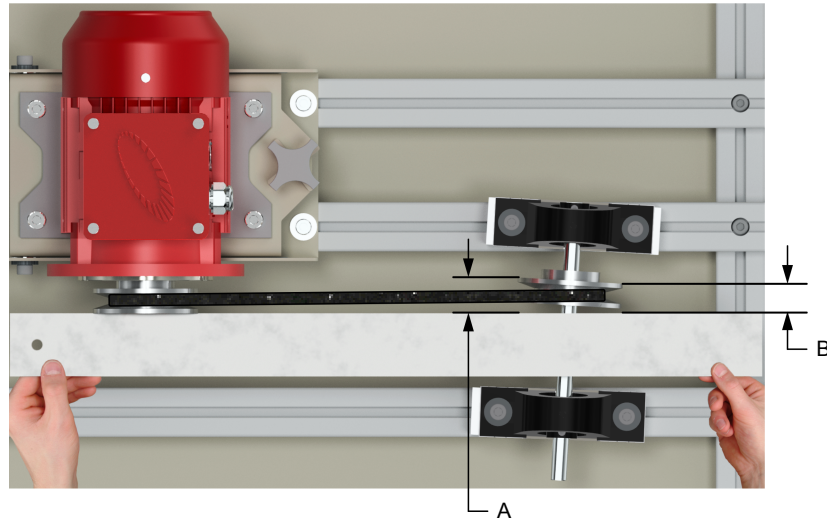

Figure 16. Horizontal angular alignment.

23. Tighten the pillow block bearing screws.

*Parallel alignment*

24. Lay a straightedge against the face of both pulleys and move the driven pulley along the shaft until both pulleys are in contact with the straightedge as shown in Figure 17.

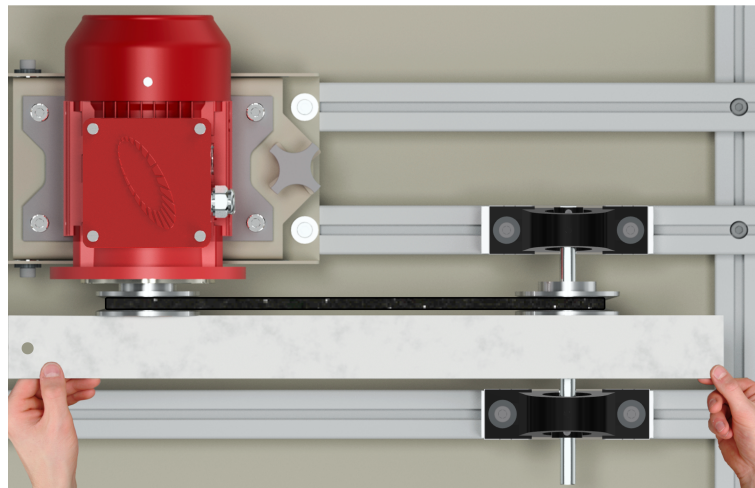

Figure 17. Parallel alignment.

25. Tighten the driven pulley setscrew on the shaft key.



*Do not overtighten the driven pulley setscrew.*

- 26.** Rotate the pulleys half a turn and re-check angular and parallel misalignments.



*Pulley manufacturers usually specify a recommended tolerance for misalignment. It is usually around 0.5°, but you should always refer to the documentation for the precise value.*

- 27.** Connect the motor to the variable frequency drive. To do so, clip the end of the motor connector to the power inlet inside the workstation enclosure.

**CAUTION**

Tuck the motor cable far from the rotating parts so that it does not get damaged when the motor starts.

- 28.** Ask the instructor to check your work.

- 29.** Disassemble the setup and return the components to the storage location.

Name: \_\_\_\_\_ Date: \_\_\_\_\_

Instructor's approval: \_\_\_\_\_

