

Process Control

Measurement - Temperature

Courseware Sample

86009-F0

Order no.: 86009-10
Revision level: 12/2014

By the staff of Festo Didactic

© Festo Didactic Ltée/Ltd, Quebec, Canada 2011
Internet: www.festo-didactic.com
e-mail: did@de.festo.com

Printed in Canada
All rights reserved
ISBN 978-2-89640-460-5 (Printed version)
Legal Deposit – Bibliothèque et Archives nationales du Québec, 2011
Legal Deposit – Library and Archives Canada, 2011

The purchaser shall receive a single right of use which is non-exclusive, non-time-limited and limited geographically to use at the purchaser's site/location as follows.

The purchaser shall be entitled to use the work to train his/her staff at the purchaser's site/location and shall also be entitled to use parts of the copyright material as the basis for the production of his/her own training documentation for the training of his/her staff at the purchaser's site/location with acknowledgement of source and to make copies for this purpose. In the case of schools/technical colleges, training centers, and universities, the right of use shall also include use by school and college students and trainees at the purchaser's site/location for teaching purposes.

The right of use shall in all cases exclude the right to publish the copyright material or to make this available for use on intranet, Internet and LMS platforms and databases such as Moodle, which allow access by a wide variety of users, including those outside of the purchaser's site/location.

Entitlement to other rights relating to reproductions, copies, adaptations, translations, microfilming and transfer to and storage and processing in electronic systems, no matter whether in whole or in part, shall require the prior consent of Festo Didactic GmbH & Co. KG.

















Information in this document is subject to change without notice and does not represent a commitment on the part of Festo Didactic. The Festo materials described in this document are furnished under a license agreement or a nondisclosure agreement.

Festo Didactic recognizes product names as trademarks or registered trademarks of their respective holders.

All other trademarks are the property of their respective owners. Other trademarks and trade names may be used in this document to refer to either the entity claiming the marks and names or their products. Festo Didactic disclaims any proprietary interest in trademarks and trade names other than its own.

Safety and Common Symbols

The following safety and common symbols may be used in this manual and on the equipment:

Symbol	Description
	DANGER indicates a hazard with a high level of risk which, if not avoided, will result in death or serious injury.
	WARNING indicates a hazard with a medium level of risk which, if not avoided, could result in death or serious injury.
	CAUTION indicates a hazard with a low level of risk which, if not avoided, could result in minor or moderate injury.
	CAUTION used without the <i>Caution, risk of danger</i> sign  , indicates a hazard with a potentially hazardous situation which, if not avoided, may result in property damage.
	Caution, risk of electric shock
	Caution, hot surface
	Caution, risk of danger
	Caution, lifting hazard
	Caution, hand entanglement hazard
	Notice, non-ionizing radiation
	Direct current
	Alternating current
	Both direct and alternating current
	Three-phase alternating current
	Earth (ground) terminal

Safety and Common Symbols









Symbol	Description
	Protective conductor terminal
	Frame or chassis terminal
	Equipotentiality
	On (supply)
	Off (supply)
	Equipment protected throughout by double insulation or reinforced insulation
	In position of a bi-stable push control
	Out position of a bi-stable push control

Table of Contents

Preface	IX
To the Instructor	XIII
Unit 1	Introduction to Measurement 1
	DISCUSSION OF FUNDAMENTALS 1
	Measurement..... 1
	What is measurement? 1
	Observable variable 1
	Measuring instrument..... 2
	Units 2
	Pressure, flow, and level measurement units..... 2
	Dimensions and units 3
Unit 2	Measuring Instruments 7
	DISCUSSION OF FUNDAMENTALS 7
	General Characteristics 7
	Range 7
	Span..... 7
	Rangeability 8
	Sensitivity..... 8
	Errors 8
	Accuracy of the instrument..... 9
	Precision 9
	Accuracy 9
	A good measuring instrument 9
	Expressing the maximum error of an instrument..... 10
	Dynamic characteristics of an instrument 11
Unit 3	Temperature Measurement..... 17
	DISCUSSION OF FUNDAMENTALS 17
	Temperature 17
	Energy 17
	Kinetic energy 18
	Gravitational potential energy 18
	Internal energy 19
	Temperature and temperature scales 19
	Fahrenheit..... 20
	Celsius 20
	Kelvin 21
	Rankine..... 22
	Standard temperature and pressure (STP)..... 22

Table of Contents

	Thermal equilibrium.....	22
	Thermometric properties	23
	Temperature measurement.....	24
	Thermometers	25
	Thermodynamics	26
Ex. 3-1	Resistance Temperature Detectors (RTDs).....	29
	DISCUSSION.....	29
	Introduction.....	29
	Electrical Resistance	29
	RTD metals.....	31
	Measurement with an RTD.....	32
	Advantages and limitations	33
	PROCEDURE	34
	Setup and connections.....	34
	Temperature measurement and probe characterization	37
Ex. 3-2	Thermocouples	41
	DISCUSSION.....	41
	The Peltier-Seebeck effect	41
	Thermocouples	43
	Types of thermocouples	43
	Thermocouple protection.....	45
	Measurement of the voltage generated by a thermocouple....	45
	Thermocouple sensitivity to noise	47
	Advantages and limitations of thermocouples.....	47
	PROCEDURE	49
	Setup and connections.....	49
	Temperature measurement and probe characterization	52
Unit 4	Heat Exchanges	61
	DISCUSSION OF FUNDAMENTALS	61
	Heat	61
	Heat units	62
	Heat transfer mechanisms	63
	Conduction	63
	Convection	65
	Radiation	66
	Specific heat.....	68
	Latent heat.....	69

Table of Contents

Ex. 4-1	Basic Thermal Energy Transfer with a Heat Exchanger	71
	DISCUSSION.....	71
	Heat exchangers	71
	Braze plate heat exchanger	72
	PROCEDURE	74
	Set up and connections	74
	Heat exchange balance – Counter-flow configuration	77
	Heat exchange balance – Parallel-flow configuration	79
	Appendix A Conversion Table	89
	Index	91
	Bibliography	93

Preface

Automated process control offers so many advantages over manual control that the majority of today's industrial processes use it to some extent. Breweries, wastewater treatment plants, mining facilities, and the automotive industry are just a few industries that benefit from automated process control systems.

Maintaining process variables such as pressure, flow, level, temperature, and pH within a desired operating range is of the utmost importance when manufacturing products with a predictable composition and quality.

The Instrumentation and Process Control Training System, series 353X, is a state-of-the-art system that faithfully reproduces an industrial environment. Throughout this course, students develop skills in the installation and operation of equipment used in the process control field. The use of modern, industrial-grade equipment is instrumental in teaching theoretical and hands-on knowledge required to work in the process control industry.

The modularity of the system allows the instructor to select the equipment required to meet the objectives of a specific course. Two mobile workstations, on which all of the equipment is installed, form the basis of the system. Several optional components used in pressure, flow, level, temperature, and pH control loops are available, as well as various valves, calibration equipment, and software. These add-ons can replace basic components having the same functionality, depending on the context. During control exercises, a variety of controllers can be used interchangeably depending on the instructor's preference.

We hope that your learning experience with the Instrumentation and Process Control Training System will be the first step toward a successful career in the process control industry.

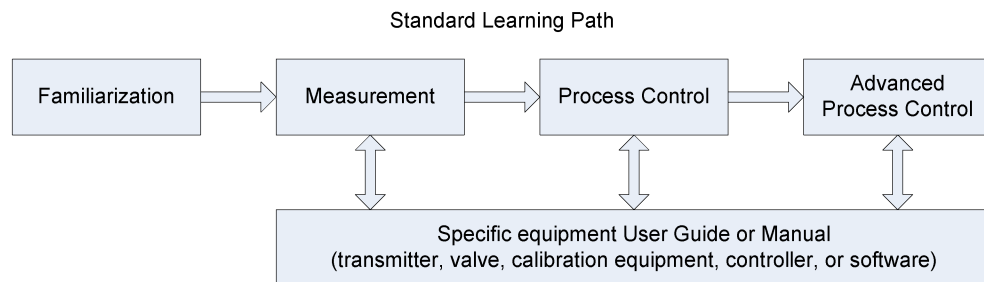

Preface

Manuals of the 353X Series

Pressure/Flow/Level

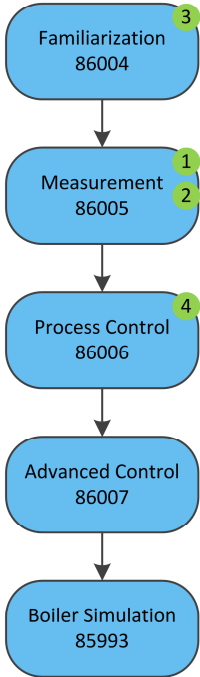

Temperature

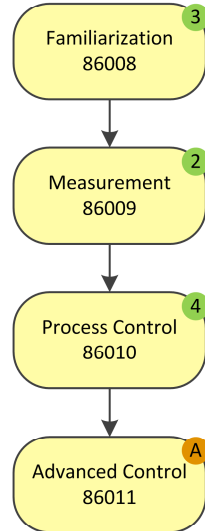

pH and Conductivity

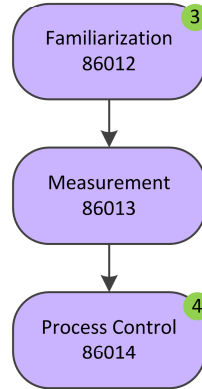

Pressure/Flow (Air)

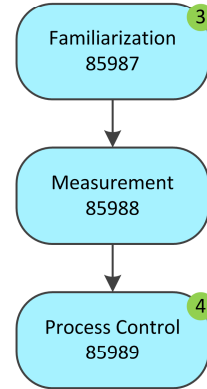

How to read this chart

- Refer to optional manuals below, if required.
- This optional manual is required at this point.

1 Pressure/Flow/Level Add-Ons

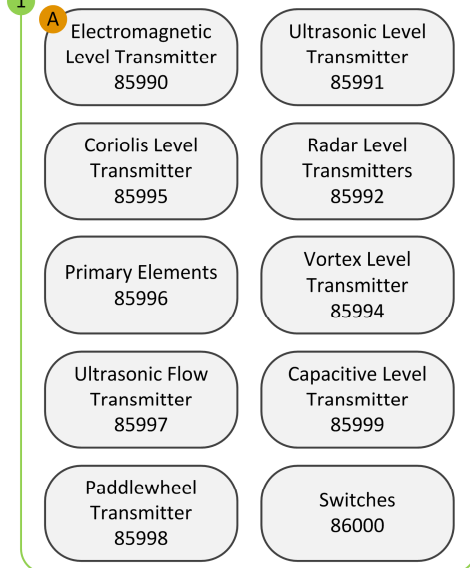

2 Final Elements



3 Communication Protocols

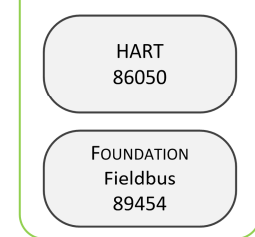

4 Controller/HMI Options

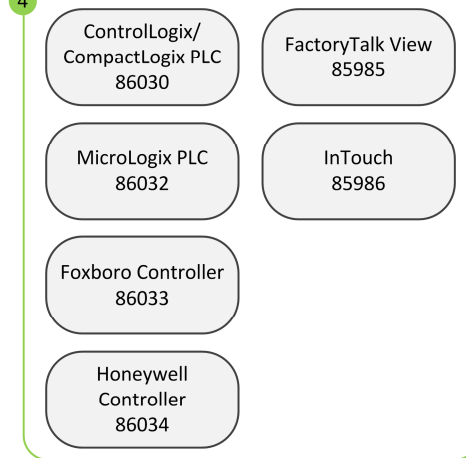

Preface

Do you have suggestions or criticism regarding this manual?

If so, send us an e-mail at did@de.festo.com.

The authors and Festo Didactic look forward to your comments.

To the Instructor

You will find in this Instructor Guide all the elements included in the Student Manual together with the answers to all questions, results of measurements, graphs, explanations, suggestions, and, in some cases, instructions to help you guide the students through their learning process. All the information that applies to you is placed between markers and appears in red.

Accuracy of measurements

The numerical results of the hands-on exercises may differ from one student to another. For this reason, the results and answers given in this manual should be considered as a guide. Students who correctly performed the exercises should expect to demonstrate the principles involved and make observations and measurements similar to those given as answers.

Equipment installation

In order for students to be able to perform the exercises in the Student Manual, the Process Control Training Equipment - Temperature must have been properly installed, according to the instructions given in the user guide Familiarization with the Instrumentation and Process Control System - Temperature, part number 86008-E.

Sample Exercise
Extracted from
the Student Manual
and the Instructor Guide

Thermocouples

EXERCISE OBJECTIVE

When you have completed this exercise, you will be familiar with the mode of operation of thermocouples and you will be able to describe the relationship between the temperature and the voltage generated by a thermocouple. The different types of thermocouples, the methods of temperature measurement, and their advantages and limitations will have been described.

DISCUSSION OUTLINE

The Discussion of this exercise covers the following points:

- The Peltier-Seebeck effect
- Thermocouples
 - Types of thermocouples. Thermocouple protection.*
- Measurement of the voltage generated by a thermocouple
- Thermocouple sensitivity to noise
- Advantages and limitations of thermocouples

DISCUSSION

The Peltier-Seebeck effect

The **Peltier-Seebeck effect**, also known as the thermoelectric effect, describes the relationship between the electricity generated in a conductor and the temperature difference to which the conductor is subjected. The gradient of temperature causes the displacement of charge carriers (i.e., the electrons or electron holes) by diffusion from one end of the conductor to the other. Historically, the Seebeck and the Peltier effects were seen as two distinct phenomena. They are in fact two reciprocal statements of the same mechanism – This was shown by William Thomson (Lord Kelvin).



Figure 3-21. Thomas Johann Seebeck.

The Seebeck effect, discovered in 1821 by the German-Estonian physicist Thomas Johann Seebeck (1770-1831), states that if two wires made of dissimilar metals are joined at both ends and one of the junctions is heated, a current will flow through the wires. See Figure 3-22.

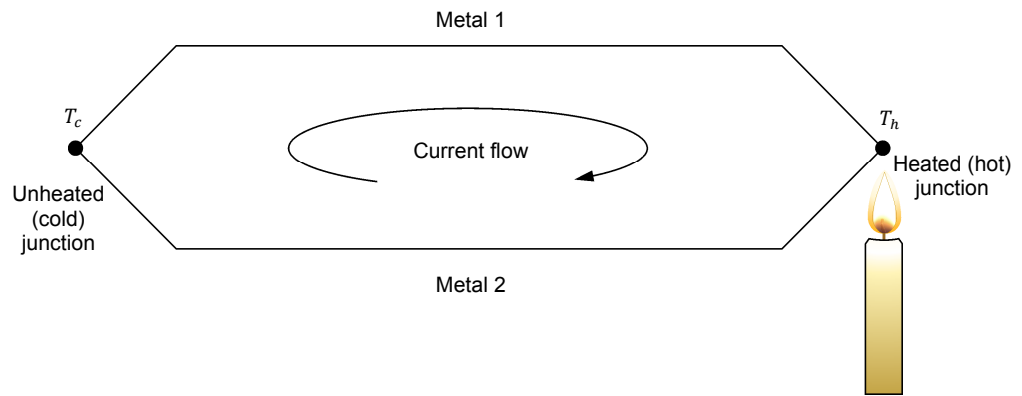

Figure 3-22. The Seebeck effect, part I.

Equivalently, if the circuit is open at the cold (unheated) junction, a voltage (the **Seebeck voltage**) will appear across the open ends of the circuit. See Figure 3-23. The higher the temperature difference is between the hot (heated) junction and the open ends of the wires, the higher the Seebeck voltage will be:

$$V_{Seebeck} = S(T_h - T_c) \quad (3-8)$$

where $V_{Seebeck}$ is the Seebeck voltage across the open ends of the circuit
 S is the Seebeck coefficient
 T_h is the temperature at the hot junction (i.e., the process temperature)
 T_c is the temperature at the cold junction (i.e., the temperature at the open ends of the thermocouple)

The Seebeck coefficient S varies not only with the choice of metals constituting the thermocouple but with the temperature also (i.e., $S = S(T, metal_1, metal_2)$). This makes the relationship described by Equation (3-8) non linear.

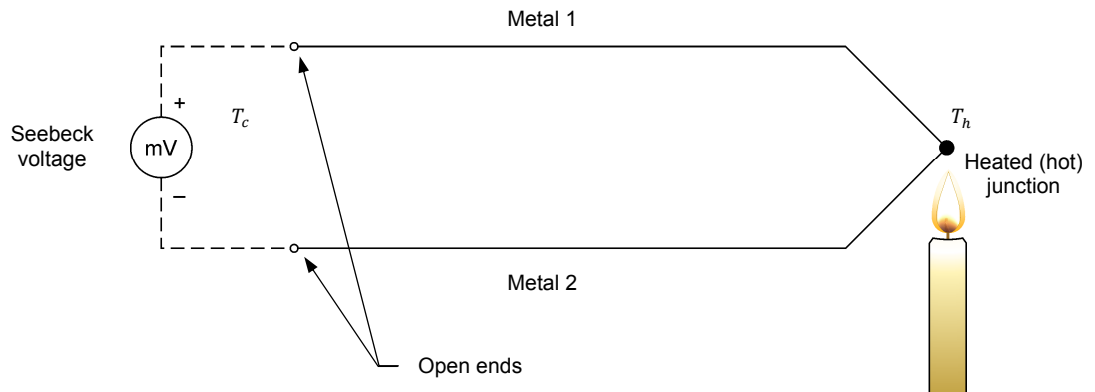

Figure 3-23. The Seebeck effect, part II.

The Seebeck effect is a central principle in temperature measurement: it forms the basis of the use of thermocouples.



Figure 3-24. Jean-Charles Athanase Peltier.

The Peltier effect, discovered in 1834 by the French physicist Jean-Charles Athanase Peltier (1785-1845), describes how an electric current flowing in a circuit made of two different metals causes heat to be generated at one of the junctions while heat is absorbed at the other junction. This effect can be put to use to create a Peltier cooler/heater.

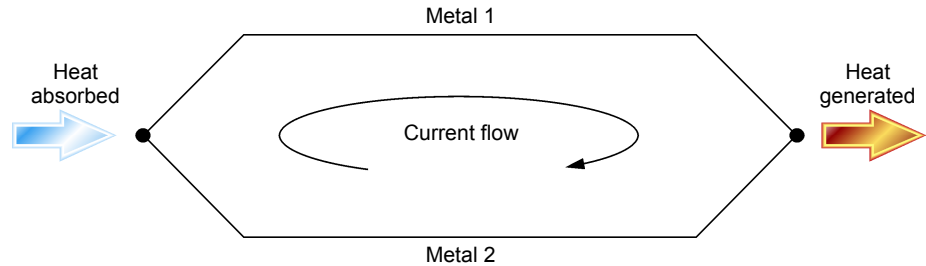

Figure 3-25. The Peltier effect.

Thermocouples

A thermocouple is a primary element that is used to measure temperature. It consists of a pair (i.e., a couple) of wires made of dissimilar metals or alloys which are joined at one end to form a junction.

When a temperature difference exists between the junction and the open ends of the wires (as in Figure 3-23), a small voltage, typically of a few millivolts, is generated across the open ends due to the Peltier-Seebeck effect. The magnitude of the Seebeck voltage is dependent upon the composition of the wires and upon the temperature difference between the junction and the open ends of the wires.

Types of thermocouples

There are several types of thermocouples in the industry. Each type is identified by a letter that refers to a specific selection of two metals. Consequently, each letter corresponds to a specific voltage-temperature relationship.

Figure 3-26 shows relationships between the junction temperature and the generated voltage for the most common types of thermocouples. The temperature of the junction is obtained by measuring the Seebeck voltage and using the appropriate relationship of Figure 3-26 to infer the temperature. The thermocouple operates with a reference temperature of 0°C (32°F) for which the voltage is null. The reference temperature is chosen to coincide with the melting point of ice.

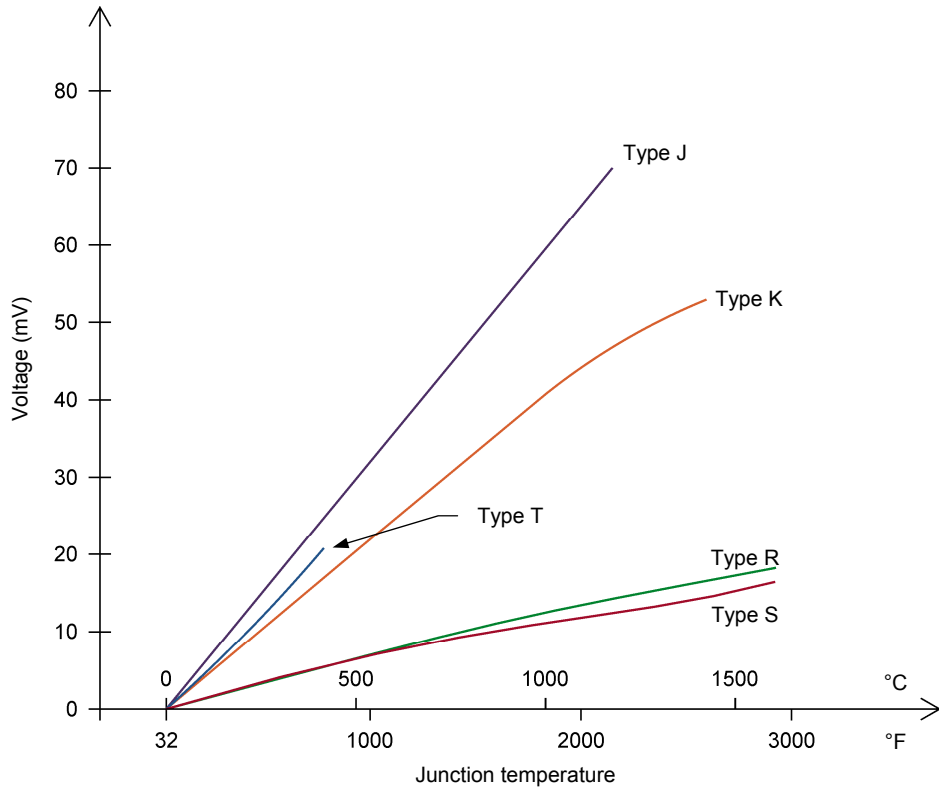

Figure 3-26. Voltage-temperature relationships for common types of thermocouples.

Figure 3-26 shows that different types of thermocouple have different temperature ranges and different sensitivities. A J-type thermocouple will produce a much higher Seebeck voltage at a temperature of 1000°C (~1800°F) than an R-type thermocouple. The R-type thermocouple will be able to measure temperatures above 1500°C (2700°F) whereas this is impossible with a J-type thermocouple. Note also that some relationships are far from linear. All these factors must be taken into account when deciding which type of thermocouple to use for a specific setup.

Each type of thermocouple is made from a specific combination of two different metals or alloys for the wire composition. The most common types are listed in the table below along with their composition. Note that the first element named in a pair is the positive element (e.g., copper is the positive element in a T-type thermocouple, see Figure 3-27 for an example).

Table 3-3. Common types of thermocouples used in the industry.

Thermocouple type	Composition of the two wires
J	Iron – Constantan
K	Chromel – Alumel
R or S	Platinum – Platinum-Rhodium alloy ⁸
T	Copper - Constantan

⁸ An R-type thermocouple is made of a platinum wire and of a wire made from an alloy of 87% platinum/13% rhodium. An S-type thermocouple is made of a platinum wire and of a wire made from an alloy of 90% platinum/10% rhodium. This seemingly small difference in alloy composition is sufficient to result in the different curves for R and S-type thermocouples shown in Figure 3-26.

Constantan is often used as a component of thermocouples. It is a metal alloy, typically made of around 55% copper and 45% nickel.

Thermocouple protection

The thermocouple wires are usually covered by a thermal insulating material and a sheath to prevent the wires from being exposed to the process environment. Consequently, only the junction is exposed to the process. In our case, a thermowell is used to protect the probe further and to allow simple on-the-fly replacement of probes on the process.

A thermocouple junction is designed in one of three different ways:

- **Bared design:** The thermocouple junction protrudes out of the tip of the sheath so as to be directly exposed to the process. This design provides the best response time, but offers no protection from hazardous or corrosive materials. Moreover, this design cannot be used in conjunction with conductive process fluids.
- **Ungrounded design:** The thermocouple junction is covered by the sheath, but it is insulated from the sheath by insulating material. This design can be used in corrosive processes, but it provides a slower response time than the bared design.
- **Grounded design:** The thermocouple junction is covered by the sheath and is in direct contact with the sheath. This ensures a good thermal energy transfer between the process and the junction. This design can be used in corrosive processes and it provides a faster response time than the ungrounded design.

Thermocouples are sometimes installed in a protecting tube made of stainless steel or an alloy that is called a **thermowell**. This is the case in our experiments. The thermowell allows the thermocouple to be easily inserted or removed from the process without any need to stop the process to do so. Moreover, the thermowell protects the probe further against corrosive or hazardous materials. Note however that a thermowell increases the global response time of the probe. This is due to the thermal resistance added by the thermowell to the probe – i.e., the thermowell insulates thermally the probe from the process, causing longer delays before equilibrium is reached.

Measurement of the voltage generated by a thermocouple

By measuring the voltage produced by a thermocouple, a signal proportional to the temperature of the thermocouple junction can be obtained. This signal can be conditioned to make it suitable for instrumentation and control. This is done by normalizing its range and transforming the original signal into current, voltage, or pressure.

The voltage generated by a thermocouple can be related to a measured junction temperature thanks to the voltage-temperature relationship of the thermocouple. This relationship is given by the manufacturer as a curve, a table, or an empirical equation.

Unfortunately, the measurement of the voltage produced by a thermocouple is not as simple as it might seem. This is so because the connection of a voltmeter to a thermocouple creates two additional junctions that result in unwanted, parasitic voltages (when the metals or alloys that meet at these new junctions are dissimilar).

Figure 3-27 shows an example, in which a voltmeter is connected directly across a T-type thermocouple. The objective is to measure voltage V_1 with the voltmeter in order to determine the temperature at which junction J_1 is.

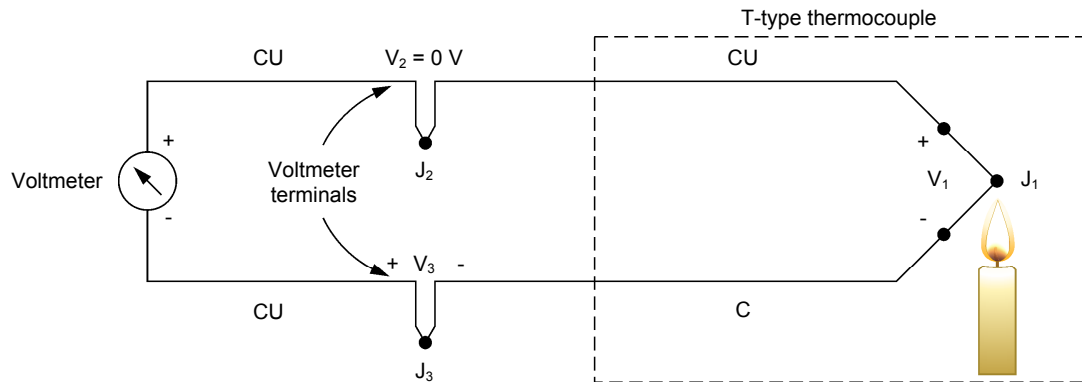

Figure 3-27. Measuring the Seebeck voltage with a voltmeter.

The thermocouple wires are respectively made of copper and constantan, while the terminals of the voltmeter are both made of copper. The points where the voltmeter terminals and the thermocouple wires meet produce two additional junctions, J_2 and J_3 :

- Junction J_2 is a copper-to-copper junction, so that it produces no unwanted parasitic voltage. Consequently, $V_2 = 0\text{ V}$.
- Junction J_3 , however, is a copper-to-constantan junction. It therefore produces an unwanted parasitic voltage, V_3 , due to the Peltier-Seebeck effect. This voltage is subtracted from voltage V_1 when the voltmeter makes a measurement (i.e., $V_{\text{voltmeter}} = V_1 - V_3$). Consequently, the voltmeter reading is proportional to the temperature difference between J_1 and J_3 , not to J_1 only (i.e., $V_{\text{voltmeter}} = V_1 - V_3 = S(T_{J_1} - T_0) - S(T_{J_3} - T_0) = S(T_{J_1} - T_{J_3}) \propto T_{J_1} - T_{J_3}$, where T_0 is the temperature at the open ends).

One way to solve the problem is to determine the exact temperature of J_3 first. Based on the voltage-temperature relationship for J_3 , the voltage contribution from that junction can be determined and added to the measured voltage in order to find the voltage generated by junction J_1 only. This method is however not very practical and is consequently seldom used.

A more practical approach consists in establishing J_3 as the **reference junction**. This can be done using one of the following methods:

- One method is to force junction J_3 at a constant, well-known temperature. This is usually done by putting J_3 into an ice bath at 0°C (32°F), as shown in Figure 3-28a. In this way, the voltmeter reading is referenced to 0°C (32°F) and can be converted directly into temperature by referring to the thermocouple voltage-temperature relationship. The voltage-temperature relationship is itself, as previously mentioned, referenced to 0°C (32°F).

It is a very common practice to hold J_3 at the ice point reference temperature of 0°C (32°F). Consequently, J_3 is usually referred to as the **cold junction**. If for some reason J_3 cannot be set at this temperature, the voltage-temperature relationship can still be used by applying a correction factor to the readings of the voltmeter.

- Another method consists in using a variable dc voltage source to electronically simulate an ice point reference at J_3 . This method is illustrated in Figure 3-28b. The temperature of J_3 is sensed by either an RTD or a thermistor. Based on the sensed temperature, the source generates the compensation voltage required to balance the voltmeter reading as if J_3 were placed in an ice bath at 0°C (32°F). In this way, the voltmeter reading can be converted directly into temperature by referring to the thermocouple voltage-temperature relationship. This method is often referred to as **electronic cold junction compensation**.

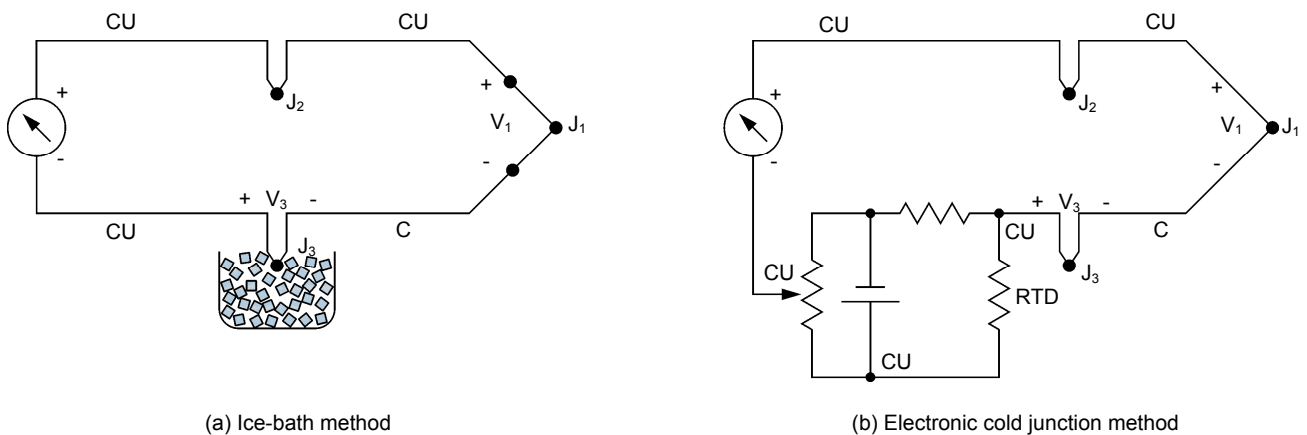

Figure 3-28. Establishing J_3 as the reference junction.

Thermocouple sensitivity to noise

Since the voltage generated by a thermocouple is very small, its measurement is very sensitive to noise. The wires of the thermocouple act like antennas that pick up noise from the environment. Consequently, typical noise sources such as nearby electrical wiring or capacitive grounds can seriously affect temperature measurements.

It is therefore important that the circuit used to condition the thermocouple signal be well shielded and as noise-free as possible. To further reduce noise, the signal can be passed through a low-pass RC filter of proper cut-off frequency. For example, a 4 Hz filter can be useful to remove power line noises that may occur in plants or laboratories.

Advantages and limitations of thermocouples

Thermocouples are used extensively in process control machinery as temperature measurement devices in furnaces and ovens. They are simple, rugged, and relatively inexpensive. They usually have a wider temperature range and a faster response time than RTDs.

However, thermocouples are more sensitive to noise than RTDs. Moreover, they require a reference for accurate temperature measurement because of the unwanted parasitic voltage due to the additional junctions created by the leads of the meter used to measure the voltage. RTDs are also generally more precise than thermocouples.

PROCEDURE OUTLINE

The Procedure is divided into the following sections:

- Setup and connections
- Temperature measurement and probe characterization

PROCEDURE

Setup and connections

1. Verify that the emergency push-button is wired so as to be able to cut the power in case of emergency.
2. Make sure the 3531 system is properly set up to use the Heating/Cooling unit. The system should also be in its basic setup configuration (Refer to the Familiarization manual for details).

Power up the electrical unit and start the drives 3 and 4 (pumps P3 and P4). These pumps make the water of the two tanks flow in the Heating/Cooling unit. Ensure the process fluid from each tank is circulating correctly, then power up the heating/cooling unit. Make sure valve HV7 is closed. Continue with the next steps while the water in each tank is respectively heating and cooling towards their temperature set points.

3. Connect the equipment as the piping and instrumentation diagram of Figure 3-19 shows and use Figure 3-20 to position the equipment correctly on the frame of the training system. Table 3-2 lists the equipment that must be added to the basic setup to perform this exercise. Note that drives and pumps 3 and 4 must be connected to the setup as explained in the familiarization manual, even though they are not shown explicitly in Figure 3-29.

Note how a T-shaped connector is used to split the flow of water returning to tanks A and B – One end leads to valve HV4A while the middle part of the T-shaped connector points in the direction of side B and allows the fluid to travel up to valve HV4B.

Table 3-4. Devices required for this exercise.

Name	Model	Identification
Thermocouple probe (type J)	46916	TE 1
Temperature transmitter	46940	TIT 1

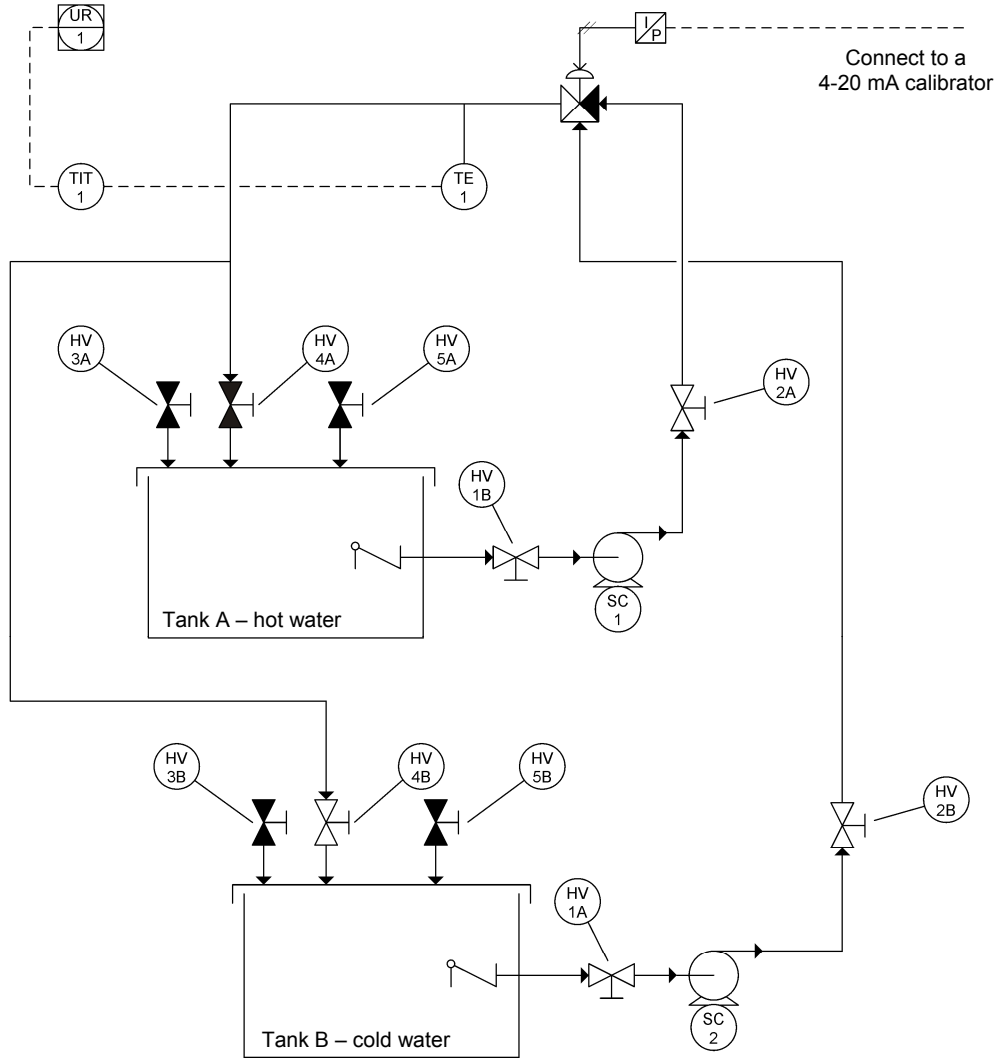

Figure 3-29. P&ID – Thermocouple measurement and characterization.

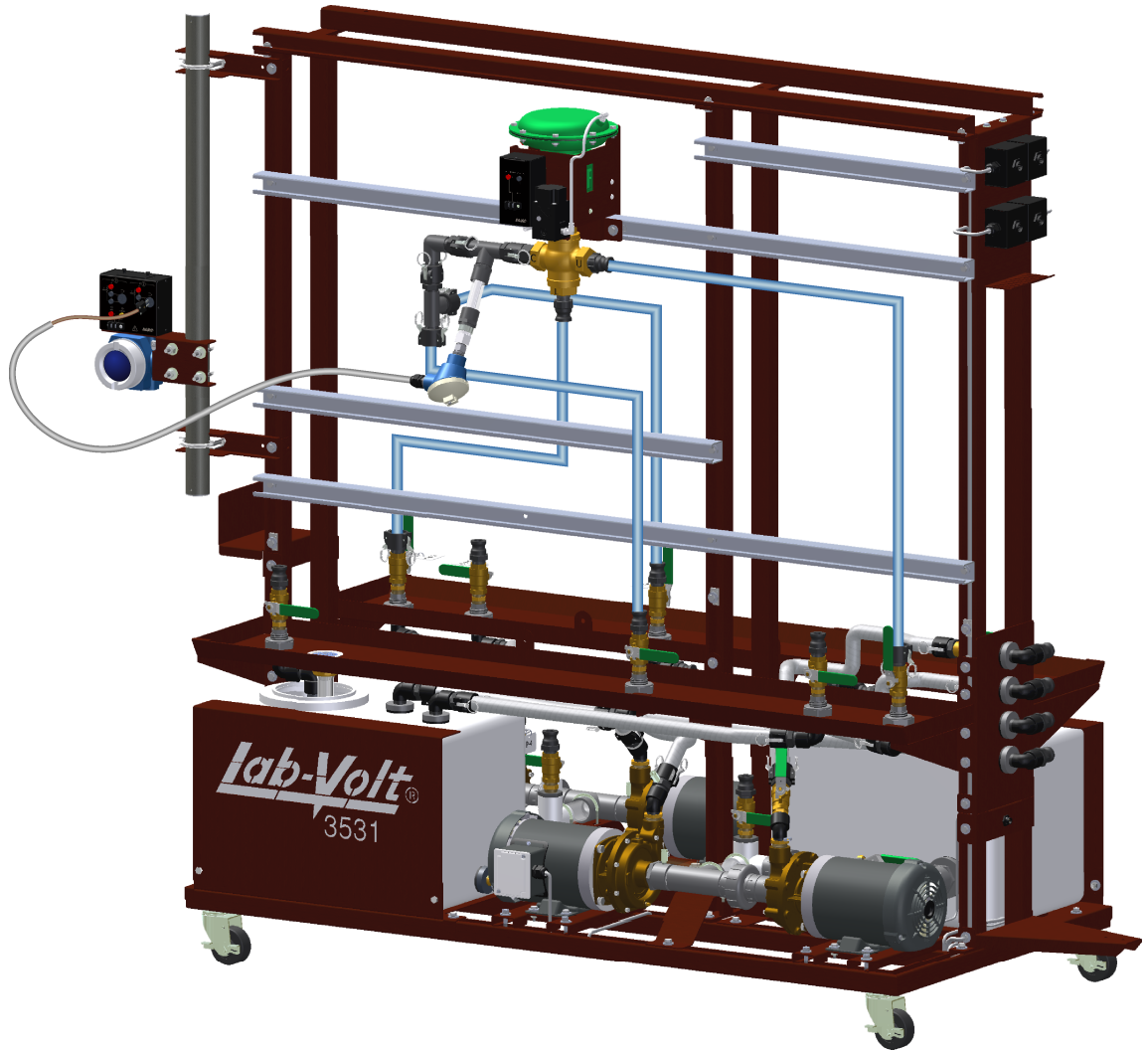

Figure 3-30. Setup - P&ID – Thermocouple measurement and characterization.

4. Connect the pneumatic unit to a dry-air source with an output pressure of at least 700 kPa (100 psi). Activate the pneumatic panel.
5. Connect the I/P converter of the three-way control valve to the pneumatic unit.
6. Test the three-way control valve with a calibrator and make sure it is fully open on L for a 4 mA signal and fully-open on U for a 20 mA signal.

Keep sending a 4 mA signal to the valve so the cold water will be able to circulate in the process loop and will be in thermal contact with the thermocouple probe.

Valve HV4B should be open to allow the cold water to return to its tank. Valve HV4A should consequently be closed so as to avoid filling the hot water tank with cold water.

7. Use the temperature transmitter to display the temperature measured by the thermocouple. Connect the analog output of the transmitter to the paperless recorder.

The measured temperature should be close to the room temperature at this step of the exercise.

Configure the paperless recorder so it displays and records the temperature of the process.

8. Before proceeding further, complete the following checklist to make sure you have set up the system properly. The points on this checklist are crucial elements to the proper completion of this exercise. This checklist is not exhaustive, so be sure to follow the instructions in the *Familiarization with the Instrumentation and Process Control Training System* manual as well.



- Every piece of equipment used is secured to the station with the appropriate bolt-and-nut mechanism.
- The ball valves are in the positions shown in the P&ID and listed below:
Open valves: HV1A, HV1B, HV2A, HV2B, HV4B, HV8A, and HV8B.
Closed valves: HV3A, HV3B, HV4A, HV5A, HV5B, HV6A, HV6B, and HV7.
- The pneumatic connections are correct.
- The paperless recorder is connected correctly to plot the temperature of the process on channel 1.

9. Test your system for leaks. Use drives 1 and 2 to make pumps P1 and P2 run at low speed to produce a small flow rate. Progressively increase the frequency output of drives 1 and 2 up to 30 Hz. Repair any leak.
10. The temperature in the two tanks should be stable and at their respective set points by now. If it is not the case, identify the problem or wait until the temperature of each tank stabilizes.

Temperature measurement and probe characterization

11. Cold water flows around the thermocouple probe in the current setup. Wait until the signal recorded on the paperless recorder is stable. The measured temperature should be close to the temperature of the water in the cold tank.

Temperature of the cold water as measured by the thermocouple:

The next step will be to replace the cold water circulating in the process loop by warm water from the other tank in order to:

- Measure the temperature of the warm water
- Characterize the thermocouple reaction time

CAUTION

The next step must be performed quickly as there is some potential for a water spill if the correct valves are not operated diligently. Read and understand the instructions of step 12 completely before starting the manipulations.

The temperature measured by the thermocouple probe as cold water circulates in the process loop was 14.3°C (57.7°F).



This value is given as an example and depends on the set point programmed in the cooling unit and of course on the actual temperature in the tank. Our set point for the cold water was 18.3°C (65°F) while the temperature in the tank was somewhat colder than the set point at 13.9°C (57°F).

- 12.** Clear the memory of the paperless recorder to get rid of previous data. Record the temperature measured by the thermocouple for a few seconds and then perform a temperature step change on the process:

Close valve HV4B to stop the flow of cold water going back to the cold water tank. Send a 20 mA signal to the three-way control valve so as to let the warm water circulate in the process loop instead of the cold water. Open valve HV4A to let the warm water return to the warm water tank.

Continue recording the temperature measured by the thermocouple probe until it stabilizes to a new, warmer value. Save and transfer the data to a computer for analysis. Write down the temperature of the warm water:

Temperature of the warm water as measured by the thermocouple:

The temperature measured by the thermocouple probe as warm water circulates in the process loop was 32.2°C (90.0°F).



This value is given as an example and depends on the set point programmed in the heating unit and of course on the actual temperature in the tank. Our set point for the warm water was 32.2°C (90°F) while the temperature in the tank was 32.8°C (91°F).

- 13.** Stop drives 1 and 2, let the water drain out of the hoses then, close valve HV4A and open valve HV4B. Send a 4 mA signal to the three-way control valve to make it fully open on L.
- 14.** Turn off the heating/cooling unit, then stop drives 3 and 4. Turn off the pneumatic unit and the electrical unit. Turn off your calibrator or the device used to operate the three-way control valve.

15. Store the equipment adequately, clean up your workspace, and leave the station ready for the next team.

16. From the data you collected or from a printed copy of the obtained graph, determine the time constant τ and the dead time t_d of the thermocouple:

$\tau =$ _____ seconds

$t_d =$ _____ seconds

The time constant obtained in our experiment was $\tau = 15.3$ seconds while the dead time was $t_d = 4.4$ seconds.

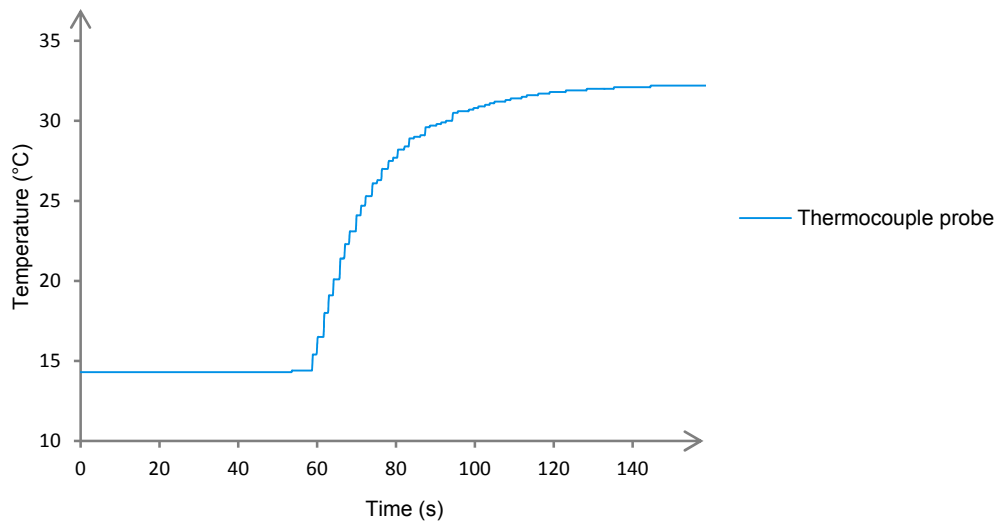

Response of the thermocouple probe to a temperature step change.

17. Compare the time constants (τ and t_d) of the thermocouple to the time constants of the RTD. Which type of temperature probe has the best reaction characteristics?

The results obtained were:

RTD $\tau = 22.2$ s $t_d = 5.5$ s

Thermocouple $\tau = 15.3$ s $t_d = 4.4$ s

Hence, the thermocouple is able to detect temperature changes faster than the RTD (The time constant difference being of almost 7 s).

Why would you use the other type of temperature probe in one of your experiment?

An RTD could be used in any experiment where the speed of measurement is not as crucial as the precision of the measurement. The quoted precision for each type of probes is much in favor of the RTD over the thermocouple (See the Familiarization manual for details).

CONCLUSION

This exercise required the use of a thermocouple probe to measure the temperature of the process fluid. It allowed to gain experience with a temperature element and to determine experimentally the response time of the thermocouple probe. A comparison of the performance of the two types of probes was also made.

The use of temperature measurement devices such as thermocouples and RTDs is crucial in most industrial processes. The exercises of the next unit will include these sensors which will be of great help in the study of heat exchange processes.

REVIEW QUESTIONS

1. What is the name of the effect which relates a generated voltage to a temperature differential in assemblies of two wires made of two different conductors joined together at one end?

The Peltier-Seebeck effect, the thermoelectric effect or simply the Seebeck effect.

2. What is a thermocouple? How does it operate?

A thermocouple is a device that converts a temperature directly into a voltage. The thermocouple consists of a pair of wires made of dissimilar metals or alloys which are joined at one end to form a junction. When the junction is heated, a voltage of a few millivolts is generated across the open ends of the wires.

3. What is a J-type thermocouple made of?

It is a junction of an iron wire and a constantan wire.

4. What is the main disadvantage of using a thermowell to protect the temperature probes?

The thermowell thermally isolates the probes and increases their respective response time.

5. Why is the measurement of the signal generated by a thermocouple not so simple?

When a voltmeter is connected either directly or by means of extension leads across the thermocouple junction, two additional junctions are created which can produce unwanted parasitic voltages. This can result in inaccurate temperature measurements.

Bibliography

Benson, Harris, *University Physics*, New York, John Wiley & Sons, 1996.
ISBN 0-471-00689-0

Çengel, Y. A., and M. A., Boles, *Thermodynamics: An Engineering Approach*, 4th edition, McGraw-Hill College, 2001.
ISBN 0-072-38332-1.

Fahrenheit, D. G., *Fahrenheit's Letters to Leibniz and Boerhaave*, Amsterdam: Radopi, 1983.
ISBN 90-6203-586-8.

Feynman, R. P., R. B. Leighton, and M. Sands, *Feynman Lectures on Physics*, Addison Wesley Longman, 1963.
ISBN 0-201-02010-6-H.

Halpern, A., *Schaum's Outline of Beginning Physics I: Mechanics and Heat*, McGraw-Hill, 1995.
ISBN 0-070-25653-5.

Haynes, W. M., *CRC Handbook of Chemistry and Physics*, 91th edition, CRC Press, 2010.
ISBN 1-439-82077-5.

Incropera, F. P., and D. P. DeWitt, *Fundamentals of Heat and Mass Transfer*, 4th edition, John Wiley and Sons, 1996.
ISBN 0-471-30460-3.

Lipták, B.G., *Instrument Engineers' Handbook: Process Control*, Third Edition, Pennsylvania, Chilton Book Company, 1995,
ISBN 0-8019-8542-1.

Lipták, B.G., *Instrument Engineers' Handbook: Process Measurement and Analysis*, Third Edition, Pennsylvania, Chilton Book Company, 1995,
ISBN 0-8019-8197-2.

Pitts, D., and Sissom, L. E., *Schaum's Outline of Heat Transfer*, 2nd edition, McGraw-Hill, 1998.
ISBN 0-070-50207-2.

The International System of Units (SI), 8th edition