

Electricity and New Energy

Three-Phase Wound-Rotor Induction Machines

Courseware Sample

86367-F0

Order no.: 86367-10

Revision level: 12/2014

By the staff of Festo Didactic

© Festo Didactic Ltée/Ltd, Quebec, Canada 2011, 2014

Internet: www.festo-didactic.com

e-mail: did@de.festo.com

Printed in Canada

All rights reserved

ISBN 978-2-89747-170-5 (Printed version)

ISBN 978-2-89747-171-2 (CD-ROM)

Legal Deposit – Bibliothèque et Archives nationales du Québec, 2014

Legal Deposit – Library and Archives Canada, 2014

The purchaser shall receive a single right of use which is non-exclusive, non-time-limited and limited geographically to use at the purchaser's site/location as follows.

The purchaser shall be entitled to use the work to train his/her staff at the purchaser's site/location and shall also be entitled to use parts of the copyright material as the basis for the production of his/her own training documentation for the training of his/her staff at the purchaser's site/location with acknowledgement of source and to make copies for this purpose. In the case of schools/technical colleges, training centers, and universities, the right of use shall also include use by school and college students and trainees at the purchaser's site/location for teaching purposes.

The right of use shall in all cases exclude the right to publish the copyright material or to make this available for use on intranet, Internet and LMS platforms and databases such as Moodle, which allow access by a wide variety of users, including those outside of the purchaser's site/location.

Entitlement to other rights relating to reproductions, copies, adaptations, translations, microfilming and transfer to and storage and processing in electronic systems, no matter whether in whole or in part, shall require the prior consent of Festo Didactic GmbH & Co. KG.

















Information in this document is subject to change without notice and does not represent a commitment on the part of Festo Didactic. The Festo materials described in this document are furnished under a license agreement or a nondisclosure agreement.

Festo Didactic recognizes product names as trademarks or registered trademarks of their respective holders.

All other trademarks are the property of their respective owners. Other trademarks and trade names may be used in this document to refer to either the entity claiming the marks and names or their products. Festo Didactic disclaims any proprietary interest in trademarks and trade names other than its own.

Safety and Common Symbols

The following safety and common symbols may be used in this manual and on the equipment:

Symbol	Description
	DANGER indicates a hazard with a high level of risk which, if not avoided, will result in death or serious injury.
	WARNING indicates a hazard with a medium level of risk which, if not avoided, could result in death or serious injury.
	CAUTION indicates a hazard with a low level of risk which, if not avoided, could result in minor or moderate injury.
	CAUTION used without the <i>Caution, risk of danger</i> sign  , indicates a hazard with a potentially hazardous situation which, if not avoided, may result in property damage.
	Caution, risk of electric shock
	Caution, hot surface
	Caution, risk of danger
	Caution, lifting hazard
	Caution, hand entanglement hazard
	Notice, non-ionizing radiation
	Direct current
	Alternating current
	Both direct and alternating current
	Three-phase alternating current
	Earth (ground) terminal

Safety and Common Symbols









Symbol	Description
	Protective conductor terminal
	Frame or chassis terminal
	Equipotentiality
	On (supply)
	Off (supply)
	Equipment protected throughout by double insulation or reinforced insulation
	In position of a bi-stable push control
	Out position of a bi-stable push control

Table of Contents

Preface	VII
About This Manual	IX
To the Instructor	XI
Introduction Three-Phase Wound-Rotor Induction Machines	1
DISCUSSION OF FUNDAMENTALS	1
Introduction to three-phase wound-rotor induction machines.....	1
Exercise 1 Three-Phase Wound-Rotor Induction Machine with a Short-Circuited Rotor	5
DISCUSSION	5
Three-phase wound-rotor induction machine with a short-circuited rotor windings	5
PROCEDURE.....	6
Set up and connections	6
Three-phase wound-rotor induction machine operation with a short-circuited rotors.....	9
Exercise 2 Three-Phase Wound-Rotor Induction Machine with Rotor Resistance.....	21
DISCUSSION	21
Three-phase wound-rotor induction machine starting current and torque versus the rotor resistance	21
Three-phase wound-rotor induction machine starting current	22
Three-phase wound-rotor induction machine starting torque ...	23
Varying the speed of a three-phase wound-rotor induction machine through the rotor resistance	24
PROCEDURE.....	27
Set up and connections	27
Effect of the rotor resistance on the operation of a three-phase wound-rotor induction machine.....	30
Appendix A Equipment Utilization Chart	39
Appendix B Glossary of New Terms.....	41
Appendix C Impedance Table for the Load Modules.....	43
Appendix D Circuit Diagram Symbols.....	45

Table of Contents

Appendix E Pulley Removal and Installation Procedure.....	51
Removing the pulley from a rotating machine	51
Installing a pulley on a machine.....	52
 Index of New Terms	 55
Bibliography	57

Preface

The production of energy using renewable natural resources such as wind, sunlight, rain, tides, geothermal heat, etc., has gained much importance in recent years as it is an effective means of reducing greenhouse gas (GHG) emissions. The need for innovative technologies to make the grid smarter has recently emerged as a major trend, as the increase in electrical power demand observed worldwide makes it harder for the actual grid in many countries to keep up with demand. Furthermore, electric vehicles (from bicycles to cars) are developed and marketed with more and more success in many countries all over the world.

To answer the increasingly diversified needs for training in the wide field of electrical energy, the Electric Power Technology Training Program was developed as a modular study program for technical institutes, colleges, and universities. The program is shown below as a flow chart, with each box in the flow chart representing a course.

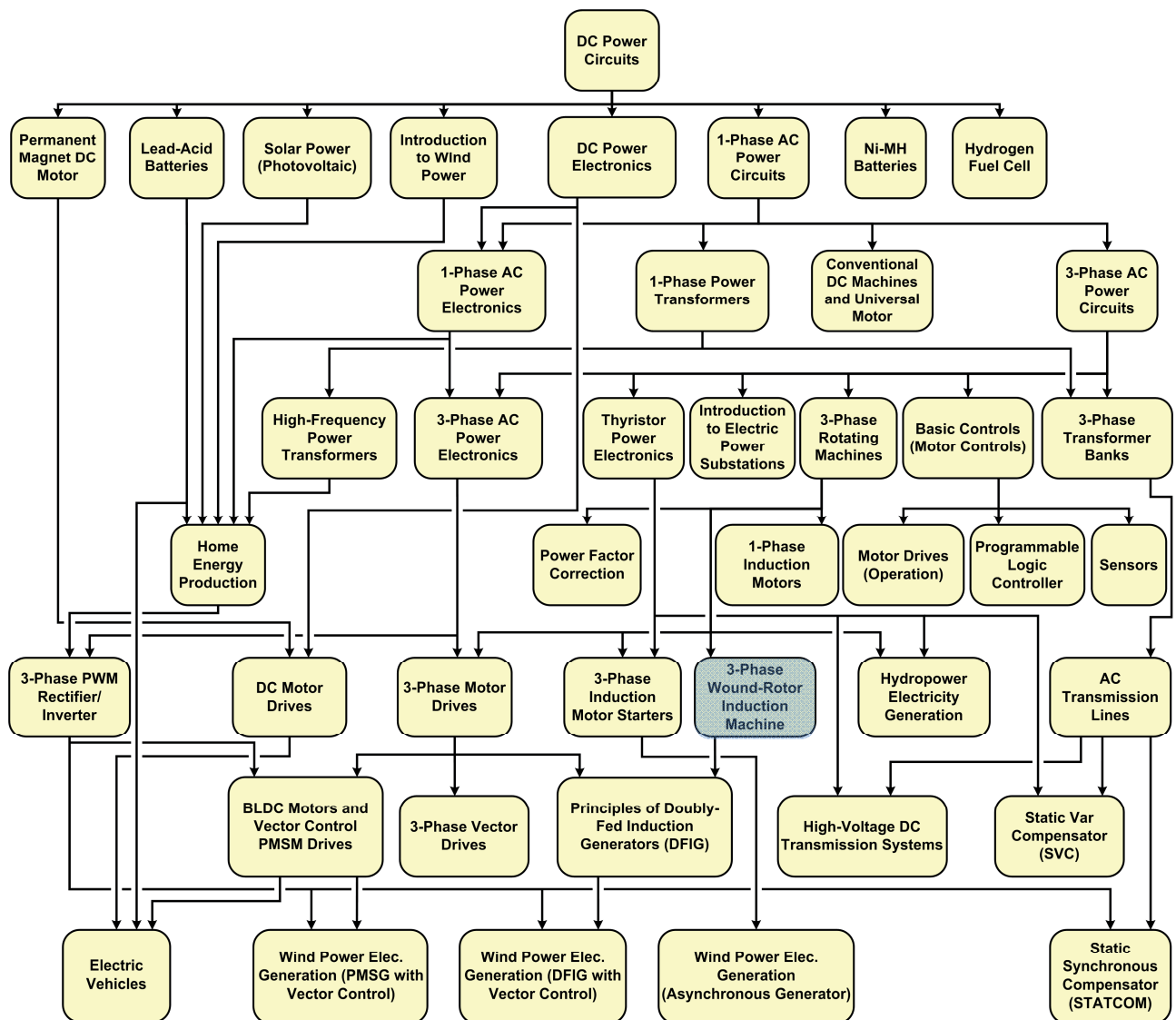

The Electric Power Technology Training Program.

Preface

The program starts with a variety of courses providing in-depth coverage of basic topics related to the field of electrical energy such as ac and dc power circuits, power transformers, rotating machines, ac power transmission lines, and power electronics. The program then builds on the knowledge gained by the student through these basic courses to provide training in more advanced subjects such as home energy production from renewable resources (wind and sunlight), large-scale electricity production from hydropower, large-scale electricity production from wind power (doubly-fed induction generator [DFIG], synchronous generator, and asynchronous generator technologies), smart-grid technologies (SVC, STATCOM, HVDC transmission, etc.), storage of electrical energy in batteries, and drive systems for small electric vehicles and cars.

Do you have suggestions or criticism regarding this manual?

If so, send us an e-mail at did@de.festo.com.

The authors and Festo Didactic look forward to your comments.

About This Manual

The primary difference between three-phase wound-rotor induction machines and three-phase squirrel-cage induction machines is the design of the machine rotor. The rotor of three-phase squirrel-cage induction machines is made of conducting bars short-circuited by rings at both ends, while the rotor of three-phase wound-rotor induction machines consists of wire windings similar to the machine stator windings. These rotor windings are accessible through slip rings and brushes, allowing the connection of electrical components to the machine rotor.

Three-phase wound-rotor induction machines offer a number of advantages over other types of induction machines, most notably the ability to produce high starting torques at lower starting currents. Large three-phase wound-rotor induction machines are also easier to assemble than comparatively sized three-phase squirrel-cage induction machines. Due to these advantages, three-phase wound-rotor induction machines are commonly used in industry for any application requiring a large rotating machine (0.75 MW, or 1000 hp, and more). In such cases, the ability to produce a high starting torque with a reasonable starting current is crucial.

Another particularity of three-phase wound-rotor induction machines is the possibility to adjust the machine operating speed by controlling the rotor currents. Due to this feature, three-phase wound-rotor induction machines were traditionally used in applications requiring a rotating machine to run over a wide range of speeds. Today, however, the ability to adjust the speed of three-phase wound-rotor induction machines is used less frequently because the same results can be achieved more efficiently by controlling the speed of three-phase squirrel-cage induction machines using variable-frequency motor drives.

This manual, Three-Phase Wound-Rotor Induction Machines, introduces the student to the operation of three-phase wound-rotor induction machines. The student then learns the effects which varying the rotor resistor has on the starting current and torque of the machine. Through this process, the student also learns how to vary the rotation speed of a wound-rotor induction machine.

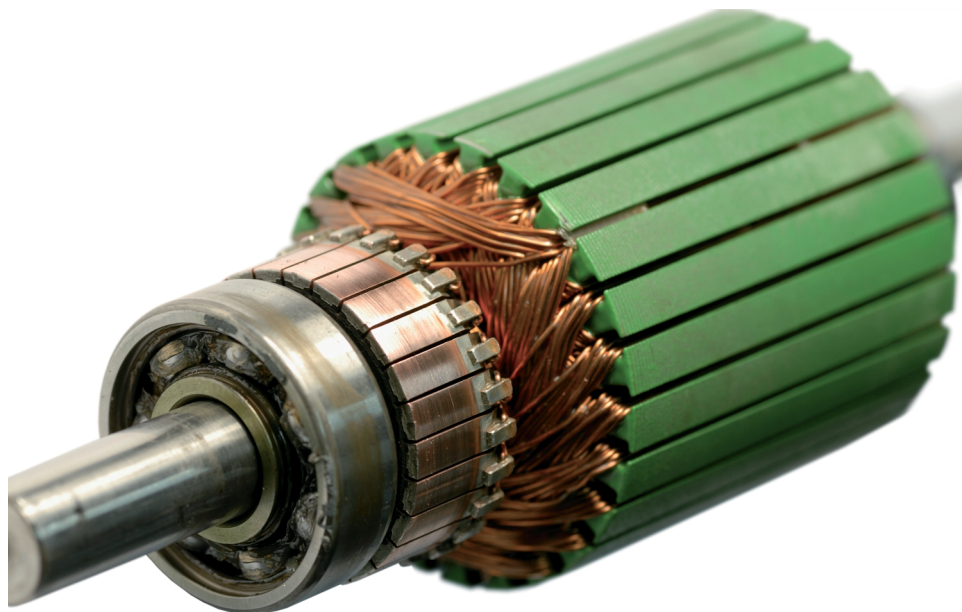

Typical wound-rotor found in three-phase wound-rotor induction machines.

About This Manual

Safety considerations

Safety symbols that may be used in this manual and on the equipment are listed in the Safety Symbols table at the beginning of the manual.

Safety procedures related to the tasks that you will be asked to perform are indicated in each exercise.

Make sure that you are wearing appropriate protective equipment when performing the tasks. You should never perform a task if you have any reason to think that a manipulation could be dangerous for you or your teammates.

Prerequisite

As a prerequisite to this course, you should have read the manuals titled *DC Power Circuits*, p.n. 86350, *Single-Phase AC Power Circuits*, p.n. 86358, *Three-Phase AC Power Circuits*, p.n. 86360, and *Three-Phase Rotating Machines*, p.n. 86364.

Systems of units

Units are expressed using the International System of Units (SI) followed by the units expressed in the U.S. customary system of units (between parentheses).

To the Instructor

You will find in this Instructor Guide all the elements included in the Student Manual together with the answers to all questions, results of measurements, graphs, explanations, suggestions, and, in some cases, instructions to help you guide the students through their learning process. All the information that applies to you is placed between markers and appears in red.

Accuracy of measurements

The numerical results of the hands-on exercises may differ from one student to another. For this reason, the results and answers given in this manual should be considered as a guide. Students who correctly performed the exercises should expect to demonstrate the principles involved and make observations and measurements similar to those given as answers.

Equipment installation

In order for students to be able to perform the exercises in the Student Manual, the Electric Power Technology Training Equipment must have been properly installed, according to the instructions given in the user guide Electric Power Technology Training Equipment, part number 38486-E.

Sample Exercise
Extracted from
the Student Manual
and the Instructor Guide

Three-Phase Wound-Rotor Induction Machine with Rotor Resistance

EXERCISE OBJECTIVE

When you have completed this exercise, you will know the effects of varying the rotor resistance of a three-phase wound-rotor induction machine on the machine starting current and torque, as well as on the machine rotation speed and efficiency.

DISCUSSION OUTLINE

The Discussion of this exercise covers the following points:

- Three-phase wound-rotor induction machine starting current and torque versus the rotor resistance
- Varying the speed of a three-phase wound-rotor induction machine through the rotor resistance

DISCUSSION

Three-phase wound-rotor induction machine starting current and torque versus the rotor resistance

Three-phase wound-rotor induction machines have an important advantage over three-phase squirrel-cage induction machines during start-up: it is possible to reduce the starting current while increasing the starting torque. The ability of wound-rotor induction machines to reduce the starting current is crucial for large-size induction machines (0.75 MW, or 1000 hp, and more) because during this period, the current requirements of large squirrel-cage induction machines can be as high as four times the machine nominal current. Such high current requirements put a great strain on the ac power network and make large squirrel-cage induction machines impractical or even impossible to start.

Large-size induction machines are also required to produce high starting torques as they are generally used to drive high-inertia loads (e.g., large pumps, cranes, grinders). In such cases, the ability of three-phase wound-rotor induction machines to increase the machine starting torque is beneficial because it reduces the amount of time required for the machine to reach the nominal speed and shortens the machine start-up time (and thus, the amount of time during which the current drawn by the machine is many times the nominal current).

The following two sections explain in more detail the ability of three-phase wound-rotor induction machines to reduce the machine current and increase the machine torque during start-up.

Three-phase wound-rotor induction machine starting current

The starting current of a three-phase wound-rotor induction machine can be lowered by increasing the machine rotor resistance. The relationship between the amount of current drawn by a three-phase wound-rotor induction machine as a function of the machine speed for different rotor resistance values is shown in Figure 4.

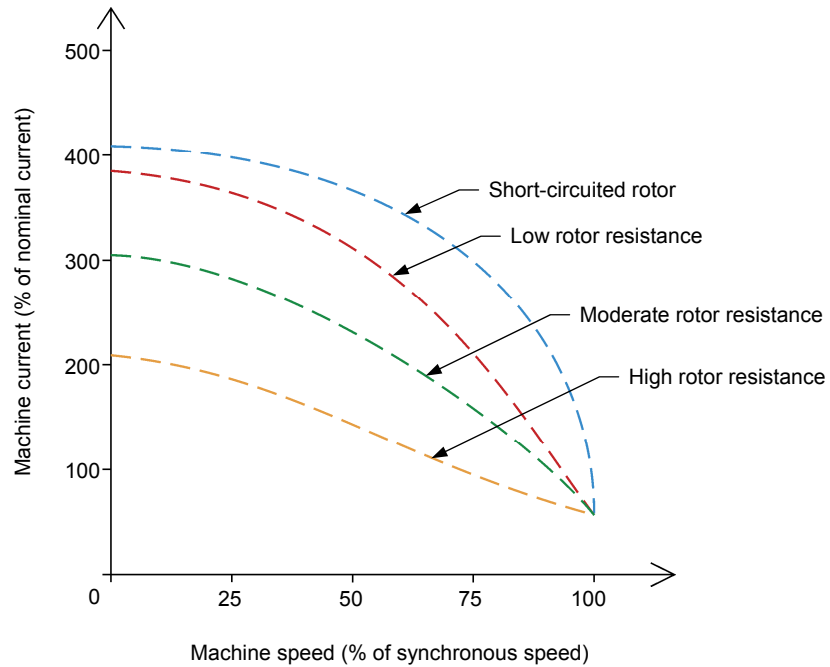

Figure 4. Three-phase wound-rotor induction machine starting current as a function of the machine speed for different rotor resistance values.

As Figure 4 shows, the higher the rotor resistance of a three-phase wound-rotor induction machine, the lower the machine starting current. For instance, passing from a short-circuited rotor condition to a high rotor resistance condition reduces the machine starting current from about 400% of the machine nominal current to about 200% of the machine nominal current. As large-size machines require a large amount of current during start-up, such a gain can make an enormous difference. Figure 4 also shows that, as the machine nears the synchronous speed, the effect of the machine rotor resistance on the machine current becomes less and less important until, at the synchronous speed, the machine current is the same for any rotor resistance.

Three-phase wound-rotor induction machine starting torque

The starting torque of a three-phase wound-rotor induction machine, like its starting current, can be adjusted by changing the rotor resistance. Increasing the rotor resistance of a three-phase wound-rotor induction machine has the effect of shifting toward the left the breakdown torque region on the torque-versus-speed curve. The relationship between the torque and speed of a three-phase wound-rotor induction machine for different rotor resistance values is shown in Figure 5.

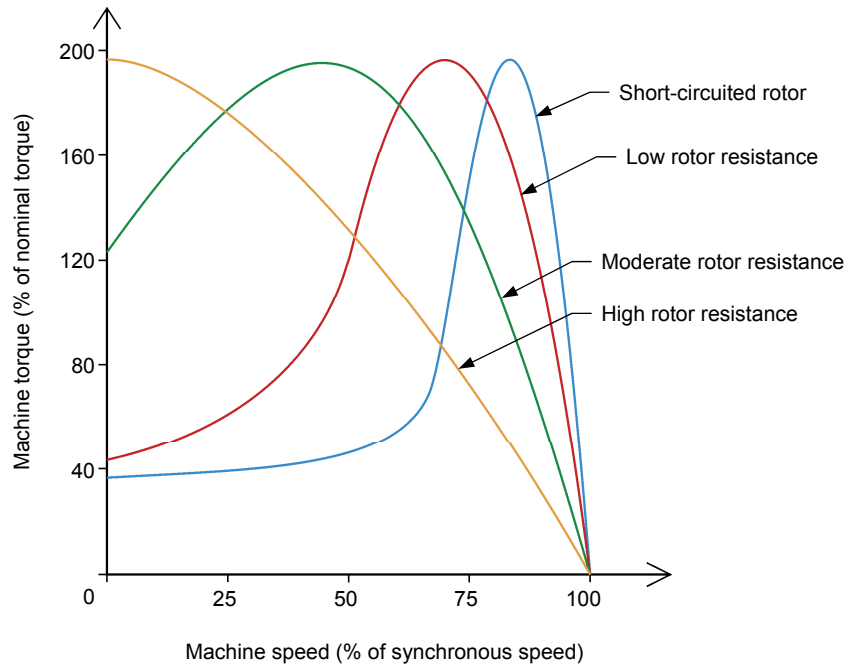

Figure 5. Three-phase wound-rotor induction machine torque-versus-speed curves for different rotor resistance values.

As Figure 5 shows, the higher the rotor resistance of the three-phase wound-rotor induction machine (up to a certain value), the higher the machine starting torque. However, as the machine speed increases, a high rotor resistance causes the machine torque to decrease more rapidly than when lower rotor resistance values are used. For this reason, after the machine initial start-up, the rotor resistance is usually progressively lowered, or simply short-circuited, in order to reduce the rotor resistance to a minimum and optimize the machine torque.

Figure 6 shows on the same graph both the current-versus-speed and torque-versus-speed curves of a three-phase wound-rotor induction machine for different rotor resistance values. As you can see, when the machine rotor resistance is high, the starting current is minimal and the starting torque is maximal. This is perfectly adapted to applications where large induction machines are started under heavy mechanical loads.

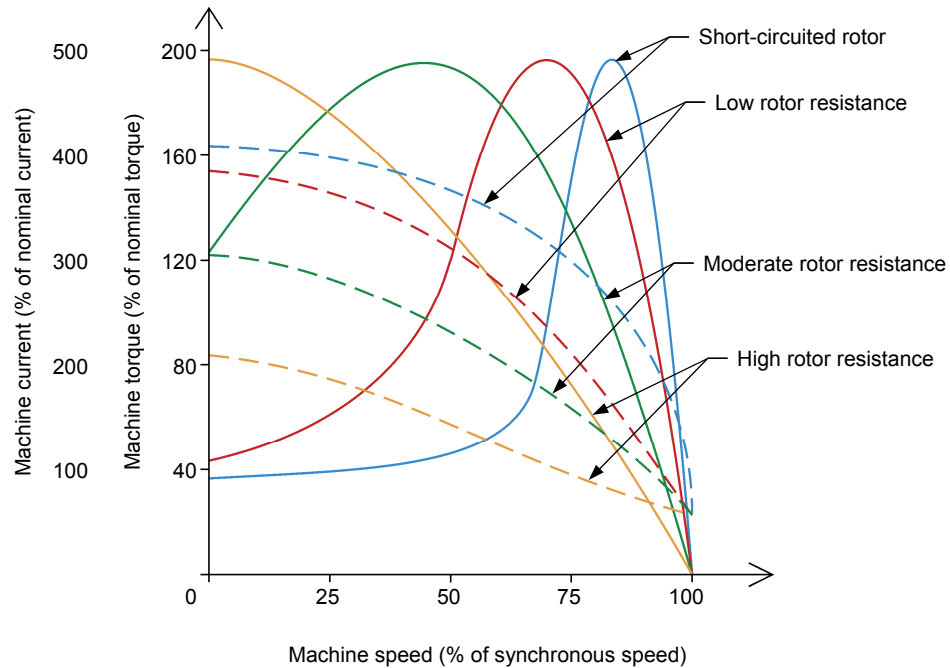

Figure 6. Three-phase wound-rotor induction machine current-versus-speed and torque-versus-speed curves for different rotor resistance values.

Varying the speed of a three-phase wound-rotor induction machine through the rotor resistance

Another advantage three-phase wound-rotor induction machines have over three-phase squirrel-cage induction machines is the ability to adjust the machine speed. Traditionally, this ability was used in applications requiring the machine to run over a wide range of speeds. Nowadays, however, the ability to adjust the speed of three-phase wound-rotor induction machines is less and less used as the same results can be achieved more efficiently by controlling three-phase squirrel-cage induction machines using variable-frequency motor drives.

It is possible to adjust the speed of three-phase wound-rotor induction machines by varying the rotor resistance. For any given torque (within the normal operating range of the machine), the higher the rotor resistance, the lower the machine rotation speed. This relationship is illustrated in Figure 7. In this example, a three-phase wound-rotor induction machine is coupled to a constant-torque brake that produces a constant opposing torque. As you can see, for a given machine torque during motor operation, the machine speed decreases as the machine rotor resistance increases.

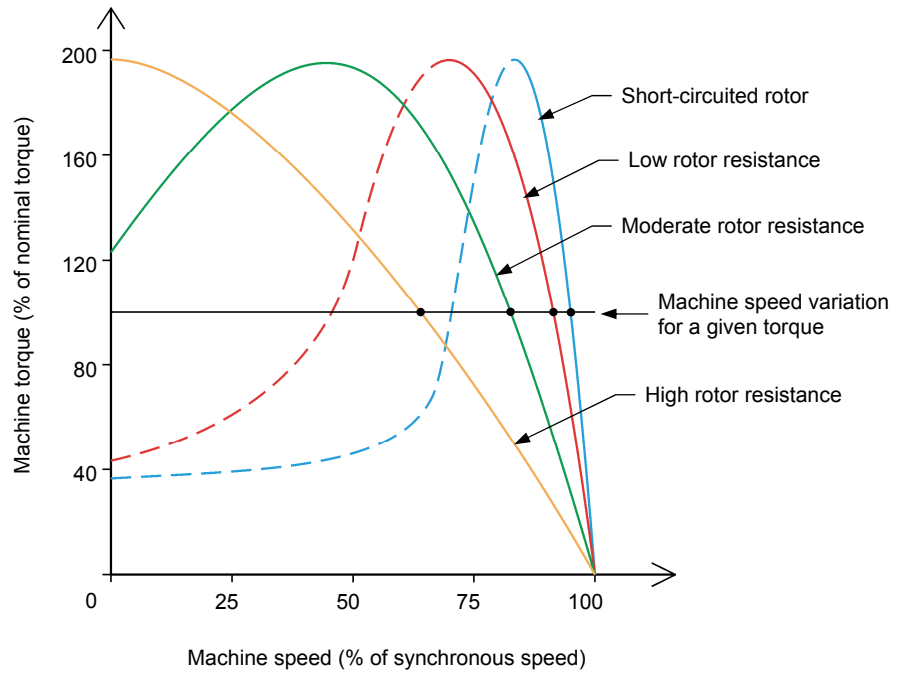

Figure 7. Three-phase wound-rotor induction machine speed variation for a given torque for different rotor resistance values.

However, varying the three-phase wound-rotor induction machine speed in such a way has drawbacks. The most important is that it reduces the machine efficiency. This is due to the fact that adding resistance to the machine rotor increases the active power losses (I^2R) and thus lowers the machine efficiency.

In addition, the higher the rotor resistance of a three-phase wound-rotor induction machine, the greater the variation in the rotation speed as the torque varies. This relationship is illustrated in Figure 8. As the figure shows, for a given torque variation, the resulting machine speed variation is much more important when the machine rotor resistance is high than when the machine rotor is short-circuited. This means that three-phase wound-rotor induction machines having a high rotor resistance are more susceptible to speed variations as the load torque changes.

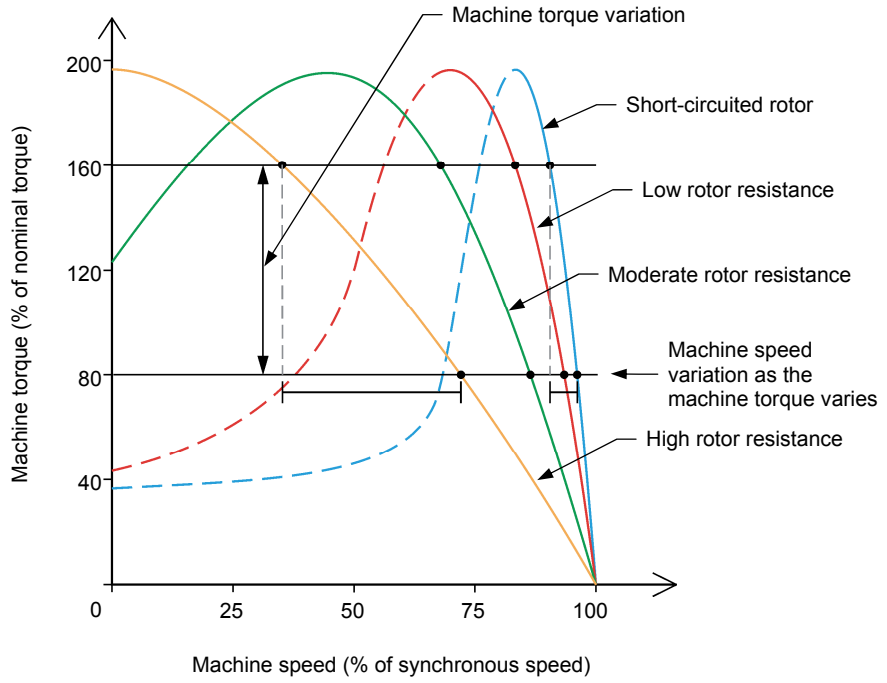

Figure 8. Three-phase wound-rotor induction machine speed variation as the machine torque varies for different rotor resistance values.

PROCEDURE OUTLINE

The Procedure is divided into the following sections:

- Set up and connections
- Effect of the rotor resistance on the operation of a three-phase wound-rotor induction machine

PROCEDURE

WARNING



High voltages are present in this laboratory exercise. Do not make or modify any banana jack connections with the power on unless otherwise specified.

Set up and connections

In this section, you will set up a circuit containing a three-phase wound-rotor induction machine coupled to a prime mover/brake. You will then set the measuring equipment required to study the three-phase wound-rotor induction machine operation when the rotor windings are interconnected through resistors.

1. Refer to the Equipment Utilization Chart in Appendix A to obtain the list of equipment required to perform this exercise.

Make sure that a 32 teeth pulley is installed on the shaft of the [Three-Phase Wound-Rotor Induction Machine](#). If not, ask your instructor to install the pulley required on the shaft of the machine.



Appendix E shows how to replace the pulley installed on the shaft of a supplied machine.

Install the required equipment in the [Workstation](#).



Make sure you use the same [Four-Quadrant Dynamometer/Power Supply](#) module as in Exercise 1 of this manual by confirming that the module's serial number is the same as the serial number you recorded in the first step of Exercise 1.

Mechanically couple the [Three-Phase Wound-Rotor Induction Machine](#) to the [Four-Quadrant Dynamometer/Power Supply](#) using the timing belt (type 341L) supplied with the 32 teeth pulley.

2. Make sure that the ac and dc power switches on the [Power Supply](#) are set to the **O** (off) position, then connect the [Power Supply](#) to a three-phase ac power outlet.

Make sure that the main power switch on the [Four-Quadrant Dynamometer/Power Supply](#) is set to the **O** (off) position, then connect its *Power Input* to an ac power wall outlet.

Connect the *Power Input* of the [Data Acquisition and Control Interface](#) to a 24 V ac power supply.

3. Connect the USB port of the **Data Acquisition and Control Interface** to a USB port of the host computer.

Connect the USB port of the **Four-Quadrant Dynamometer/Power Supply** to a USB port of the host computer.

4. Connect the equipment as shown in Figure 9.

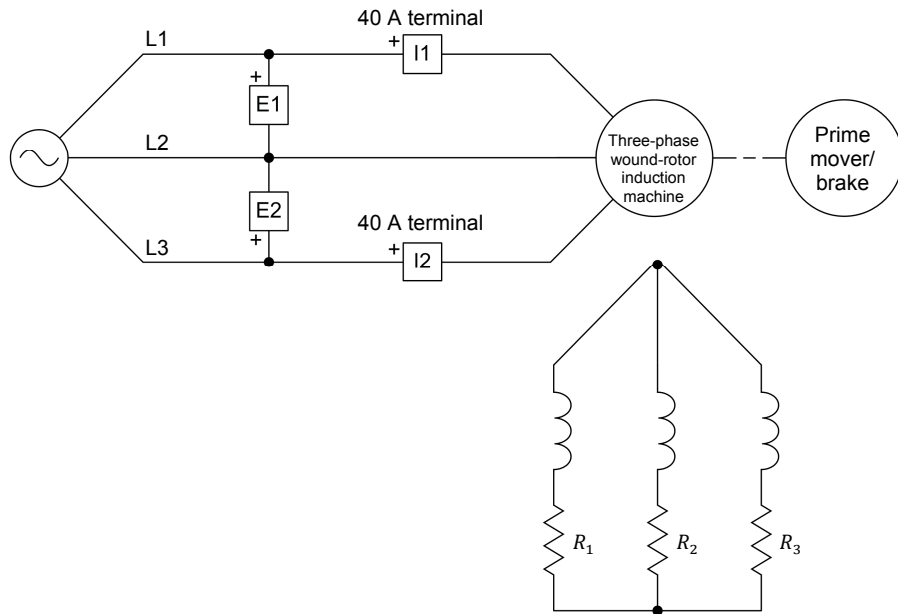

Local ac power network		Rotor resistance
Voltage (V)	Frequency (Hz)	R_1, R_2, R_3 (Ω)
120	60	171
220	50	629
240	50	686
220	60	629

Figure 9. Three-phase wound-rotor induction machine with rotor resistance coupled to a prime mover/brake.

5. Make the necessary switch settings on the **Resistive Load** module in order to obtain the rotor resistance value required.



The values of certain components used in the circuits of this manual depend on your local ac power network voltage and frequency. Whenever necessary, a table below the circuit diagram indicates the value of each component for ac power network voltages of 120 V, 220 V, and 240 V, and for ac power network frequencies of 50 Hz and 60 Hz. Make sure to use the component values corresponding to your local ac power network voltage and frequency.



Appendix C lists the switch settings required on the **Resistive Load** in order to obtain various resistance values.

6. Turn the **Four-Quadrant Dynamometer/Power Supply** on, then set the **Operating Mode** switch to **Dynamometer**. This setting allows the **Four-Quadrant Dynamometer/Power Supply** to operate as a prime mover, a brake, or both, depending on the selected function.
7. Turn the host computer on, then start the **LVDAC-EMS** software.

In the **LVDAC-EMS Start-Up** window, make sure that the **Data Acquisition and Control Interface** and the **Four-Quadrant Dynamometer/Power Supply** are detected. Make sure that the **Computer-Based Instrumentation** function for the **Data Acquisition and Control Interface** is available. Select the network voltage and frequency of your local ac power network, then click the **OK** button to close the **LVDAC-EMS Start-Up** window.

8. In **LVDAC-EMS**, set the **Range** setting of current inputs **I1** and **I2** to **High**.
9. In **LVDAC-EMS**, open the **Four-Quadrant Dynamometer/Power Supply** window, then make the following settings:
 - Set the **Function** parameter to **Speed Sweep**.
 - Set the **Start Speed** parameter to 100 r/min above the synchronous speed of the three-phase wound-rotor induction machine.



The synchronous speed of the **Three-Phase Wound-Rotor Induction Machine** is 1500 r/min at a local ac power network frequency of 50 Hz and 1800 r/min at a local ac power network frequency of 60 Hz.

- Set the **Finish Speed** parameter to 200 r/min below the synchronous speed of the three-phase induction motor.
 - Set the **Number of Steps** parameter to 15 steps.
 - Set the **Step Duration** parameter to 7 s.
 - Set the **Record Data to Table** parameter to **Yes**.
 - Set the **Pulley Ratio** parameter to 24:32.
10. In **LVDAC-EMS**, start the **Metering** application. Make the required settings in order to measure the rms values (ac) of the three-phase wound-rotor induction machine line current I_{Line} (input **I1**). Set two other meters to measure the machine active power P and reactive power Q using the two-wattmeter method (meter function **PQS1 + PQS2**). Finally, set a meter to measure the machine power factor PF from inputs **E1**, **I1**, **E2**, and **I2**.

11. In LVDAC-EMS, open the **Data Table** window.

Set the **Data Table** to record the three-phase wound-rotor induction machine speed n , torque T , and mechanical power P_M indicated in the **Four-Quadrant Dynamometer/Power Supply** window.

Also, set the **Data Table** to record the three-phase wound-rotor induction machine line current I_{Line} (input $I1$), active power P , reactive power Q , and power factor PF indicated in the **Metering** application.

Effect of the rotor resistance on the operation of a three-phase wound-rotor induction machine

In this section, you will make the three-phase wound-rotor induction machine speed decrease by step from 100 r/min above the machine synchronous speed to 0 r/min, recording at each step in the Data Table the machine speed, torque, mechanical power, line current, active power, reactive power, and power factor. You will calculate the machine efficiency using the recorded machine mechanical power and active power values. On the same graph, you will plot the torque versus speed curve when the rotor is short-circuited (using the results you obtained in the previous exercise), as well as when resistance is added to the rotor, and interpret the results. Finally, you will plot on the same graph the efficiency versus mechanical power curve when the rotor is short-circuited (using the results you obtained in the previous exercise), as well as when resistance is added to the rotor, and interpret the results.

12. On the **Power Supply**, turn the three-phase ac power source on.



*The Three-Phase Wound-Rotor Induction Machine is fitted with an overvoltage protection circuit preventing the rotor voltage from reaching values that could damage the machine rotor windings. If the overvoltage protection trips when performing the manipulation above, turn the three-phase ac power source off, wait a few seconds, and turn the three-phase ac power on while pressing and holding the **Protection Override** push-button on the **Three-Phase Wound-Rotor Induction Machine**.*

Before starting the prime mover/brake (i.e., before starting the **Speed Sweep** function), make sure that the **Three-Phase Wound-Rotor Induction Machine** is rotating in the clockwise direction. If so, proceed directly to the next step. Otherwise, turn the three-phase ac power source off, invert the connections at two of the three phase terminals of the machine stator windings, then repeat this step from the beginning.

13. In the **Four-Quadrant Dynamometer/Power Supply** window, start the **Speed Sweep** function.

14. Wait for the **Speed Sweep** function to complete its sweep of the specified speed interval. Then, in the **Four-Quadrant Dynamometer/Power Supply** window, make the following settings:
 - Set the **Start Speed** parameter to 40 r/min below the speed value at which you set the **Finish Speed** parameter in step 9.
 - Set the **Finish Speed** parameter to 0 r/min.
 - Set the **Number of Steps** parameter to a value between 13 and 16 steps.
 - Make sure that the **Step Duration** parameter is set to 7 s.
 - Make sure that the **Record Data to Table** parameter is set to **Yes**.
 - Make sure that the **Pulley Ratio** parameter is set to 24:32.

15. In the **Four-Quadrant Dynamometer/Power Supply** window, start the **Speed Sweep** function. Wait for the **Speed Sweep** function to complete its sweep of the specified speed interval.



*If the overvoltage protection trips at the end of the speed sweep performed above (i.e., when the speed of the three-phase wound-rotor induction machine approaches 0 r/min), stop the **Speed Sweep** function, turn the three-phase ac source power source off, delete the data recorded to the **Data Table** during this speed sweep, turn the three-phase ac power source on, and start the **Speed Sweep** function again. This time, however, press and hold the **Protection Override** push-button on the **Three-Phase Wound-Rotor Induction Machine** as soon as the speed decreases below 200 r/min. Release the push-button once the speed sweep is completed.*

16. When all data has been recorded, turn the three-phase ac power source in the **Power Supply** off.

17. In the **Data Table** window, save the recorded data, then export it to a spreadsheet application.



The machine torque recorded when the machine speed is equal to 0 r/min is slightly underestimated due to the way friction compensation is implemented in the Four-Quadrant Dynamometer/Power Supply.

In the spreadsheet application, add a new parameter to the results: the three-phase wound-rotor induction machine efficiency η . To calculate the machine efficiency η , use the following equations:

- When the machine mechanical power P_M is of positive polarity (i.e., when the machine operates as a motor), divide each machine mechanical power value P_M by the corresponding machine active power value P , then multiply the result by 100 to express the efficiency η as a percentage.
- When the machine mechanical power P_M is of negative polarity (i.e., when the machine operates as a generator), divide each machine active power value P by the corresponding machine mechanical power value P_M , then multiply the result by 100.



Do not calculate the machine efficiency η when the machine mechanical power P_M is lower than about 50 W (positive or negative).

Also, in the spreadsheet application, make sure that all power factor values are of positive polarity by inverting the polarity of all negative power factor values.

The results obtained are presented below.

Three-phase wound-rotor induction machine speed n , torque T , mechanical power P_M , line current I_{Line} , active power P , reactive power Q , power factor PF , and efficiency η when resistance is added to the rotor.

Speed n (r/min)	Torque T (N·m) [lbf·in]	Mechanical power P_M (W)	Line current I_{Line} (A)	Active power P (W)	Reactive power Q (var)	Power factor PF	Efficiency η (%)
1900	-0.53 (-4.72)	-106.0	1.05	-48.57	367.6	0.13	45.82
1882	-0.44 (-3.90)	-86.90	1.03	-30.32	363.1	0.08	34.89
1862	-0.34 (-3.00)	-66.14	1.02	-13.49	358.4	0.04	20.40
1841	-0.25 (-2.22)	-48.32	1.01	2.06	355.7	0.01	-
1822	-0.16 (-1.42)	-30.60	1.00	21.84	351.8	0.06	-
1802	-0.06 (-0.55)	-11.73	0.99	37.58	346.1	0.11	-
1781	0.03 (0.30)	6.40	0.99	55.21	338.6	0.16	-
1761	0.12 (1.02)	21.22	0.99	71.59	335.7	0.21	-
1742	0.20 (1.80)	37.02	0.99	88.29	336.5	0.25	-
1721	0.29 (2.59)	52.79	0.99	105.7	334.5	0.30	49.94
1701	0.38 (3.38)	68.09	1.00	123.4	331.1	0.35	55.18
1681	0.46 (4.11)	81.59	1.01	138.6	328.1	0.39	58.87
1661	0.55 (4.85)	95.25	1.03	154.1	327.8	0.43	61.81
1641	0.63 (5.53)	107.5	1.04	172.0	327.4	0.47	62.50
1622	0.71 (6.26)	120.0	1.06	188.8	323.9	0.50	63.56
1601	0.78 (6.89)	130.5	1.07	204.0	321.1	0.54	63.97
1561	0.93 (8.23)	152.0	1.12	236.4	321.1	0.59	64.30
1459	1.28 (11.31)	195.3	1.26	315.4	319.7	0.70	61.92
1355	1.60 (14.17)	227.3	1.42	388.9	325.2	0.77	58.45
1250	1.90 (16.81)	248.6	1.60	461.4	336.1	0.81	53.88
1145	2.16 (19.10)	258.9	1.78	530.1	351.4	0.83	48.84
1042	2.37 (20.98)	258.6	1.95	590.6	368.1	0.85	43.79
938	2.59 (22.92)	254.3	2.11	644.5	381.8	0.86	39.46
833	2.80 (24.79)	244.4	2.27	702.0	400.5	0.87	34.81
730	2.97 (26.26)	226.7	2.42	756.2	423.4	0.87	29.98
625	3.12 (27.57)	203.8	2.58	802.8	446.6	0.87	25.39
521	3.24 (28.65)	176.5	2.72	848.6	471.1	0.87	20.80
416	3.33 (29.44)	145.0	2.85	885.7	490.4	0.88	16.37
313	3.43 (30.31)	112.2	2.98	927.3	515.3	0.87	12.10
209	3.51 (31.04)	76.57	3.10	962.3	539.0	0.87	7.96
104	3.58 (31.66)	39.05	3.21	988.8	558.1	0.87	3.95
0	3.45 (30.54)	0.00	3.20	1022.0	575.1	0.87	0.00

18. Plot on the same graph curves of the three-phase wound-rotor induction machine torque T as a function of the machine speed n when the rotor is short-circuited, as well as when resistance is added to the rotor. Use the results you recorded in the previous exercise and in this exercise to do so.

The resulting graphs are shown below.

When the machine torque T is expressed in N·m:

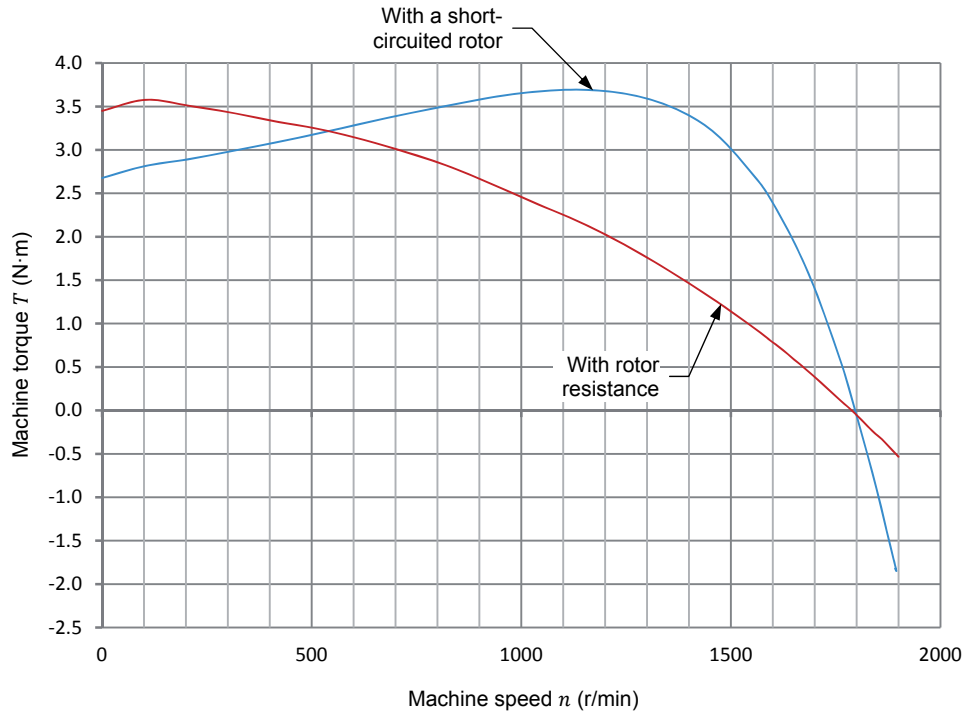

Three-phase wound-rotor induction machine torque T (expressed in N·m) as a function of the machine speed n when the rotor is short-circuited, as well as when resistance is added to the rotor.

When the machine torque T is expressed in lbf-in:

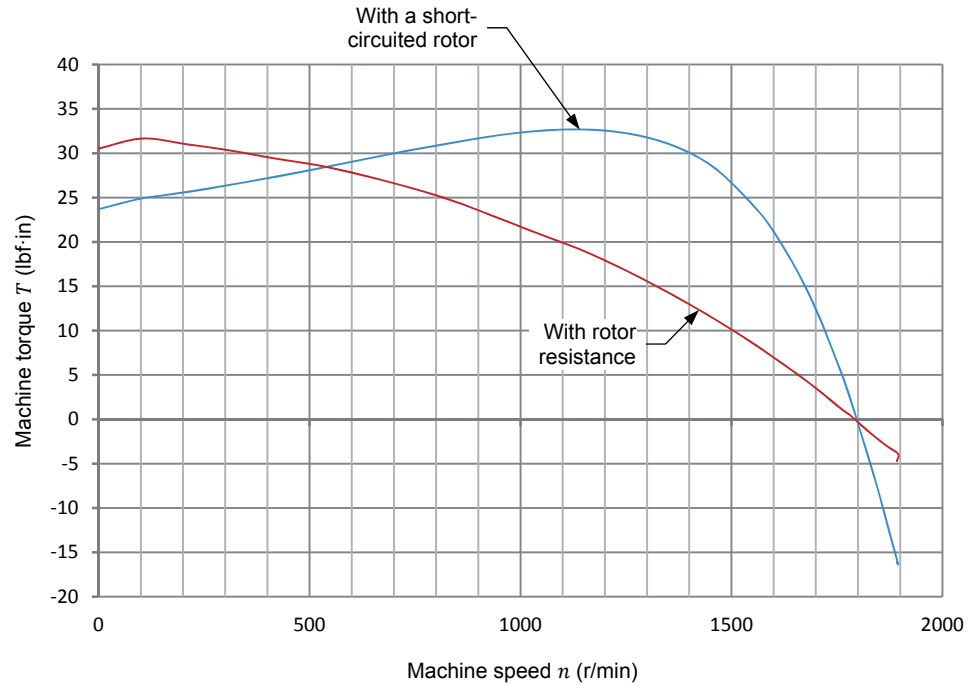

Three-phase wound-rotor induction machine torque T (expressed in lbf-in) as a function of the machine speed n when the rotor is short-circuited, as well as when resistance is added to the rotor.

Observe the graph you plotted. How does adding resistance to the rotor affect the starting torque of a three-phase wound-rotor induction machine?

Adding resistance to the rotor of a three-phase wound-rotor induction machine increases the starting torque.

Compare the starting current (line current at speed of 0 r/min) of the three-phase wound-rotor induction machine with a short-circuited rotor (recorded in the previous exercise) with the starting current of the three-phase wound-rotor induction machine with rotor resistance (recorded earlier in this exercise). How does adding resistance to the rotor affect the starting current of a three-phase wound-rotor induction machine?

Adding resistance to the rotor of a three-phase wound-rotor induction machine decreases the starting current.

Does this confirm that a three-phase wound-rotor induction machine with added resistance at the rotor is perfectly adapted to applications where the machine has to start under heavy mechanical loads?

Yes No

Yes

19. Observe the graph you plotted in the previous step. What is the effect, if any, of adding resistance to the rotor of a three-phase wound-rotor induction machine on the machine torque T versus speed n curve?

Adding resistance to the rotor of a three-phase wound-rotor induction machine causes the machine torque T versus speed n curve to become much less steep, in both motor and generator operation. This means that, when the rotor resistance is increased, the machine torque T increases much less rapidly as the machine slip increases.

Do your results confirm that increasing the resistance at the rotor of a three-phase wound-rotor induction machine changes the machine speed n for a given machine torque T ?

Yes No

Yes

20. Plot on the same graph curves of the three-phase wound-rotor induction machine efficiency η as a function of the machine mechanical power P_M with a short-circuited rotor, as well as with rotor resistance, when the machine operates as a motor ($P_M \geq 50$ W). Use the results you recorded in the previous exercise and in this exercise to do so. Do not plot on the graph the points recorded after the motor mechanical power P_M started to decrease after having reached a maximal value.

The resulting graph is shown below.

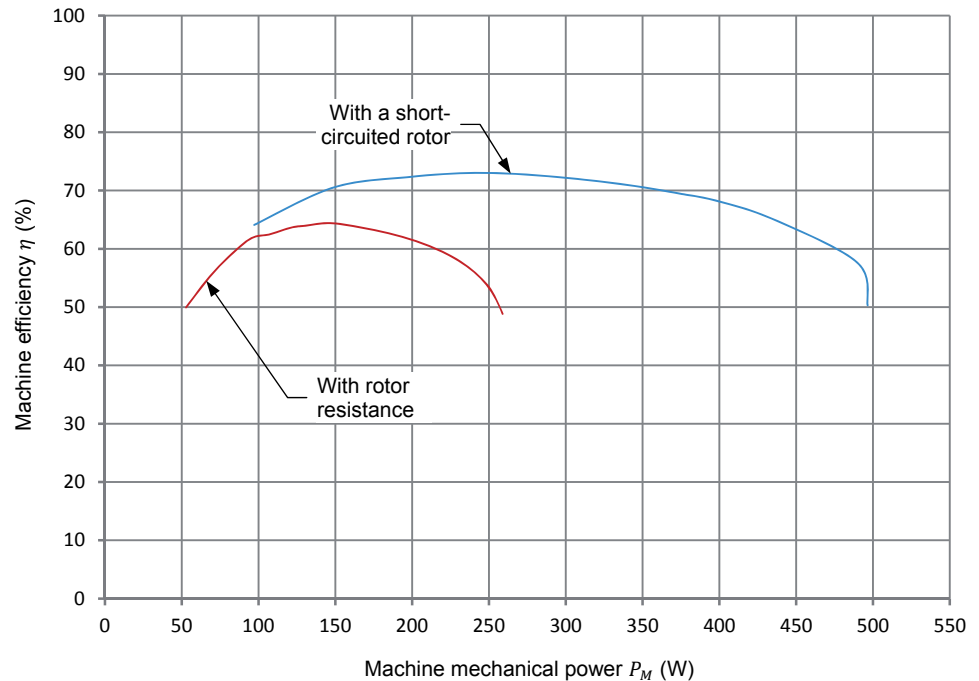

Three-phase wound-rotor induction machine efficiency η as a function of the machine mechanical power P_M with a short-circuited rotor, as well as with rotor resistance, when the machine operates as a motor.

Observe the graph. What is the effect, if any, of adding resistance to the rotor of a three-phase wound-rotor induction machine on the machine efficiency η during motor operation?

Adding resistance to the rotor lowers the machine efficiency η of a three-phase wound-rotor induction machine operating as a motor. The decrease in efficiency becomes more important as the mechanical power produced by the three-phase wound-rotor induction machine increases.

21. Close LVDAC-EMS, then turn off all the equipment. Disconnect all leads and return them to their storage location.

Ask your instructor to replace the 32 teeth pulley installed on the Three-Phase Wound-Rotor Induction Machine with a 24 teeth pulley.



Appendix E shows how to replace the pulley installed on the shaft of a supplied machine.

CONCLUSION

In this exercise, you learned the effects of varying the rotor resistance of a three-phase wound-rotor induction machine on the machine starting current and torque, as well as on the machine rotation speed and efficiency.

REVIEW QUESTIONS

1. Describe the effect of increasing the rotor resistance of a three-phase wound-rotor induction machine on the machine starting current.

Increasing the rotor resistance of a three-phase wound-rotor induction machine reduces the amount of current drawn by the machine during start-up.

2. Describe the effect of increasing the rotor resistance of a three-phase wound-rotor induction machine on the machine starting torque.

Increasing the rotor resistance of a three-phase wound-rotor induction machine shifts toward the left the breakdown torque region on the machine torque versus speed curve. Thus, the higher the machine rotor resistance (up to a certain value), the higher the machine starting torque.

3. Why is the rotor resistance of a three-phase wound-rotor induction machine usually short-circuited after the machine initial start-up?

After the initial start-up of a three-phase wound-rotor induction machine, a high rotor resistance causes the torque produced by the machine to decrease rapidly as the machine speed increases. This is why the machine rotor resistance is usually short-circuited after initial start-up to optimize the torque produced by the machine.

4. How is it possible to vary the speed of a three-phase wound-rotor induction machine?

It is possible to vary the speed of a three-phase wound-rotor induction machine by varying the machine rotor resistance. The higher the machine rotor resistance, the lower the machine speed for a given torque.

5. What is the main drawback of lowering the speed of a three-phase wound-rotor induction machine using the machine rotor resistance?

The main drawback of lowering the speed of a three-phase wound-rotor induction machine by increasing the machine rotor resistance is the reduction of the machine efficiency. This is because increasing the machine rotor resistance increases the active power losses (I^2R).

Bibliography

Wildi, Theodore, *Electrical Machines, Drives, and Power Systems*, 6th Edition, Upper Saddle River, Prentice Hall, 2005, ISBN 978-0131776913.