

Electricity and New Energy

Hydropower Electricity Generation

Courseware Sample

86369-F0

Order no.: 86369-10
First Edition
Revision level: 08/2016

By the staff of Festo Didactic

© Festo Didactic Ltée/Ltd, Quebec, Canada 2013
Internet: www.festo-didactic.com
e-mail: did@de.festo.com

Printed in Canada
All rights reserved
ISBN 978-2-89640-576-3 (Printed version)
ISBN 978-2-89640-577-0 (CD-ROM)
Legal Deposit – Bibliothèque et Archives nationales du Québec, 2013
Legal Deposit – Library and Archives Canada, 2013

The purchaser shall receive a single right of use which is non-exclusive, non-time-limited and limited geographically to use at the purchaser's site/location as follows.

The purchaser shall be entitled to use the work to train his/her staff at the purchaser's site/location and shall also be entitled to use parts of the copyright material as the basis for the production of his/her own training documentation for the training of his/her staff at the purchaser's site/location with acknowledgement of source and to make copies for this purpose. In the case of schools/technical colleges, training centers, and universities, the right of use shall also include use by school and college students and trainees at the purchaser's site/location for teaching purposes.

The right of use shall in all cases exclude the right to publish the copyright material or to make this available for use on intranet, Internet and LMS platforms and databases such as Moodle, which allow access by a wide variety of users, including those outside of the purchaser's site/location.

Entitlement to other rights relating to reproductions, copies, adaptations, translations, microfilming and transfer to and storage and processing in electronic systems, no matter whether in whole or in part, shall require the prior consent of Festo Didactic.

















Information in this document is subject to change without notice and does not represent a commitment on the part of Festo Didactic. The Festo materials described in this document are furnished under a license agreement or a nondisclosure agreement.

Festo Didactic recognizes product names as trademarks or registered trademarks of their respective holders.

All other trademarks are the property of their respective owners. Other trademarks and trade names may be used in this document to refer to either the entity claiming the marks and names or their products. Festo Didactic disclaims any proprietary interest in trademarks and trade names other than its own.

Safety and Common Symbols

The following safety and common symbols may be used in this manual and on the equipment:

| Symbol | Description |
|---|---|
|  | DANGER indicates a hazard with a high level of risk which, if not avoided, will result in death or serious injury. |
|  | WARNING indicates a hazard with a medium level of risk which, if not avoided, could result in death or serious injury. |
|  | CAUTION indicates a hazard with a low level of risk which, if not avoided, could result in minor or moderate injury. |
|  | CAUTION used without the <i>Caution, risk of danger</i> sign  , indicates a hazard with a potentially hazardous situation which, if not avoided, may result in property damage. |
|  | Caution, risk of electric shock |
|  | Caution, hot surface |
|  | Caution, risk of danger |
|  | Caution, lifting hazard |
|  | Caution, hand entanglement hazard |
|  | Notice, non-ionizing radiation |
|  | Direct current |
|  | Alternating current |
|  | Both direct and alternating current |
|  | Three-phase alternating current |
|  | Earth (ground) terminal |

Safety and Common Symbols









| Symbol | Description |
|--|--|
|  | Protective conductor terminal |
|  | Frame or chassis terminal |
|  | Equipotentiality |
|  | On (supply) |
|  | Off (supply) |
|  | Equipment protected throughout by double insulation or reinforced insulation |
|  | In position of a bi-stable push control |
|  | Out position of a bi-stable push control |

Table of Contents

| | |
|---|-----------|
| Preface | IX |
| About This Manual | XI |
| To the Instructor | XIII |
| Introduction Hydropower Electricity Generation | 1 |
| DISCUSSION OF FUNDAMENTALS | 1 |
| Hydropower | 1 |
| Types of hydropower plants | 2 |
| Dam hydropower plants | 3 |
| Run-of-river hydropower plants..... | 3 |
| Tidal hydropower plants | 4 |
| Main components of a typical dam hydropower plant | 5 |
| Dam, water reservoir, water output, and spillway..... | 6 |
| Intake, penstock, control gate, and vanes..... | 7 |
| Water turbine and draft tube | 8 |
| Generator, power transformer, and ac transmission lines..... | 11 |
| Available power in a hydropower plant..... | 12 |
| Advantages and disadvantages of hydropower electricity generation..... | 13 |
| Advantages of hydropower electricity generation..... | 13 |
| Disadvantages of hydropower electricity generation..... | 14 |
| Exercise 1 Generator Frequency and Voltage Control Principles | 17 |
| DISCUSSION | 17 |
| Effect of resistive load variations on the operation of a turbine-driven synchronous generator..... | 17 |
| Effect of inductive load variations on the operation of a turbine-driven synchronous generator..... | 21 |
| Frequency control of a turbine-driven synchronous generator | 23 |
| Voltage control of a synchronous generator..... | 25 |
| Auto-excited brushless synchronous generators | 27 |
| PROCEDURE | 30 |
| Set up and connections | 30 |
| Generator frequency and voltage manual control | 36 |
| Log of generator frequency and voltage in manual generator operation | 59 |

Table of Contents

| | | |
|-------------------|---|-----------|
| Exercise 2 | Generator Synchronization Using a Synchro-Check Relay..... | 67 |
| | DISCUSSION..... | 67 |
| | Generator synchronization using a synchro-check relay..... | 67 |
| | Main synchronization parameters of a synchro-check relay | 69 |
| | Frequency difference (Δf)..... | 70 |
| | Voltage difference (ΔE) | 70 |
| | Phase angle difference ($\Delta\phi$)..... | 70 |
| | Synchronization window | 71 |
| | Circuit-breaker operate time | 72 |
| | Distinction between a live bus, an infinite bus, and a dead bus | 73 |
| | Connecting a synchronous generator to a dead bus..... | 75 |
| | PROCEDURE | 76 |
| | Set up and connections | 76 |
| | Synchro-check relay operation (connection to a dead bus)..... | 83 |
| | Synchro-check relay operation (synchronization to a live bus)..... | 86 |
| | Effects of the synchro-check relay parameter settings on the electrical transients and mechanical stress at generator synchronization | 94 |
| | Active and reactive power control of a turbine-driven generator after connection to a live infinite bus..... | 102 |
| Exercise 3 | Generator Operation with Speed and Voltage Regulation... 109 | |
| | DISCUSSION..... | 109 |
| | Operation of the speed governor..... | 109 |
| | Operation of the automatic voltage regulator (AVR) | 113 |
| | Operation of a synchronous generator in isochronous and fixed voltage control modes when connected to an infinite bus..... | 118 |
| | Synchronous generator in isochronous mode connected to an infinite bus | 119 |
| | Synchronous generator in fixed voltage mode connected to an infinite bus | 120 |

Table of Contents

| | |
|--|------------|
| PROCEDURE | 121 |
| Set up and connections | 122 |
| Operation of a synchronous generator in isochronous and fixed voltage control modes when connected to a dead bus | 129 |
| Log of the frequency and voltage of a synchronous generator operating in isochronous mode and fixed voltage mode | 133 |
| Operation of a synchronous generator in isochronous and fixed voltage control modes when connected to an infinite bus..... | 138 |
| | |
| Exercise 4 Generator Speed and Voltage Regulation with Droop | 151 |
| DISCUSSION..... | 151 |
| Generator speed regulation with droop | 151 |
| Block diagram of a hydropower generator with a speed governor operating in speed droop mode | 155 |
| Generator voltage regulation with droop | 158 |
| Block diagram of a hydropower generator with an AVR operating in voltage droop mode..... | 161 |
| Generator var regulation..... | 165 |
| PROCEDURE | 167 |
| Set up and connections | 167 |
| Speed governor regulation characteristics | 173 |
| Automatic voltage regulator (AVR) voltage regulation characteristics..... | 177 |
| Generator speed regulation with droop (when connected to an infinite bus) | 182 |
| Generator voltage regulation with droop (when connected to an infinite bus)..... | 188 |
| | |
| Exercise 5 Generator Parallel Operation and Load Sharing (Optional) | 195 |
| DISCUSSION..... | 195 |
| Need for operating synchronous generators in parallel and associated benefits..... | 195 |
| Setting up synchronous generators for parallel operation... .. | 196 |
| Active power sharing..... | 198 |
| Reactive power sharing..... | 201 |
| Frequency controller and voltage controller | 205 |
| Starting up a multiple-generator system..... | 208 |

Table of Contents

| | |
|--|------------|
| PROCEDURE | 210 |
| Set up and connections | 211 |
| Active power sharing (kW load sharing) between generators connected to the same bus | 216 |
| Reactive power sharing (kvar load sharing) between generators connected to the same bus | 236 |
| Appendix A Equipment Utilization Chart | 245 |
| Appendix B Glossary of New Terms | 247 |
| Appendix C Impedance Table for the Load Modules | 251 |
| Appendix D Circuit Diagram Symbols | 253 |
| Appendix E Introduction to SCADA Systems | 259 |
| Index of New Terms | 263 |
| Bibliography | 265 |

Preface

The production of energy using renewable natural resources such as wind, sunlight, rain, tides, geothermal heat, etc., has gained much importance in recent years as it is an effective means of reducing greenhouse gas (GHG) emissions. The need for innovative technologies to make the grid smarter has recently emerged as a major trend, as the increase in electrical power demand observed worldwide makes it harder for the actual grid in many countries to keep up with demand. Furthermore, electric vehicles (from bicycles to cars) are developed and marketed with more and more success in many countries all over the world.

To answer the increasingly diversified needs for training in the wide field of electrical energy, the Electric Power Technology Training Program was developed as a modular study program for technical institutes, colleges, and universities. The program is shown below as a flow chart, with each box in the flow chart representing a course.

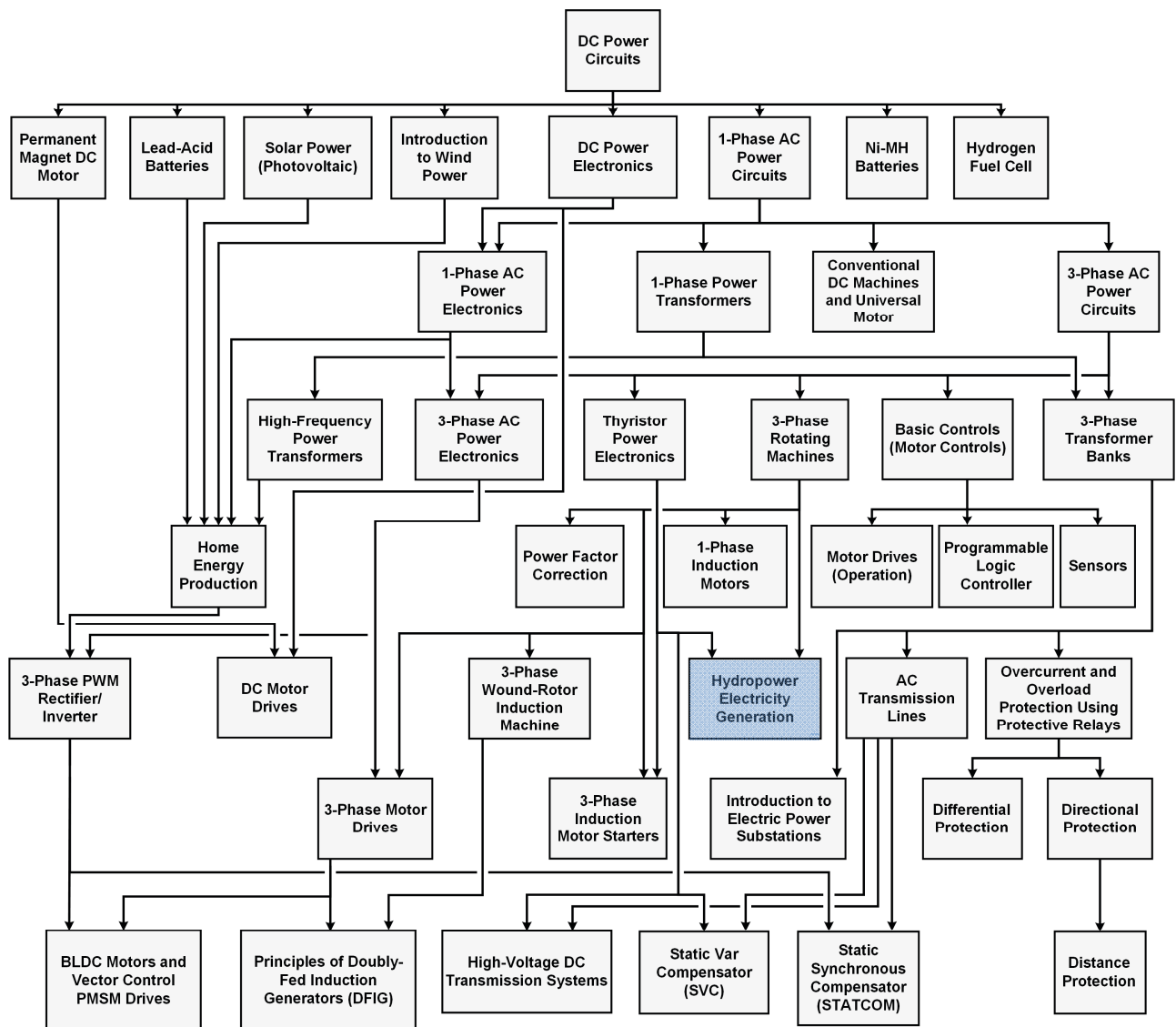

The Electric Power Technology Training Program.

Preface

The program starts with a variety of courses providing in-depth coverage of basic topics related to the field of electrical energy such as ac and dc power circuits, power transformers, rotating machines, ac power transmission lines, and power electronics. The program then builds on the knowledge gained by the student through these basic courses to provide training in more advanced subjects such as home energy production from renewable resources (wind and sunlight), large-scale electricity production from hydropower, large-scale electricity production from wind power (doubly-fed induction generator [DFIG], synchronous generator, and asynchronous generator technologies), smart-grid technologies (SVC, STATCOM, HVDC transmission, etc.), storage of electrical energy in batteries, and drive systems for small electric vehicles and cars.

We invite readers of this manual to send us their tips, feedback, and suggestions for improving the book.

Please send these to did@de.festo.com.

The authors and Festo Didactic look forward to your comments.

About This Manual

Hydropower electricity generation is the most common type of energy production using renewable resources, and accounts for more than 15% of global electricity production. It uses hydropower (i.e., the power derived from the weight or motion of water) to generate electrical power. Due to the availability of water and the large quantities of electricity that can be generated using hydropower, most countries in the world have at least one hydropower facility used to generate electricity.

Hydropower electricity generation presents many advantages over other forms of electricity generation. The primary advantage of hydropower is that its prime mover, water, is renewable and free. Because of this, hydropower is one of the cheapest forms of electricity generation. Hydropower also produces very few CO₂ emissions in comparison to other forms of electricity generation, such as those using fossil fuel combustion. Finally, hydropower is very flexible since the flow of water in the turbines of a dam hydropower plant can be increased or decreased as required to meet the electrical power demand in real time.

This course teaches the basic concepts of hydropower electricity generation. Students are introduced to the different types of hydropower plants, as well as to the different components of a typical hydropower plant. They learn how to synchronize the synchronous generators in a hydropower plant. They also learn how to regulate the speed (frequency) and voltage of the generators. Finally, the theory presented in the manual is verified by performing various circuit measurements and observations.



Figure 1. The Three-Gorges Dam on the Yangtze River in China has a total installed capacity of 20 300 MW (photo courtesy of Le Grand Portage).

About This Manual

Safety considerations

Safety symbols that may be used in this manual and on the equipment are listed in the Safety Symbols table at the beginning of the manual.

Safety procedures related to the tasks that you will be asked to perform are indicated in each exercise.

Make sure that you are wearing appropriate protective equipment when performing the tasks. You should never perform a task if you have any reason to think that a manipulation could be dangerous for you or your teammates.

Prerequisite

As a prerequisite to this course, you should have read the manuals titled *DC Power Circuits*, part number 86350, *Single-Phase AC Power Circuits*, part number 86358, *Three-Phase AC Power Circuits*, part number 86360, *Thyristor Power Electronics*, part number 86363, and *Three-Phase Rotating Machines*, part number 86364.

Systems of units

Units are expressed using the International System of Units (SI) followed by units expressed in the U.S. customary system of units (between parentheses).

To the Instructor

You will find in this Instructor Guide all the elements included in the Student Manual together with the answers to all questions, results of measurements, graphs, explanations, suggestions, and, in some cases, instructions to help you guide the students through their learning process. All the information that applies to you is placed between markers and appears in red.

Accuracy of measurements

The numerical results of the hands-on exercises may differ from one student to another. For this reason, the results and answers given in this manual should be considered as a guide. Students who correctly performed the exercises should expect to demonstrate the principles involved and make observations and measurements similar to those given as answers.

Sample Exercise
Extracted from
the Student Manual
and the Instructor Guide

Hydropower Electricity Generation

MANUAL OBJECTIVE

When you have completed this manual, you will be familiar with the generation of electricity using hydropower. You will know the principles governing the control of the frequency and voltage of a turbine-driven synchronous generator. You will be able to synchronize a synchronous generator to an ac power system using a synchro-check relay. You will be familiar with the speed regulation of a turbine-driven synchronous generator using a speed governor operating in isochronous mode or speed droop mode, as well as with the generator voltage regulation using an automatic voltage regulator operating in fixed voltage mode or voltage droop mode. You will also be familiar with the synchronization and operation of multiple parallel-connected synchronous generators.

DISCUSSION OUTLINE

The Discussion of Fundamentals covers the following points:

- Hydropower
- Types of hydropower plants
Dam hydropower plants. Run-of-river hydropower plants. Tidal hydropower plants.
- Main components of a typical dam hydropower plant
Dam, water reservoir, water output, and spillway. Intake, penstock, control gate, and vanes. Water turbine and draft tube. Generator, power transformer, and ac transmission lines.
- Available power in a hydropower plant
- Advantages and disadvantages of hydropower electricity generation
Advantages of hydropower electricity generation. Disadvantages of hydropower electricity generation.

DISCUSSION OF FUNDAMENTALS

Hydropower

Hydropower, the power derived from the weight or motion of water, has been used since antiquity. Mesopotamians and Egyptians harnessed the power of water for irrigation as early as the 6th millennium BC. For centuries, Indians, Romans, and the Hellenistic civilizations used water to drive mechanical devices such as water wheels, mainly in watermills used to grind grain into flour. In Europe, the use of water wheels became widespread around the tenth century. During the late middle ages, water wheels began to be used as power sources for an increasing number of applications, such as pumps, hammers, and saws.



Figure 2. Since ancient times, humans have used dams to harness the power of water. The above figure shows the Cornalvo Dam, in Spain, built by the romans in the 1st or 2nd century AD (photo courtesy of Charly Morlock).

In the early 19th century, however, water wheels began to be gradually replaced by steam engines. At the beginning of the 20th century, hydropower once again came into common use, almost exclusively in the form of **hydroelectricity**, (i.e., electrical power obtained from the conversion of the mechanical power of flowing or falling water). Since the development of hydroelectricity, the construction of dams and hydropower plants has been constantly increasing. Nowadays, in many countries such as China, Canada, and Brazil, a large proportion of the total electrical power production derives from hydropower.

Types of hydropower plants

There are several types of hydropower plants, each of them harnessing hydropower through different means. The main types are listed below:

- Dam hydropower plant
- Run-of-river hydropower plant
- Tidal hydropower plant

Dam hydropower plants

Dam hydropower plants are by far the most common way of harnessing the power of water. The main feature of a dam hydropower plant is the dam itself. The construction of the dam on a river or any sufficient body of water floods the area upstream and creates a water reservoir. This reservoir allows the plant to operate according to the electrical power demand (i.e., to operate at full capacity during peak hours of energy consumption and to accumulate water during hours of low energy consumption). The power generated using a dam hydropower plant depends on the volume of water used, as well as the height difference between the water level in the reservoir and the water level at the water output of the plant. Unless specifically stated otherwise, the principles of hydropower covered in this manual concern dam hydropower plants.



Figure 3. The Sayano-Shushenskaya dam hydropower plant in Russia is one of the largest in the world. Its installed capacity is 6400 MW (photo courtesy of MVValt).

Run-of-river hydropower plants

Run-of-river hydropower plants are another way of harnessing the power of water. Run-of-river hydropower plants are generally installed along rivers with a high flow rate. They harness the natural flow and elevation drop of a river to produce electrical power. Run-of-river hydropower plants have no sizeable water reservoir, which means that they cannot operate according to the electrical power demand like dam hydropower plants do. Because of these factors, run-of-river hydropower plants are generally much smaller in size, have a lower power output, and are much less adaptable to variations in energy consumption than dam hydropower plants. Although run-of-river hydropower plants are not specifically covered in this manual, most of the principles behind the operation of dam hydropower plants can be applied to the operation of run-of-river hydropower plants.

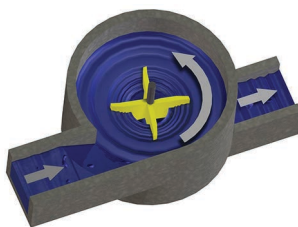

Figure 4. Water flow in the turbine of a run-of-river hydropower plant.



Figure 5. View of the Chief Joseph Dam hydropower plant on the Columbia River in the state of Washington, USA. The Chief Joseph Dam is a run-of-river hydropower plant with a capacity of 2600 MW.

Tidal hydropower plants

Tidal hydropower plants are less common than dam and run-of-river hydropower plants. They are generally installed near bodies of water having a significant height difference between high and low tides. This enables the plant to harness the power of ebbing and flowing tides. Tidal hydropower plants have a relatively low power rating. However, since tides are due to gravitational interaction between the Moon and Sun and the Earth's rotation, the power output of tidal hydropower plants is extremely constant and predictable in comparison to other types of hydropower plants. The principles behind tidal hydropower plants are not covered in this manual.



Figure 6. Tidal hydropower plant in Rance, France. It is the world's first large-scale tidal hydropower plant and has a peak power rating of 240 MW (photo courtesy of User:Dany 7C3).

Main components of a typical dam hydropower plant

Figure 7 shows the simplified diagram of a typical dam hydropower plant.

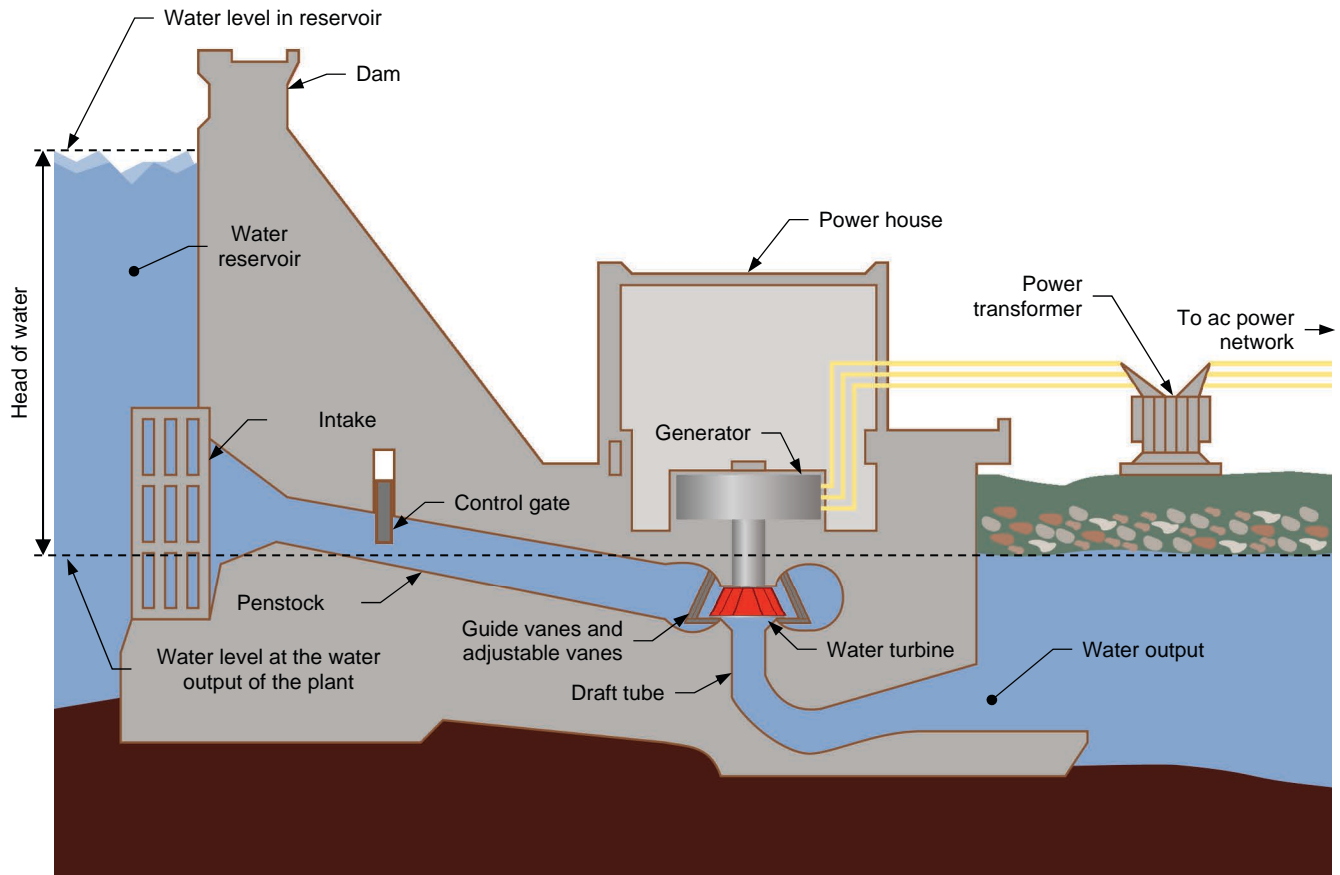

Figure 7. Simplified diagram of a typical dam hydropower plant.

The main components of the dam hydropower plant shown in Figure 7 are described in detail in the following subsections.

Dam, water reservoir, water output, and spillway

The dam in a hydropower plant impedes water flow from the river, creating a water reservoir. The dam is very important as it allows large quantities of water to be stored during rainy periods. This stored water can then be used as required during periods of drought. This means that, if the level of water in the reservoir of the hydropower plant is regulated effectively, the plant can generate the amount of electrical power required even during periods of low precipitation. In this way, a dam hydropower plant operates just like a battery. It stores energy (i.e., it stores water in the reservoir) and then supplies energy (i.e., it releases water from the reservoir via the turbines) as needed.

The dam also ensures that water from the reservoir falls by a certain height before reaching the turbines and being released at the water output of the hydropower plant. The difference in height between the water level in the reservoir and the water level at the hydropower plant output is called the **head of water** of the dam (see Figure 7). This characteristic is important as it greatly influences the total power output of the hydropower plant. The total power output of hydropower plants is covered in detail later in this Introduction.

Most dam hydropower plants include a water spillway (not illustrated in Figure 7) allowing any excess water in the reservoir to be released without passing through the turbines. The spillway can either be controlled using a gate, or be uncontrolled, simply allowing water to flow when the level of water becomes too high.



Figure 8. Water spillway from the Robert-Bourassa dam hydropower plant in the province of Quebec, Canada. With a total installed capacity of 5600 MW, the Robert-Bourassa dam hydropower plant is among the largest in North America (photo courtesy of fargomeD).

Intake, penstock, control gate, and vanes

The intake of a dam hydropower plant is an opening in the dam that channels water into the penstock. The intake usually contains a large iron or steel grate used to filter the water that flows from the reservoir to the penstock. This component is necessary to prevent large objects such as logs, rocks, and debris from entering and obstructing the penstock.

The penstock of the dam hydropower plant is a long and relatively narrow tunnel delivering water from the reservoir to the turbines. The purpose of the penstock is to ensure that water velocity and pressure are maximal before reaching the turbines.

The control gate of the dam hydropower plant is generally a heavy vertical gate used to regulate or shut-off the flow of water in the penstock. This gate is not intended for precise regulation of the water flowing in the turbine (as are the adjustable vanes).

The guide vanes (also called guide blades) are vanes installed in a loose circle around each hydraulic turbine of the dam hydropower plant. Guide vanes direct the flow of water so that it enters the turbine at the most suitable angle. Guide vanes are stationary and cannot be adjusted to regulate water flow.

The adjustable vanes (also called adjustable blades) are vanes installed in a tight circle around each hydraulic turbine of the dam hydropower plant (see Figure 9). Adjustable vanes regulate the amount of water that enters the turbines at any moment. By dynamically adjusting the opening of the vanes between fully closed (no water flows in the turbines) and fully open (the amount of water flowing in the turbines is maximal), it is possible to adjust the mechanical power at the synchronous generator shaft as needed and, consequently, to vary the amount of electrical power produced by the generators of the hydropower plant.

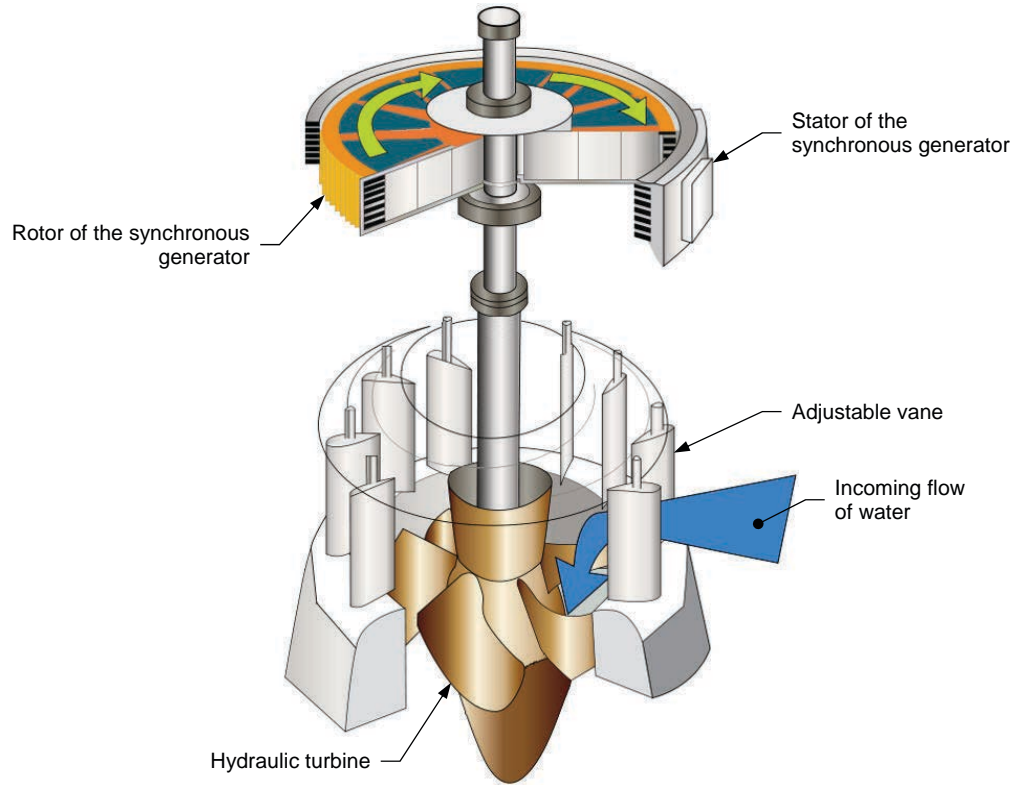

Figure 9. Cutaway view of a hydraulic turbine mechanically coupled to a synchronous generator showing the adjustable vanes that regulate the flow of water in the hydraulic turbine.

Water turbine and draft tube

Water turbines are one of the essential components of a hydropower plant. Depending on its size, a hydropower plant can contain between one turbine and a few dozen. The purpose of each water turbine is to convert the velocity and, in the case of dam hydropower plants, the pressure of the incoming water into mechanical energy that is used to drive a generator and produce electrical power. Several types of water turbines are available and each presents specific characteristics that are more or less adapted for any given application. The most common type of turbines used in dam hydropower plants are Francis turbines (shown in Figure 10).

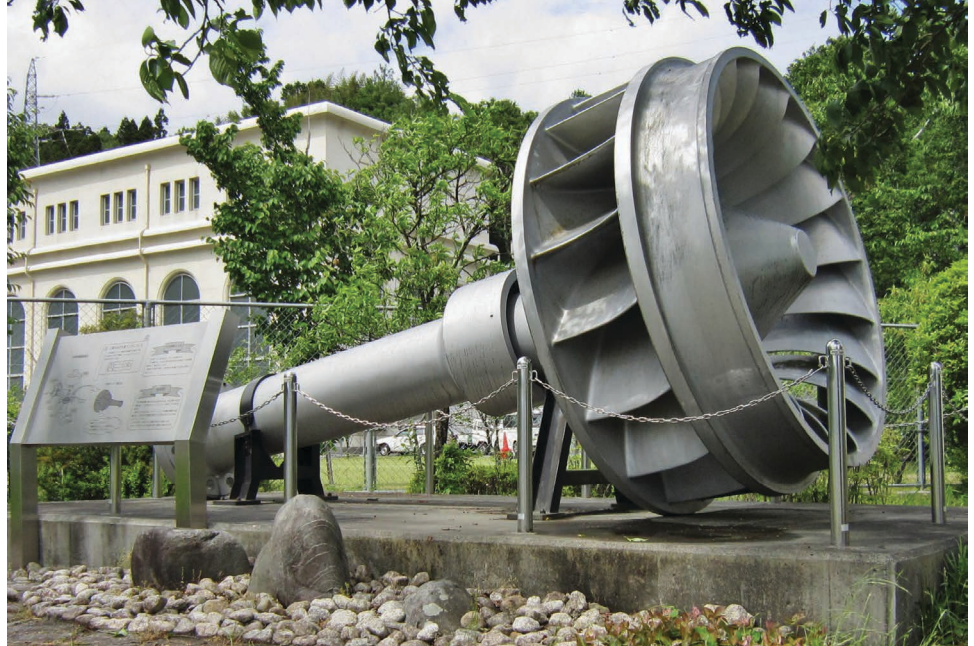

Figure 10. Typical Francis turbine, including the turbine shaft which is normally mechanically coupled to a synchronous generator (photo courtesy of Qurren).

Francis turbines are both radial and axial turbines. This is because water enters a Francis turbine radially (perpendicular to the turbine axis), then exits the turbine axially (parallel to the turbine axis). Francis turbines are also reaction turbines, which means that they convert both water velocity and water pressure into mechanical energy, as opposed to impulse turbines, which only convert water velocity into mechanical energy. Francis turbines have a very high efficiency, typically converting over 90% of the energy contained in the flow of water into mechanical energy.

The draft tube is located just below the turbine and serves the purpose of disposing of the water flowing through the turbines. Since the water exiting a turbine has lost most of its speed and pressure, it is essential to evacuate it as soon as possible so as not to slow or impede the incoming flow of water. The draft tube directs the exiting water into the river or body of water downstream of the dam.



Figure 11. One of the 29 currently installed Francis turbines in the Three-Gorges Dam hydropower plant in China. Each turbine has a power generating capacity of 700 MW (photo courtesy of Voith Siemens Hydro Power Generation).

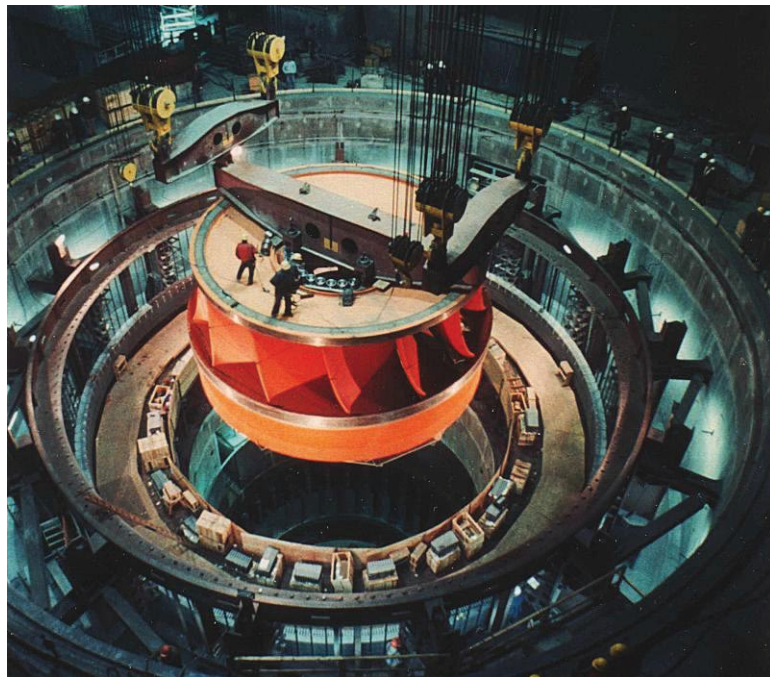

Figure 12. Installation of a large Francis turbine at the Grand Coulee dam, in the state of Washington, USA. The figure shows how water enters the turbine from the sides, then exits the turbine through the draft tube at the bottom.

Generator, power transformer, and ac transmission lines

Each water turbine in a hydropower plant is coupled to the shaft of a generator. The purpose of these generators is to convert the mechanical power at the water turbine into electrical power. The greater the volume of water flowing in the turbines and the higher the head of water of the hydropower plant, the higher the mechanical power at the water turbine and thus the higher the amount of electrical power produced by the generator. Virtually all generators used to produce electrical power in hydropower plants are synchronous generators. The synchronous generators in a hydropower plant are controlled using a controller consisting mainly of a **synchro-check relay**, a **speed governor**, and an **automatic voltage regulator**. The operation of synchronous generator controllers is covered in detail later in this manual.



Figure 13. View of the generator hall in the Sayano-Shushenskaya hydropower plant in Russia. A water turbine and synchronous generator assembly lies under each grey circle in the floor of the generator hall (photo courtesy of Andrey Korzun).

The electrical power produced by the synchronous generators is delivered to one or more power transformers. The purpose of power transformers is to increase the voltage of the electrical power produced by the generators to the high voltage value at which long ac transmission lines generally operate.



Figure 14. Power transformers used to step-up the voltage at the Robert Bourassa hydropower plant in the province of Quebec, Canada (photo courtesy of fargomeD).

Finally, after the voltage of the electrical power produced by the synchronous generators has been stepped-up to the required value, the electrical power is supplied to consumers via the transmission lines of the ac power network.

Available power in a hydropower plant

The total power output generated in a dam or run-of-river hydropower plants is calculated using the following equation:

$$P_{Total} = \eta\rho Qgh \quad (1)$$

- where P_{Total} is the total power output generated in the hydropower plant, expressed in watts (W).
- η is the overall efficiency of the hydropower plant, expressed as a coefficient ranging from 0 to 1.
- ρ is the density of the water flowing in the turbines of the hydropower plant, expressed in kilograms per cubic meter (kg/m^3).
- Q is the flow rate of the water flowing in the turbines of the hydropower plant, expressed in cubic meters per second (m^3/s).
- g is the Earth's gravitational constant, expressed in meters per square second (m/s^2).
- h is the falling height, or head of water, of the water flowing in the turbines of the hydropower plant, expressed in meters (m).

As Equation (1) shows, five parameters determine the total power output P_{Total} of a hydropower plant. Of these parameters, two are constants (water density ρ and Earth's gravitational constant g) which cannot be modified. Another parameter, the hydropower plant's overall efficiency η , encompasses the efficiency of the turbines and synchronous generators, as well as that of the water conduits, and can be maximized by proper selection and operation of the equipment in the hydropower plant. This means that only two parameters intrinsic to the chosen location of a hydropower plant influence the total power output of the plant: the water flow rate Q and the water falling height h , or head of water (see Figure 7). Therefore, it is important when determining the location of a hydropower plant to ensure that both of these parameters are as high as possible.

In dam hydropower plants, most of the plant's total power output is due to the head of water of the dam, although a significant portion is also derived from the water flow rate developed in the penstock of the dam. In run-of-river hydropower plants, however, almost all of the plant total power output is due to the water flow rate, and very little or none due to the head of water.

Advantages and disadvantages of hydropower electricity generation

The generation of electricity using hydropower presents both advantages and disadvantages. Only by careful consideration of every aspect of the construction of a hydropower plant can the feasibility and desirability of the project be evaluated. The advantages and disadvantages of hydroelectricity are listed below.

Advantages of hydropower electricity generation

- Renewable energy: hydropower electricity generation relies on water, a renewable resource (since it is continually renewed through the cycle of water) just as solar power and wind power. This is due to the prime mover of hydropower electricity generation being water.
- Low CO₂ emissions: hydropower electricity generation produces very few CO₂ emissions, especially in comparison to electricity generation through the combustion of fossil fuels such as coal and natural gases.
- Flexibility: hydropower electricity generation is very flexible. The power output of a hydropower plant can be increased and decreased very rapidly to meet the demand. The construction of a dam and a water reservoir even allows the plant to operate during periods of drought.
- Low power cost: once the hydropower plant is constructed, it can produce electricity at a very low cost, especially when compared to other types of electricity generation. This is because the prime mover of hydropower electricity generation (water) is free.



Figure 15. One of the main advantages of hydropower electricity generation is the renewability and availability of the prime mover (i.e., water), especially in comparison to electricity generation through the combustion of fossil fuels such as coal and natural gas.

Disadvantages of hydropower electricity generation

- Ecosystem loss: hydropower plants can have very significant effects on the ecosystem surrounding the plant. This is especially true with any dam hydropower plant, which necessitates the flooding of a large land area to obtain the water reservoir required. This can potentially result in the destruction of flora and fauna, as well as in the displacement of human populations.
- Water shortage: the amount of water flowing through a hydropower plant can decrease over the years depending on environmental conditions. This can greatly reduce the total power output of the plant and render it less productive. Seasonal droughts can also be a problem when no water reservoir is available (as for run-of-river hydropower plants) or when the water reservoir is too small.
- High initial costs: the initial construction costs of a hydropower plant are very high. This is especially true for dam hydropower plants, due to the high construction costs of the dam in addition to compensation money that must generally be paid to relocated populations.



Figure 16. The initial investments represented by a dam hydropower plant are very high and can only be repaid after several years of electricity production.

Generator Frequency and Voltage Control Principles

EXERCISE OBJECTIVE

When you have completed this exercise, you will be familiar with the effect of load variations on the operation of a turbine-driven synchronous generator. You will know how to control the frequency and voltage of a turbine-driven synchronous generator. You will be introduced to the operating principles of an auto-excited brushless synchronous generator.

DISCUSSION OUTLINE

The Discussion of this exercise covers the following points:

- Effect of resistive load variations on the operation of a turbine-driven synchronous generator
- Effect of inductive load variations on the operation of a turbine-driven synchronous generator
- Frequency control of a turbine-driven synchronous generator
- Voltage control of a synchronous generator
- Auto-excited brushless synchronous generators

DISCUSSION

Effect of resistive load variations on the operation of a turbine-driven synchronous generator

Figure 17 shows the simplified equivalent circuit representing one phase of a synchronous generator connected to a resistive-inductive load.

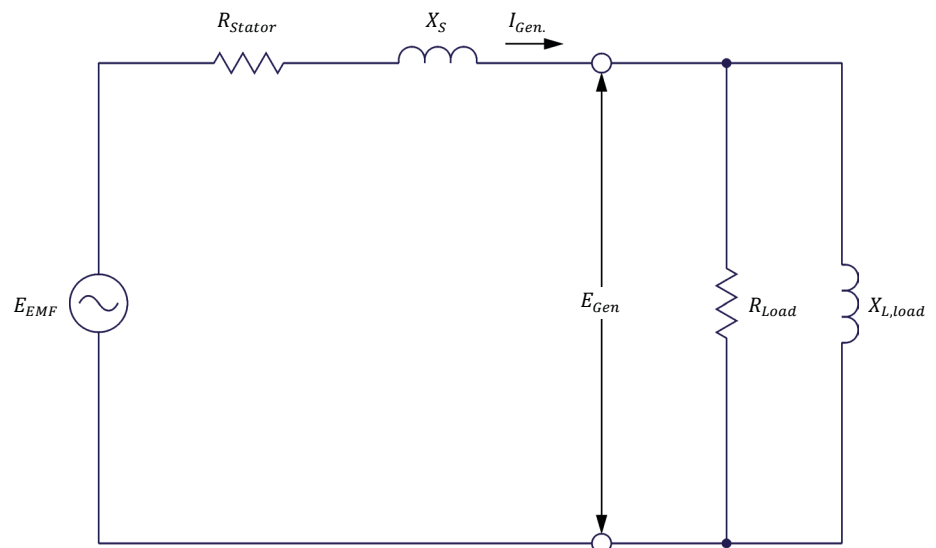

Figure 17. Simplified equivalent circuit representing one phase of a synchronous generator connected to a resistive-inductive load.

As Figure 17 shows, each phase of the synchronous generator consists of a resistor (representing the resistance R_{Stator} of each stator winding) and an inductor (representing the synchronous reactance X_S of each stator winding) connected in series with an ideal ac voltage source having a voltage value of E_{EMF} . Each phase is connected to a resistive-inductive load.

Figure 18 and Figure 19 show graphs of various electrical and mechanical parameters related to a turbine-driven synchronous generator as a function of time when the resistive load connected to the generator increases. Note that, in Figure 19, the synchronous generator speed $n_{Gen.}$ is of positive polarity and the synchronous generator torque $T_{Gen.}$ and mechanical power P_M are of negative polarity, since both of these parameters result from forces which oppose rotation of the generator.

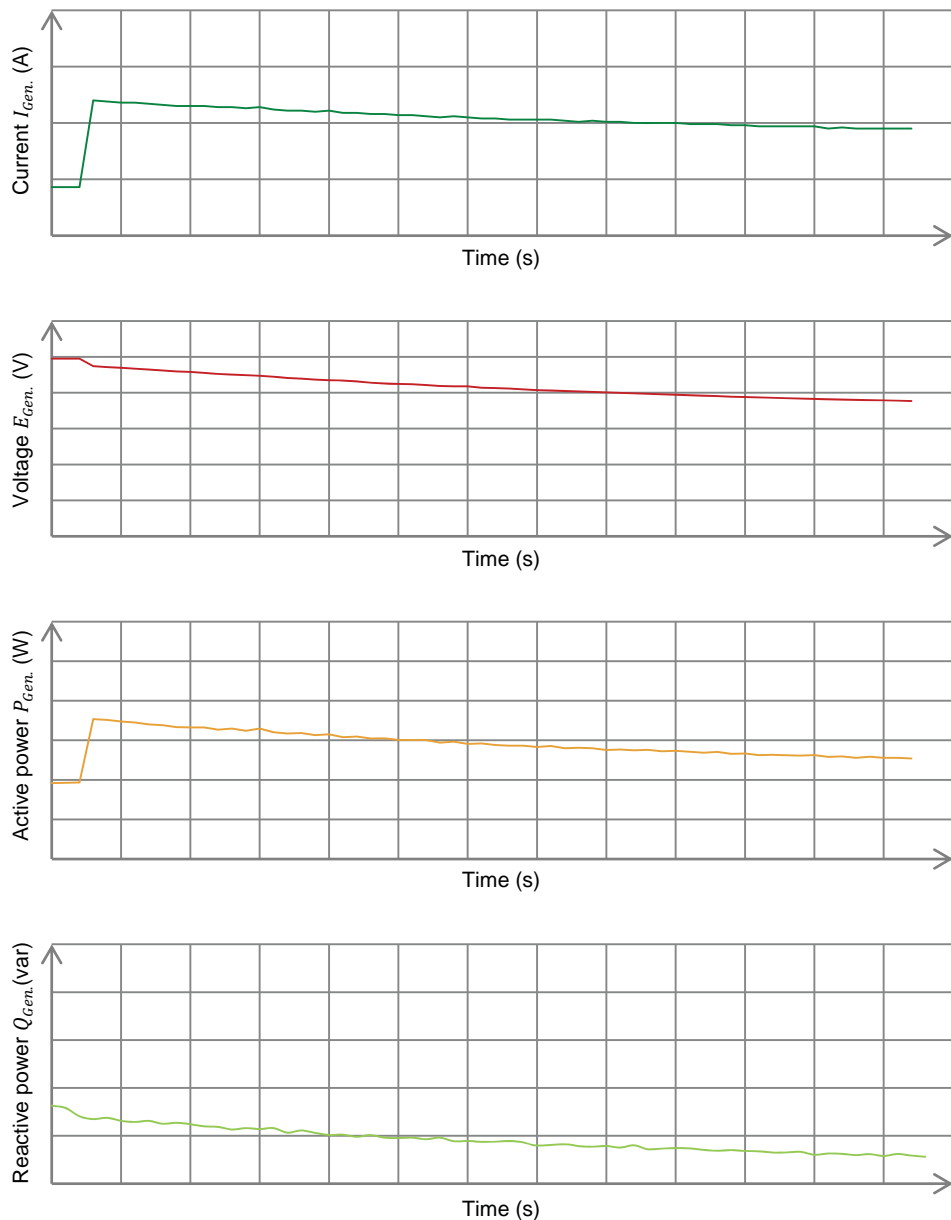

Figure 18. Graphs of various electrical parameters related to a turbine-driven synchronous generator as a function of time when the resistive load connected to the generator increases.

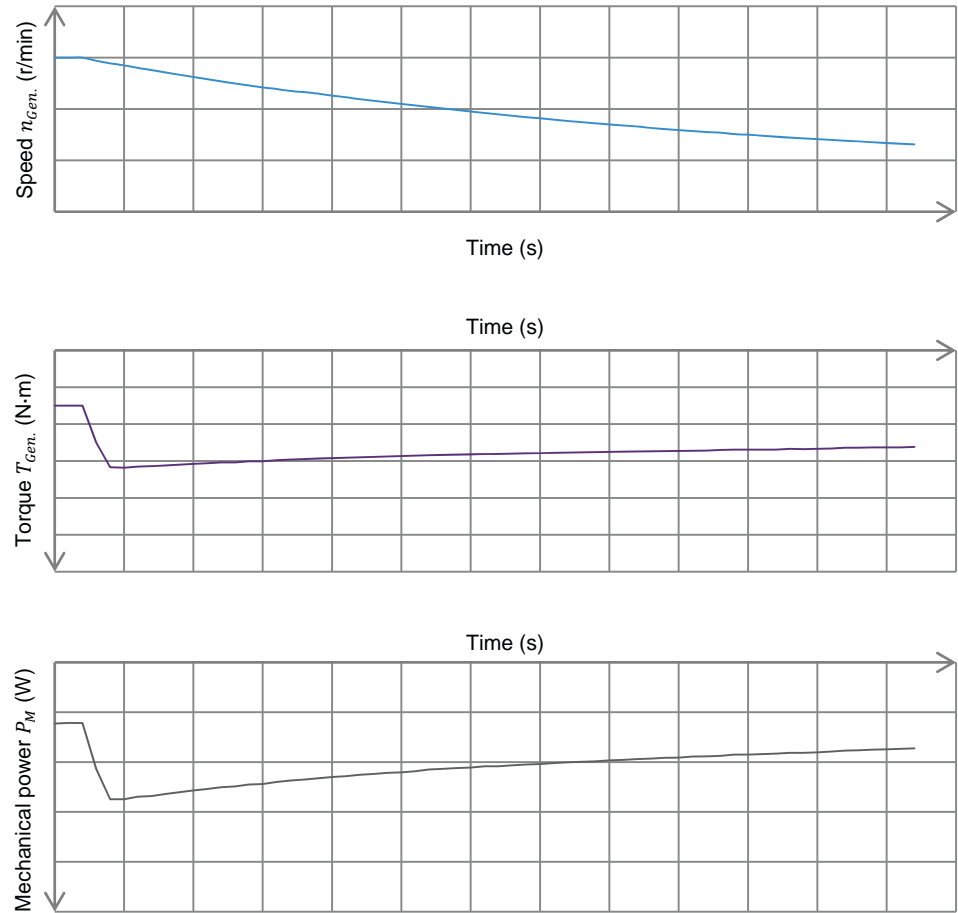

Figure 19. Graphs of various mechanical parameters related to a turbine-driven synchronous generator as a function of time when the resistive load connected to the generator increases.

When the resistive load connected to the turbine-driven synchronous generator increases, the generator current $I_{Gen.}$ increases instantaneously. This increase in the generator current $I_{Gen.}$ causes the voltage drop across the stator resistance R_{Stator} and the synchronous reactance X_S to also increase instantaneously; this, in turn, causes the generator voltage $E_{Gen.}$ to decrease instantaneously. Due to the increase in the generator current $I_{Gen.}$ being greater than the decrease in the generator voltage $E_{Gen.}$, the amount of active power $P_{Gen.}$ which the synchronous generator supplies to the resistive load increases (also instantaneously). Since the generator voltage $E_{Gen.}$ decreases, the amount of reactive power $Q_{Gen.}$ which the generator exchanges with the load decreases (instantaneously).

The sudden increase in the generator active power $P_{Gen.}$ causes the generator torque $T_{Gen.}$ to increase instantaneously. Since torque $T_{Gen.}$ opposes the torque applied by the hydraulic turbine to the synchronous generator shaft, this causes the generator speed $n_{Gen.}$ to decrease. However, due to the high inertia of the hydraulic turbine driving each synchronous generator in a hydropower plant, the generator speed $n_{Gen.}$ (and, consequently, the generator frequency $f_{Gen.}$) does not decrease instantaneously when the resistive load connected to the generator increases. Therefore, since the generator torque $T_{Gen.}$ increases and the generator speed $n_{Gen.}$ remains constant, the mechanical power P_M at the generator shaft increases instantaneously when the resistive load connected to the generator increases.

In brief, all of the synchronous generator parameters shown in Figure 18 and Figure 19, except the generator speed $n_{Gen.}$, vary instantaneously when the value of the resistive load connected to the generator changes.

After the increase in the resistive load, the generator speed $n_{Gen.}$ (and, consequently, the generator frequency $f_{Gen.}$) begins to decrease. The rate at which the generator speed $n_{Gen.}$ decreases depends on the inertia of the hydraulic turbine and on the magnitude of the increase in the resistive load. The higher the inertia of the hydraulic turbine and the smaller the magnitude of the increase in the resistive load, the slower the generator speed $n_{Gen.}$ decreases. Conversely, the lower the inertia of the hydraulic turbine and the greater the magnitude of the increase in the resistive load, the faster the generator speed $n_{Gen.}$ decreases.

As the generator speed $n_{Gen.}$ decreases after the increase in the resistive load, the other generator parameters also vary. The decrease in the generator speed $n_{Gen.}$ causes the generator voltage $E_{Gen.}$ to decrease, thereby decreasing the generator current $I_{Gen.}$, active power $P_{Gen.}$, and reactive power $Q_{Gen.}$. As the generator active power $P_{Gen.}$ decreases, the generator torque $T_{Gen.}$ also decreases. Since both the generator speed $n_{Gen.}$ and torque $T_{Gen.}$ decrease, the mechanical power P_M at the generator shaft also decreases. When the magnitude of the generator torque $T_{Gen.}$ once again becomes equal to the torque applied by the hydraulic turbine to the synchronous generator shaft, the generator speed $n_{Gen.}$ (as well as the other generator parameters) stabilize at a new operating point. The new steady-state values of the synchronous generator parameters mainly depend on the magnitude of the increase in the resistive load.

When the resistive load connected to a turbine-driven synchronous generator decreases, the effects on the generator parameters described above are reversed. This means that, when the resistive load decreases, the generator current $I_{Gen.}$, active power $P_{Gen.}$, torque $T_{Gen.}$, and mechanical power P_M decrease instantaneously, the generator voltage $E_{Gen.}$ and reactive power $Q_{Gen.}$ increase instantaneously, while the generator speed $n_{Gen.}$ (and thus the generator frequency $f_{Gen.}$) remains virtually constant. After the decrease in the resistive load, the generator speed $n_{Gen.}$ begins to increase. Therefore, the generator voltage $E_{Gen.}$, current $I_{Gen.}$, active power $P_{Gen.}$, reactive power $Q_{Gen.}$, torque $T_{Gen.}$, and mechanical power P_M increase with the generator speed $n_{Gen.}$. When the generator torque $T_{Gen.}$ once again becomes equal to the torque applied by the hydraulic turbine to the synchronous generator shaft, the generator speed $n_{Gen.}$, as well as the other generator parameters, stabilize at a new operating point. The new steady-state values of the synchronous generator parameters mainly depend on the magnitude of the decrease in the resistive load.

Effect of inductive load variations on the operation of a turbine-driven synchronous generator

Figure 20 and Figure 21 show graphs of various electrical and mechanical parameters related to a turbine-driven synchronous generator as a function of time when the inductive load connected to the generator increases. Note that, in Figure 21, the synchronous generator speed $n_{Gen.}$ is of positive polarity and the synchronous generator torque $T_{Gen.}$ and mechanical power P_M are of negative polarity, since both of these parameters oppose rotation of the generator.

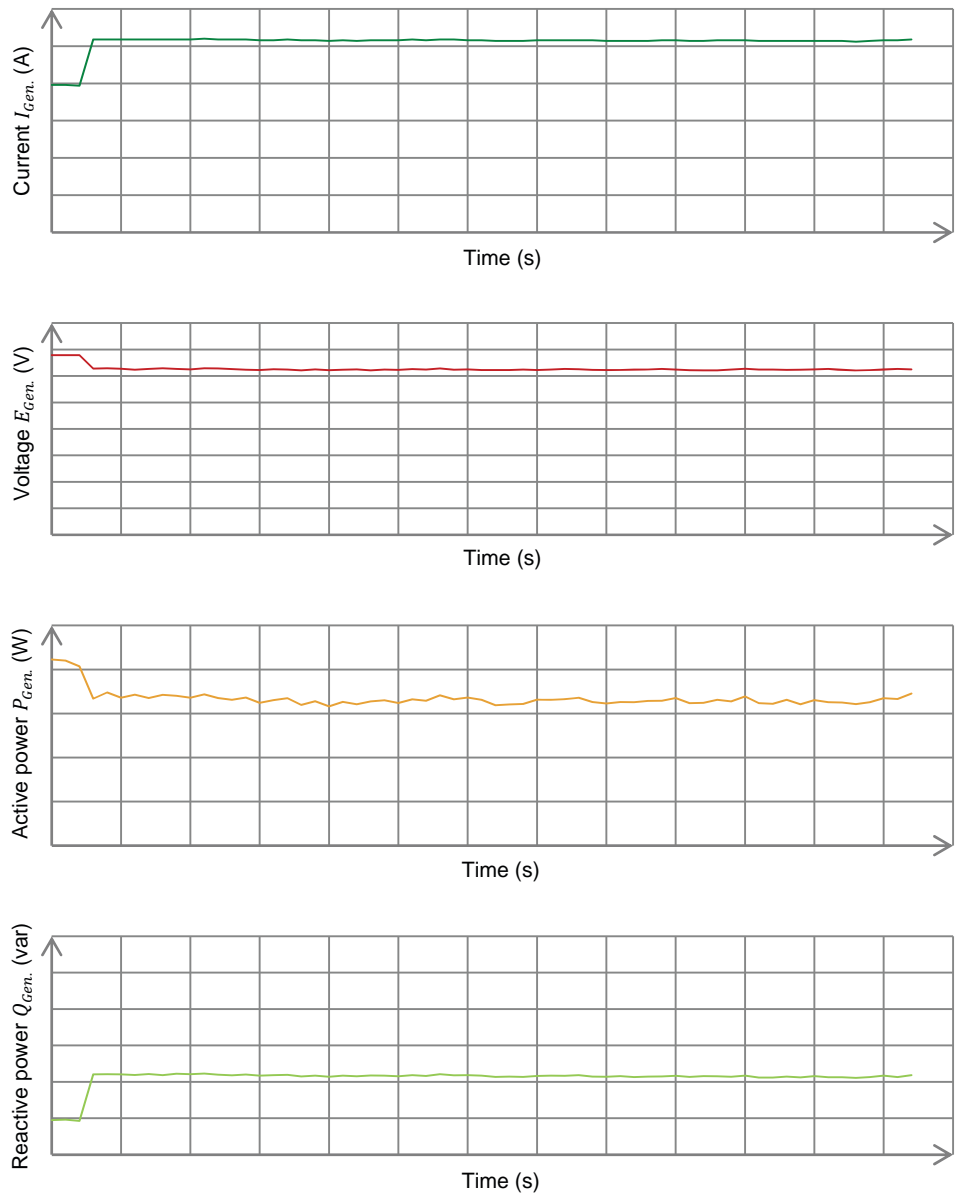

Figure 20. Graphs of various electrical parameters related to a turbine-driven synchronous generator as a function of time when the inductive load connected to the generator increases.

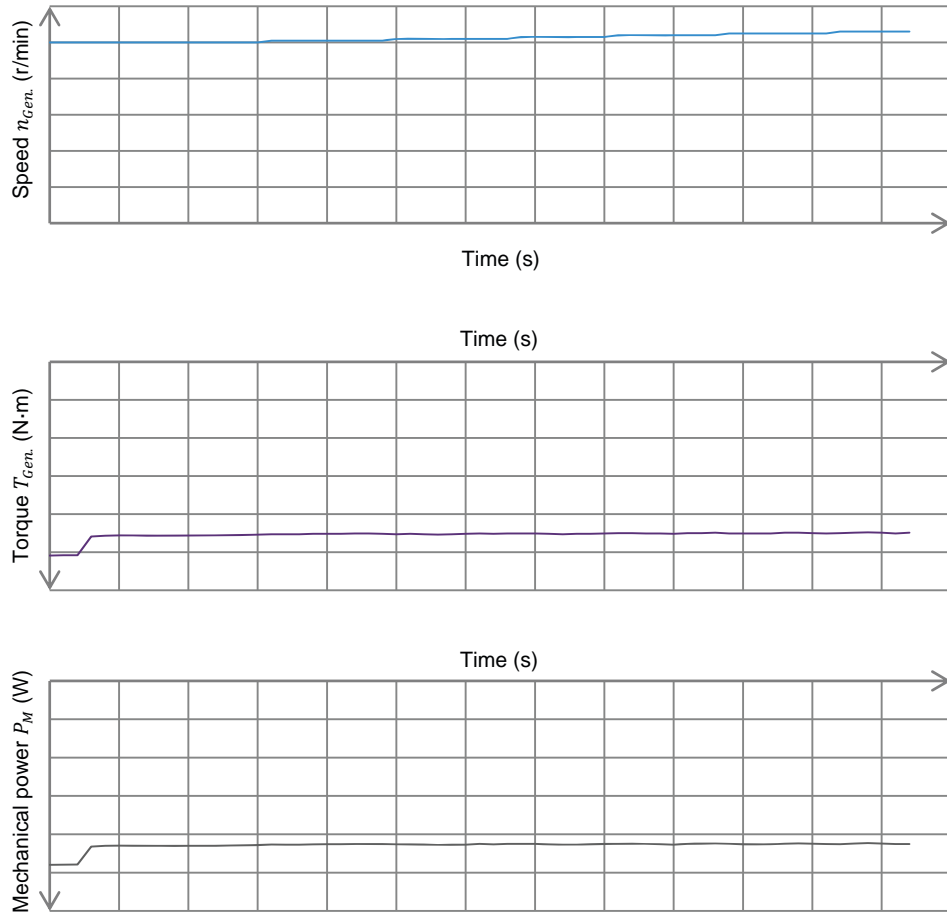

Figure 21. Graphs of various mechanical parameters related to a turbine-driven synchronous generator as a function of time when the inductive load connected to the generator increases.

When the inductive load connected to the turbine-driven synchronous generator increases, the generator current $I_{Gen.}$ and reactive power $Q_{Gen.}$ both increase instantaneously. The increase in the generator current $I_{Gen.}$ also causes the voltage drop across the stator resistance R_{Stator} and the synchronous reactance X_s (see Figure 17) to increase instantaneously, which in turn causes the generator voltage $E_{Gen.}$ to decrease instantaneously. Since the generator voltage $E_{Gen.}$ decreases, the amount of active power $P_{Gen.}$ which the generator supplies to the load decreases slightly (and also instantaneously).

The slight decrease in the generator active power $P_{Gen.}$ following an increase in the inductive load causes the generator torque $T_{Gen.}$ to decrease slightly and instantaneously. Since torque $T_{Gen.}$ opposes the torque applied by the hydraulic turbine to the synchronous generator shaft, this causes the generator speed $n_{gen.}$ to increase. However, due to the high inertia of the hydraulic turbine driving each synchronous generator in a hydropower plant, the generator speed $n_{gen.}$ (and, consequently, the generator frequency $f_{gen.}$) does not increase instantaneously when the inductive load connected to the generator increases. Therefore, since the generator torque $T_{Gen.}$ decreases slightly and the generator speed $n_{gen.}$ remains constant, the mechanical power P_M at the generator shaft decreases slightly when the inductive load connected to the generator increases.

In brief, all of the synchronous generator parameters shown in Figure 20 and Figure 21 except the generator speed $n_{Gen.}$ vary instantaneously when the value of the inductive load connected to the generator changes.

After the increase in the inductive load, the generator speed $n_{Gen.}$ (and, consequently, the generator frequency $f_{Gen.}$) begins to increase slightly. The rate at which the generator speed $n_{Gen.}$ increases depends on the inertia of the hydraulic turbine and on the magnitude of the increase in the inductive load. The higher the inertia of the hydraulic turbine and the smaller the magnitude of the increase in the inductive load, the slower the generator speed $n_{Gen.}$ increases. Conversely, the lower the inertia of the hydraulic turbine and the greater the magnitude of the increase in the inductive load, the faster the generator speed $n_{Gen.}$ increases.

As the generator speed $n_{Gen.}$ slightly increases after the increase in the inductive load, the other generator parameters also vary. The increase in the generator speed $n_{Gen.}$ causes the generator voltage $E_{Gen.}$ to increase a little, thereby slightly increasing the generator current $I_{Gen.}$, active power $P_{Gen.}$, and reactive power $Q_{Gen.}$. As the generator active power $P_{Gen.}$ increases slightly, the generator torque $T_{Gen.}$ also increases slightly. Since both the generator speed $n_{Gen.}$ and torque $T_{Gen.}$ increase, the mechanical power P_M at the generator shaft also increases slightly. When the generator counteracting torque $T_{Gen.}$ once again becomes equal to the torque applied by the hydraulic turbine to the synchronous generator shaft, the generator speed $n_{Gen.}$, as well as the other generator parameters, stabilize at a new operating point. The new steady-state values of the synchronous generator parameters mainly depend on the magnitude of the increase in the inductive load.

When the inductive load connected to a turbine-driven synchronous generator decreases, the effects on the generator parameters described above are reversed. This means that, when the inductive load decreases, the generator current $I_{Gen.}$ and reactive power $Q_{Gen.}$ decrease instantaneously, the generator voltage $E_{Gen.}$ increases instantaneously, the generator active power $P_{Gen.}$, torque $T_{Gen.}$, and mechanical power P_M increase slightly and instantaneously, while the generator speed $n_{Gen.}$ (and thus the generator frequency $f_{Gen.}$) remains virtually constant. After the decrease in the inductive load, the generator speed $n_{Gen.}$ begins to decrease slightly. Therefore, the generator voltage $E_{Gen.}$, current $I_{Gen.}$, active power $P_{Gen.}$, reactive power $Q_{Gen.}$, torque $T_{Gen.}$, and mechanical power P_M also decrease slightly with the generator speed $n_{Gen.}$. When the generator torque $T_{Gen.}$ once again becomes equal to the torque applied by the hydraulic turbine to the synchronous generator shaft, the generator speed $n_{Gen.}$, as well as the other generator parameters, stabilize at a new operating point. The new steady-state values of the synchronous generator parameters mainly depend on the magnitude of the decrease in the inductive load.

Frequency control of a turbine-driven synchronous generator

The frequency of a synchronous generator is controlled by monitoring and regulating the generator speed. The regulation of the generator speed is achieved by varying the opening of the adjustable vanes determining the amount of water flowing in the hydraulic turbine.

Figure 22 shows the torque-speed and mechanical power-speed characteristics of a hydraulic turbine (i.e., a Francis turbine) for various openings of the adjustable vanes of the turbine. Increasing the vane opening increases the amount of water flowing through the turbine, thereby allowing the turbine to rotate at higher speeds, produce higher torques, and generate more mechanical power.

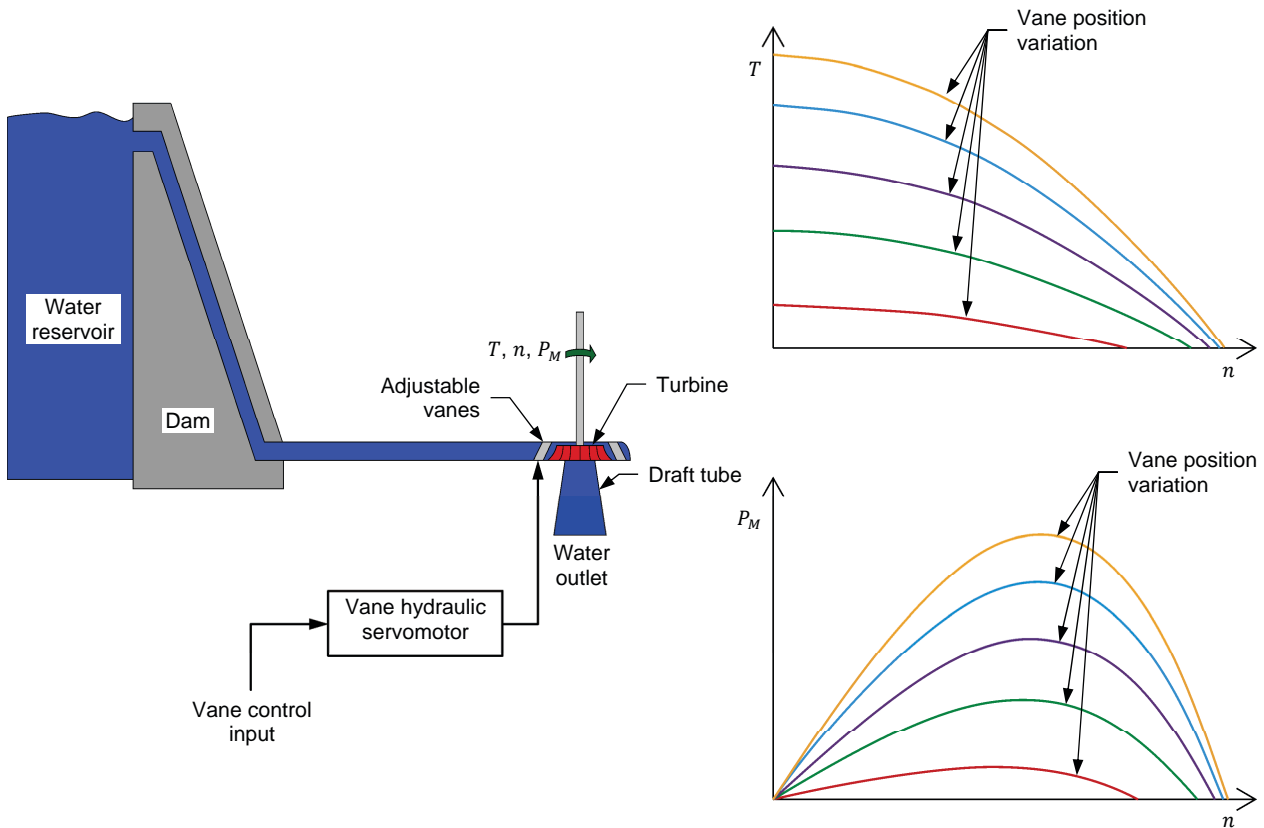

Figure 22. Torque-speed and mechanical power-speed characteristics of a hydraulic turbine (i.e., a Francis turbine) for various openings of the adjustable vanes of the turbine.

As explained earlier in this discussion, the rotation speed, and thus the frequency, of a turbine-driven synchronous generator decreases when the amount of active power which the generator supplies to the load increases (e.g., when the resistive load connected to the generator increases), and vice versa. To maintain the generator frequency constant, the amount of water flowing through the turbine must be continually adjusted (by changing the opening of the adjustable vanes) so that the amount of mechanical power produced by the turbine maintains the generator speed constant no matter what the active power demand is. For instance, when the active power demand increases, the vane opening is increased until the hydraulic turbine produces the exact amount of mechanical power required to maintain the generator speed constant. At this point, the amount of mechanical power produced by the hydraulic turbine has increased to the exact value required to match the active power demand of the load. Note that since the generator speed is maintained constant, the torque at the hydraulic turbine increases accordingly. This is illustrated in Figure 23.

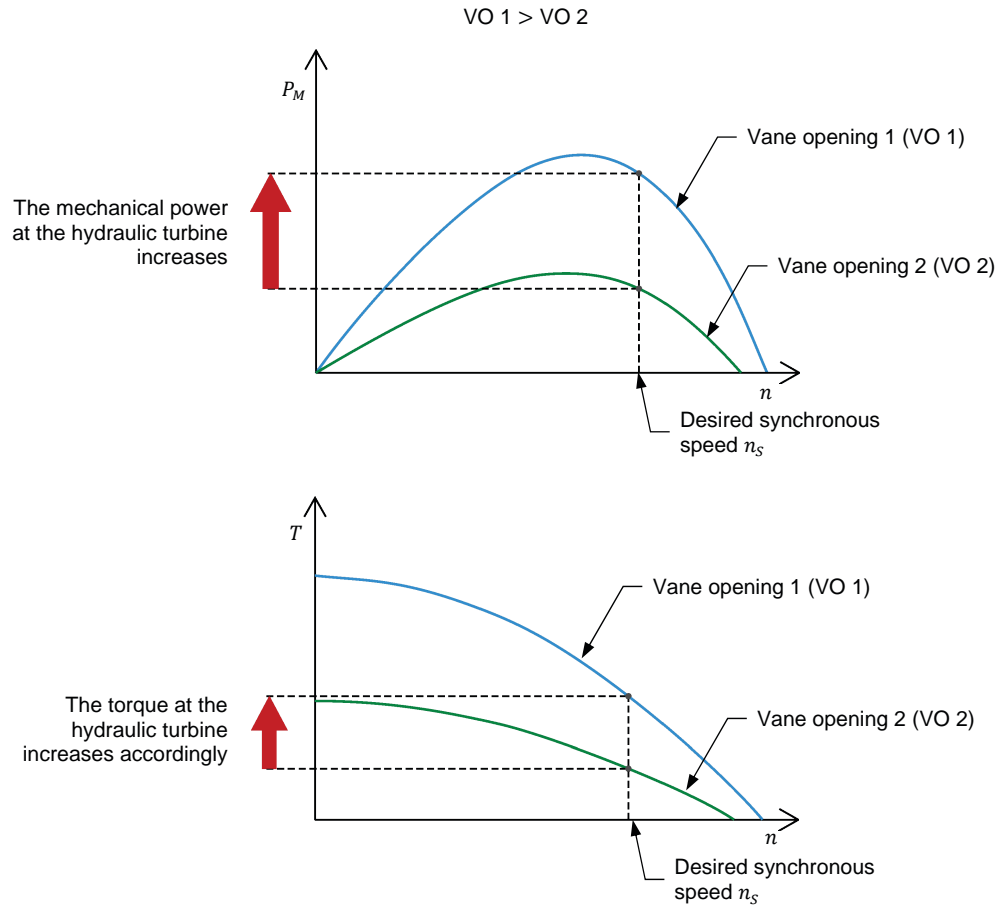

Figure 23. When the speed of a turbine-driven synchronous generator is maintained constant, increasing the opening of the adjustable vanes of the hydraulic turbine increases both the mechanical power and the torque at the hydraulic turbine.

The device which automatically adjusts the opening of the adjustable vanes in a turbine-driven synchronous generator (such as in a hydropower plant) to maintain the generator speed, and thus the generator frequency, constant is referred to as a speed governor. The operation of the speed governor is discussed later in this manual.

Voltage control of a synchronous generator

The magnitude of the voltage produced by a synchronous generator is proportional to both the generator speed and generator field current. However, it is not possible to use the generator speed in order to control the generator voltage because varying the generator speed also varies the generator frequency (the generator frequency is directly proportional to the generator speed). Therefore, only the generator field current can be used to control the voltage produced by a synchronous generator without modifying the generator speed and frequency. The higher the generator field current, the higher the generator voltage. Controlling (i.e., regulating) the voltage produced by a synchronous generator using the generator field current is commonly achieved by connecting an external three-phase ac power source and a thyristor three-phase bridge to the generator field winding, as shown in Figure 24.

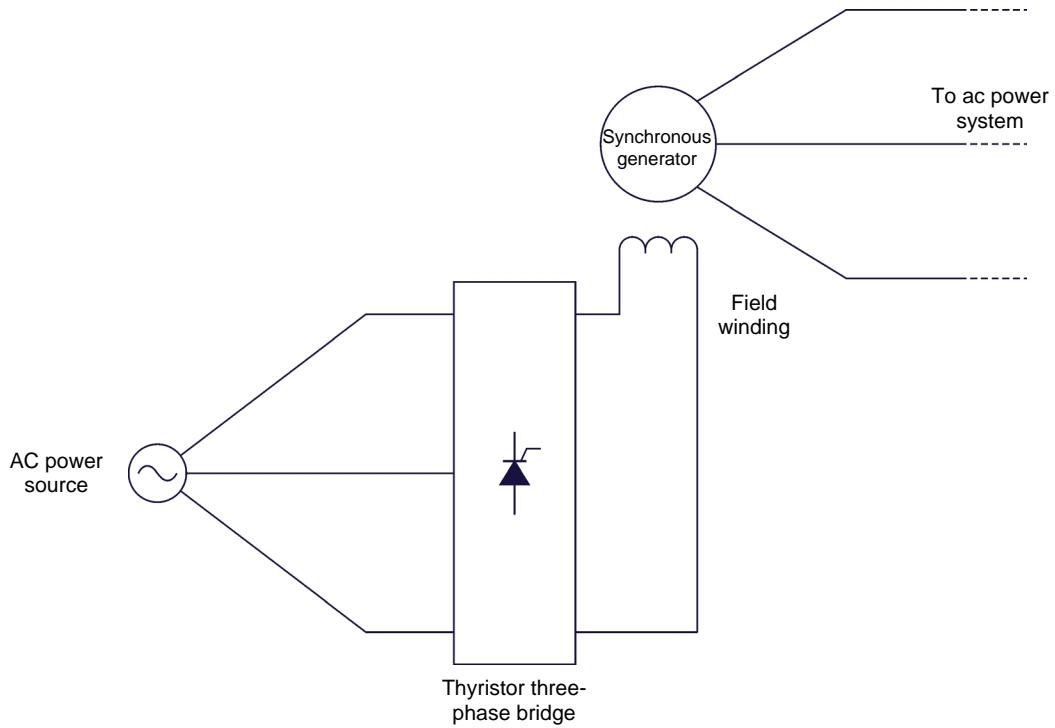

Figure 24. Synchronous generator whose field current is supplied by a three-phase ac power source connected to a thyristor three-phase bridge.

In Figure 24, the three-phase ac power source supplies power to the thyristor bridge. The thyristor bridge then converts the ac power into dc power, which is supplied to the generator field winding. Varying the firing angle of the thyristor three-phase bridge varies the voltage at the dc side of the bridge, and thus the magnitude of the current flowing through the field winding. The lower the firing angle of the thyristor bridge, the higher the voltage at the dc side of the bridge, and consequently, the higher the generator field current. Conversely, the higher the firing angle of the thyristor bridge, the lower the voltage at the dc side of the bridge, and consequently, the lower the generator field current.

In order to maintain the generator voltage constant, it is necessary to dynamically adjust the firing angle of the thyristor bridge to adjust the magnitude of the generator field current so that the resulting increase or decrease in the generator voltage fully compensates for the voltage fluctuations due to changes in the load value.

The device which automatically adjusts the field current of a synchronous generator (such as in a hydropower plant) to maintain the generator voltage constant is referred to as an automatic voltage regulator (AVR). The operation of the AVR is discussed later in this manual.

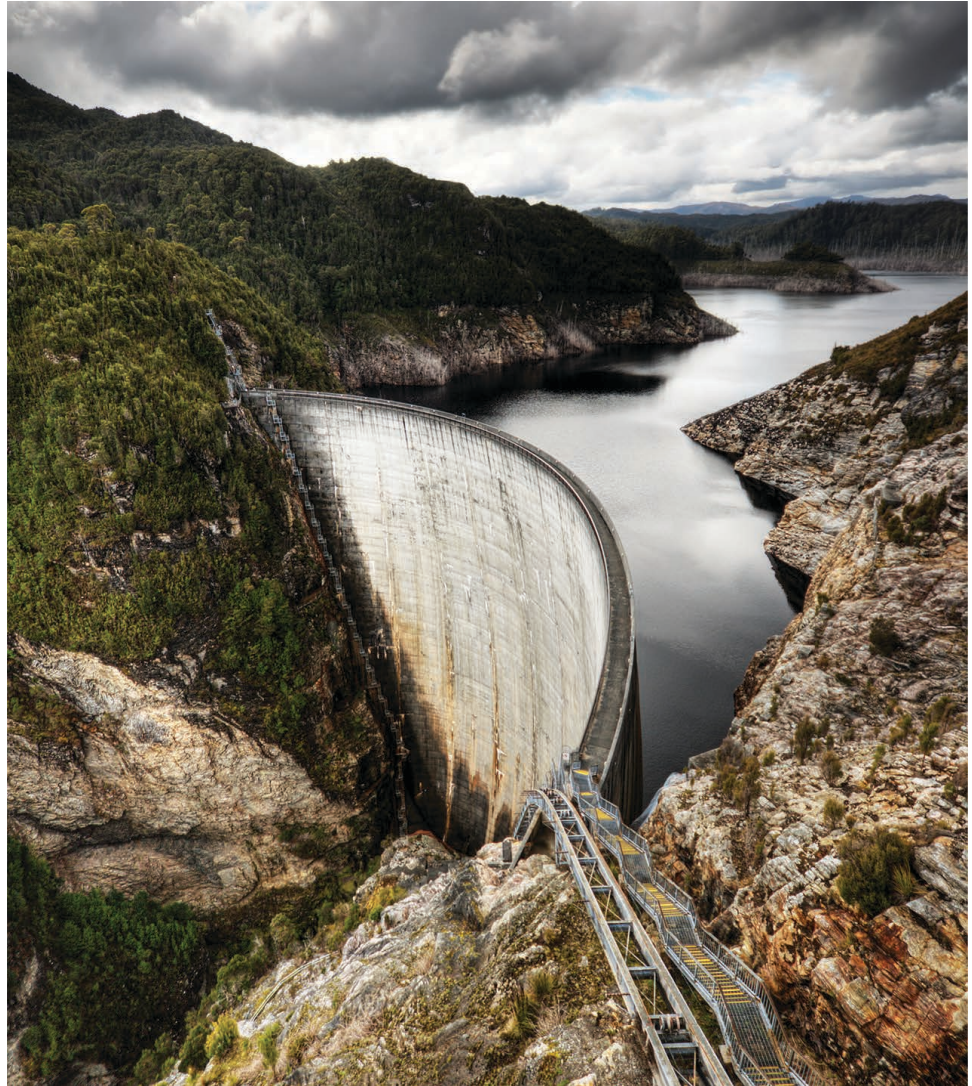

Figure 25. Due to the availability of water and the large quantities of electricity generated using hydropower, hydroelectricity is produced in over 150 countries in the world. The above figure shows the Gordon Dam in Tasmania, Australia (photo courtesy of JJ Harrison).

Auto-excited brushless synchronous generators

Supplying field current to a synchronous generator using a three-phase ac power source and a thyristor three-phase bridge as described in the previous section (see Figure 24) presents disadvantages. Firstly, it requires an external power source to supply three-phase ac power. In many cases, such as when the ac power network is blacked out, no external ac power source is available. Secondly, since dc power has to be supplied to the generator field winding which is wound on the rotor of the generator, it is necessary for the generator to be fitted with brushes on the stator and slip rings on the rotor shaft. This is inconvenient, as brushes tend to wear off with use and therefore require maintenance.

To solve these problems (i.e., the need for an external ac power source, brushes, and slip rings, and the wear of the brushes), a special type of synchronous generator, called auto-excited brushless synchronous generator, has been developed. Figure 26 shows the simplified equivalent diagram of an auto-excited brushless synchronous generator.

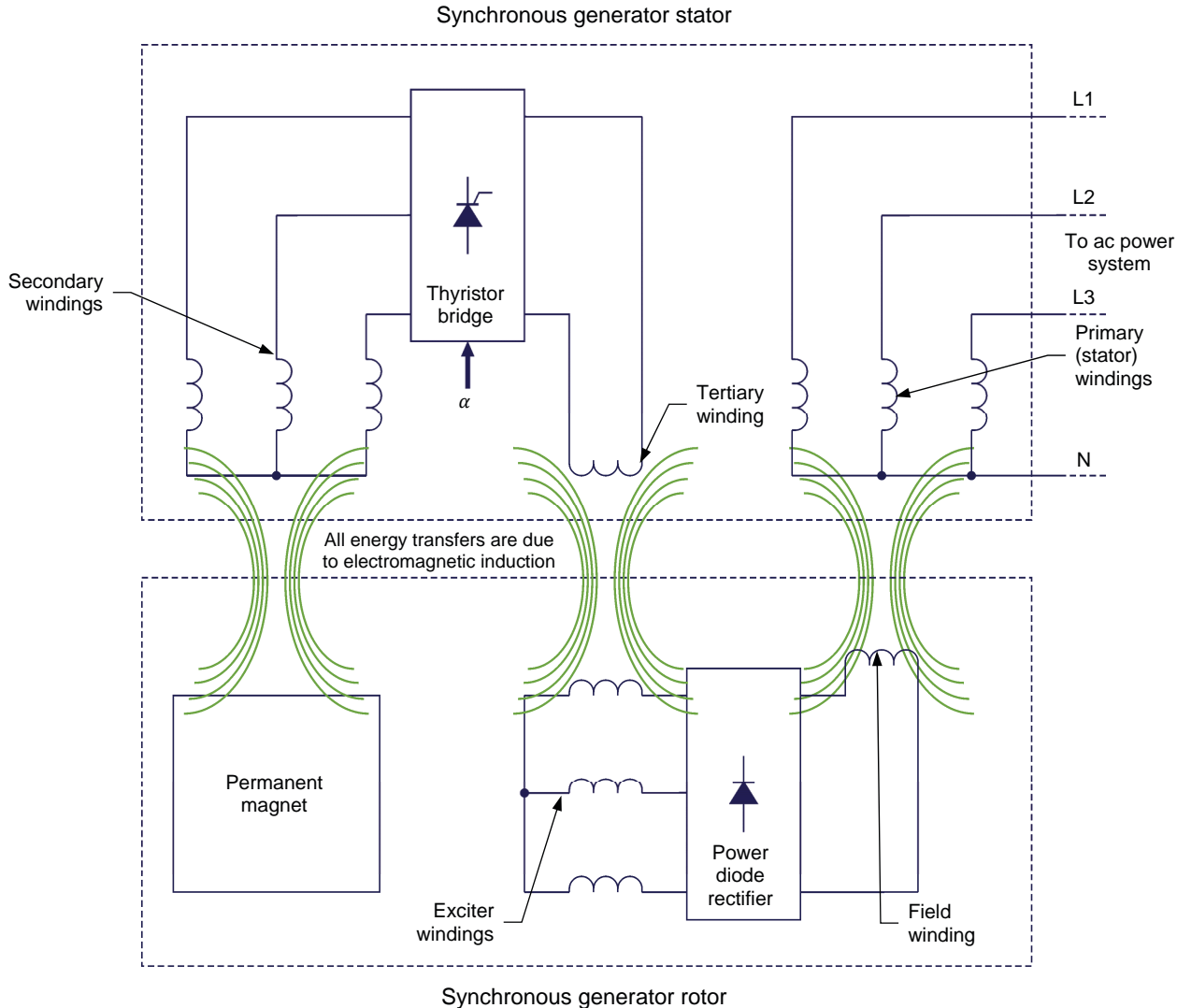

Figure 26. Simplified equivalent diagram of an auto-excited brushless synchronous generator.

In an auto-excited brushless synchronous generator, a permanent magnet is installed in the rotor of the synchronous generator. When a prime mover (e.g., a hydraulic turbine) makes the rotor of the synchronous generator rotate, the permanent magnet in the rotor also rotates, inducing ac voltage across the three-phase secondary windings located at the stator. The ac voltage across the secondary windings is then converted into dc voltage by a thyristor three-phase bridge. Adjusting the firing angle α of the thyristor bridge varies the value of the voltage at the dc side of the bridge, and thus the value of the dc current flowing through the tertiary winding of the generator located at the stator. The current flowing through the tertiary winding produces a magnetic field that induces three-phase ac voltage across the three-phase exciter windings located at the rotor. The ac voltage induced across the exciter windings is converted by a

power diode three-phase rectifier into dc voltage which causes dc current to flow through the field winding of the generator. Finally, the dc current flowing through the generator field winding induces ac voltage across the generator primary windings (i.e., the stator windings) located at the stator, just as in any synchronous generator.

Consequently, auto-excited brushless synchronous generators have no need for an exterior three-phase ac power source. The dc current flowing through the field winding originates from ac voltage induced across the three-phase secondary windings by the rotation of the permanent magnet in the generator rotor. The magnitude of the generator field current is adjusted by varying the firing angle of the thyristor bridge supplying dc current to the generator tertiary winding. Because of this, auto-excited brushless synchronous generators can be started without the need for an external power source. This is especially important in generating stations when all grid-powered ac power sources are offline and thus cannot be used for generator excitation.

Auto-excited brushless synchronous generators also have no need for brushes or slip rings, since no electrical part of the rotor needs to be physically connected to the stator. All energy transfers between the stator and the rotor are achieved through electromagnetic induction. Because of this, auto-excited brushless synchronous generators require much less maintenance than common synchronous generators. This is an important advantage in hydropower plants, in which the synchronous generators are generally very large, thereby making maintenance of the brushes and slip rings difficult and costly.



Figure 27. The Itaipu Dam is located on the Paraná River, at the border between Brazil and Paraguay. With an installed capacity of 14 000 MW, it is one of the world's largest capacity hydropower plants.

PROCEDURE OUTLINE

The Procedure is divided into the following sections:

- Set up and connections
- Generator frequency and voltage manual control
- Log of generator frequency and voltage in manual generator operation

PROCEDURE



High voltages are present in this laboratory exercise. Do not make or modify any banana jack connections with the power on unless otherwise specified.

Set up and connections

In this section, you will set up a synchronous generator driven by a hydraulic turbine and connected to a three-phase resistive-inductive load through a three-phase contactor. You will then set up the measuring equipment required to study the manual control of the generator frequency and voltage.

1. Refer to the Equipment Utilization Chart in Appendix A to obtain the list of equipment required to perform this exercise.

Install the required equipment in the *Workstation*.



Before coupling rotating machines, make absolutely sure that power is turned off to prevent any machine from starting inadvertently.

Mechanically couple the *Synchronous Motor/Generator* to the *Four-Quadrant Dynamometer/Power Supply* using a timing belt.

2. Make sure the ac and dc power switches on the *Power Supply* are set to the O (off) position, then connect the *Power Supply* to a three-phase ac power outlet.

Make sure the main power switch on the *Four-Quadrant Dynamometer/Power Supply* is set to the O (off) position, then connect its *Power Input* to an ac power outlet.

Connect the *Power Input* of the *Data Acquisition and Control Interface* to a 24 V ac power supply.

Connect the *Low Power Input* of the *Power Thyristors* module to the *Power Input* of the *Data Acquisition and Control Interface*. Turn the 24 V ac power supply on.

3. Connect the USB port of the *Data Acquisition and Control Interface* to a USB port of the host computer.

Connect the USB port of the *Four-Quadrant Dynamometer/Power Supply* to a USB port of the host computer.

4. Turn the *Four-Quadrant Dynamometer/Power Supply* on, then set the *Operating Mode* switch to *Dynamometer*.

5. Turn the host computer on, then start the *LVDAC-EMS* software.

In the *LVDAC-EMS Start-Up* window, make sure the *Data Acquisition and Control Interface* and the *Four-Quadrant Dynamometer/Power Supply* are detected. Make sure the *Computer-Based Instrumentation* and *Synchronous Generator Control* functions are available for the *Data Acquisition and Control Interface* module. Make sure that the *Turbine Emulator* function is available for the *Four-Quadrant Dynamometer/Power Supply*. Also, select the network voltage and frequency that correspond to the voltage and frequency of the local ac power network, then click the *OK* button to close the *LVDAC-EMS Start-Up* window.

6. Connect the equipment as shown in Figure 28. Use the **Four-Quadrant Dynamometer/Power Supply** and the **Power Supply** to implement the hydraulic-turbine emulator and the three-phase ac power source, respectively. Also, use the **Power Thyristors** module to implement the thyristor three-phase bridge.

When connecting the thyristor three-phase bridge, make sure switches S_1 and S_2 on the **Power Thyristors** module are set to the I (closed) position. Doing so connects thyristors Q_1 to Q_6 in a three-phase bridge configuration.



In the circuit of Figure 28, inputs E2, E3, E4, I3, and I4 are used to measure the circuit parameters necessary for controlling the synchronous generator when it is connected to a dead bus (dead bus operation of synchronous generators is covered in detail in Exercise 2). Because of this, inputs E2, E3, E4, I3, and I4 cannot be used for circuit parameter measurement and observation in this exercise.

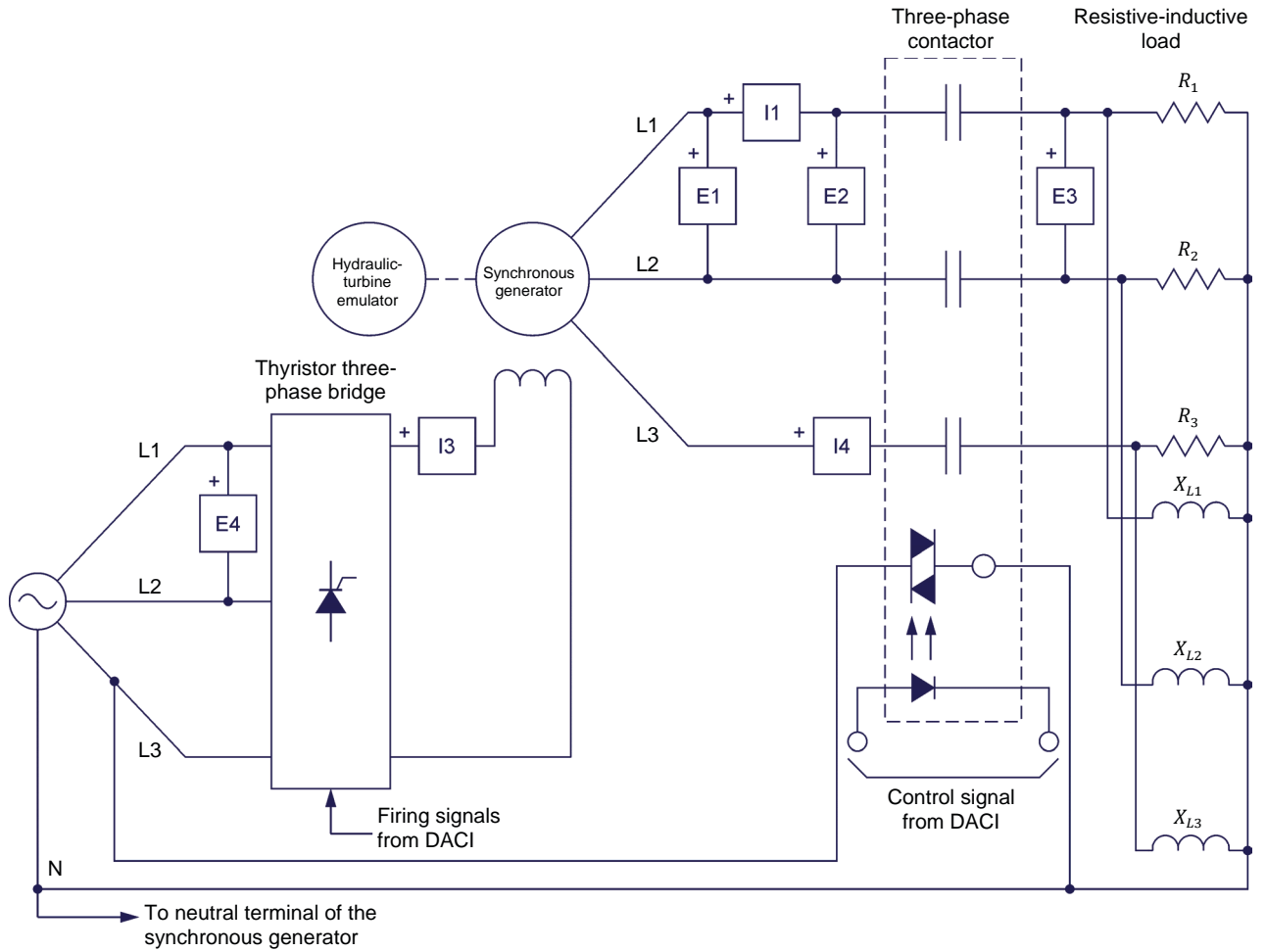

| Local ac power network | | R_1, R_2, R_3 (Ω) | X_{L1}, X_{L2}, X_{L3} (Ω) |
|------------------------|-------------------|---------------------------------|--|
| Voltage (V) | Frequency (Hz) | | |
| 120 | 60 | 600 | 600 |
| 220 | 50 | 2200 | 2200 |
| 240 | 50 | 2400 | 2400 |
| 220 | 60 | 2200 | 2200 |

Figure 28. Turbine-driven synchronous generator connected to a three-phase resistive-inductive load through a three-phase contactor.

7. Make the necessary switch settings on the **Resistive Load** and on the **Inductive Load** so that the resistance and reactance of the three-phase resistive-inductive load are equal to the values indicated in the table of Figure 28.



The values of the resistive load and inductive load used in the circuits of this manual depend on the local ac power network voltage and frequency. Whenever necessary, a table below the circuit diagram indicates the value of each component for ac power network voltages of 120 V, 220 V, and 240 V, and for ac power network frequencies of 50 Hz and 60 Hz. Make sure to use the component values corresponding to the local ac power network voltage and frequency.



Appendix C lists the switch settings required on the **Resistive Load**, the **Inductive Load**, and the **Capacitive Load** in order to obtain various resistance (or reactance) values.

8. Make sure the **Sync.** switch on the **Synchronizing Module/Three-Phase Contactor** is set to the **O** position. This allows remote control of the three-phase contactor by the **Data Acquisition and Control Interface** module.
9. Connect the **Digital Outputs** of the **Data Acquisition and Control Interface** to the **Firing Control Inputs** of the **Power Thyristors** module using the provided cable with DB9 connectors. This connection provides the signals that control the thyristor firing in the **Power Thyristors** module. The firing control signals are provided by the **Data Acquisition and Control Interface** and controlled in the **Synchronous Generator Control** window of the **LVDAC-EMS** software.
10. Connect **Digital Output 1 (DO1)** of the **Data Acquisition and Control Interface** to the positive (+) terminal of the **Remote Control** input on the **Synchronizing Module/Three-Phase Contactor** using a miniature banana plug lead. Connect a digital (D) common (white terminal) of the **Data Acquisition and Control Interface** to the negative (-) terminal of the **Remote Control** input on the **Synchronizing Module/Three-Phase Contactor** using a miniature banana plug lead.
11. In **LVDAC-EMS**, open the **Synchronous Generator Control** window, then make the following settings:
 - Make sure the **Function** parameter is set to **Hydropower Generator (Dead Bus – Balanced Load)**. This function allows control of a turbine-driven synchronous generator connected to a dead bus whose load is balanced (i.e., the three-phase resistive-inductive load in the diagram of Figure 28). The function includes a synchro-check relay used to control the connection of the generator to the dead bus. The connection of a synchronous generator to a dead bus is covered in detail in Exercise 2.



The generator speed governor and automatic voltage regulator are not used in this exercise. Do not take into account the blocks, signals, inputs, and outputs related to the speed governor and automatic voltage regulator in the block diagram of the *Hydropower Generator (Dead Bus – Balanced Load)* function. The speed governor and automatic voltage regulator are covered in detail in Exercise 3.

- Make sure the *Hydropower Generator (Dead Bus – Balanced Load)* function is set to *Stopped* (i.e., make sure the *Status* parameter is set to *Stopped*).

Automatic Voltage Regulator (AVR):

- Set the *Thyristor Bridge Firing Control Mode* parameter to *Manual*. This control mode enables manual control of the firing angle of the thyristor bridge using the *Thyristor Bridge Firing Angle α* parameter or the *Thyristor Bridge Firing Angle* knob at the bottom of the *Synchronous Generator Control* window.
- Make sure the *Thyristor Bridge Firing Angle α* parameter is set to 70°. This sets the firing angle of the thyristor bridge to 70°.



Do not modify the other parameters in the *Synchronous Generator Control* window (i.e., leave these parameters to the default values). The use of these parameters is covered in detail in the following exercises.

12. In *LVDAC-EMS*, open the *Four-Quadrant Dynamometer/Power Supply* window, then make the following settings:

- Set the *Function* parameter to *Hydraulic-Turbine Emulator*. This setting makes the *Four-Quadrant Dynamometer/Power Supply* operate as a prime mover emulating water flowing through a hydraulic turbine and causes it to rotate. Therefore, the prime mover's torque-versus-speed characteristic is the same as the torque-versus-speed characteristic that would be obtained at the hydraulic turbine shaft for different vane positions (i.e., for different water flow rates). In other words, the generator mechanically coupled to the *Four-Quadrant Dynamometer/Power Supply* operates as if it were driven by water flowing through the turbine, but without the need for water or the turbine.
- Make sure the *Vane Control* parameter is set to *Slider*. This enables the vane opening of the hydraulic-turbine emulator to be controlled using the *Vane Hydraulic Servomotor Control* slider at the bottom of the *Four-Quadrant Dynamometer/Power Supply* window.
- Make sure the *Turbine Type* parameter is set to *300 W, Francis*. This makes the hydraulic-turbine emulator operate as a 300 W Francis turbine.
- Set the *Vane Maximal Speed* parameter to 10.0%/s. This sets the maximal speed at which the vane of the hydraulic-turbine emulator can open or close to 10%/s.

- Make sure the *Runner Inertia* parameter is set to 0.3 kg·m². This sets the runner inertia of the hydraulic-turbine emulator to 0.3 kg·m². The higher the runner inertia of the hydraulic-turbine emulator, the slower the turbine speed increases as water flow increases, and the slower the turbine speed decreases as water flow decreases.
- Make sure the *Hydraulic-Turbine Emulator* function is set to *Stopped*.



The *Pulley Ratio* parameter is grayed out since it is automatically set to the required value (24:24).

13. In LVDAC-EMS, open the *Metering* window. Make the required settings in order to measure the rms value (ac) of the synchronous generator current $I_{Gen.}$ (input *I1*). Also, set two meters to measure the three-phase active power $P_{Gen.}$ [metering function *PQS1 (E1, I1) 3~*] which the synchronous generator supplies to the load and the three-phase reactive power $Q_{Gen.}$ [metering function *PQS1 (E1, I1) 3~*] which the synchronous generator exchanges with the load.
14. On the *Synchronous Motor/Generator*, set the *Exciter* switch to the closed position (I), then turn the *Exciter* knob fully clockwise (i.e., set it to the *Max.* position). This ensures that the resistance of the generator exciter circuit is at a minimum.

Generator frequency and voltage manual control

In this section, you will start the hydraulic-turbine emulator. You will adjust the generator frequency and voltage to their nominal values by varying the vane opening of the hydraulic turbine and the firing angle of the thyristor three-phase bridge. You will first change the resistance and then the reactance of the three-phase resistive-inductive load connected to the synchronous generator, and observe the effects of each change on the generator frequency, voltage, and speed. For each load change, you will readjust the generator frequency and voltage to their nominal values. Using your observations, you will determine how it is possible to maintain the generator frequency and voltage constant as the load varies. Finally, you will determine if manually adjusting the generator frequency and voltage after load variations is fast, precise, and convenient.

15. On the *Power Supply*, turn the three-phase ac power source on.

In the *Four-Quadrant Dynamometer/Power Supply* window, start the hydraulic-turbine emulator by clicking the *Start/Stop* button or by setting the *Status* parameter to *Started*.

In the *Synchronous Generator Control* window, start the hydropower generator by clicking the *Start/Stop* button or by setting the *Status* parameter to *Started*. Also, set the *Relay Output* parameter to *High* to make the three-phase contactor close, thereby connecting the synchronous generator to the dead bus (i.e., the three-phase resistive-inductive load).

16. In the **Four-Quadrant Dynamometer/Power Supply** window, adjust the vane opening (indicated by the **Vane Opening** meter at the bottom of the window) of the hydraulic-turbine emulator using the **Vane Hydraulic Servomotor Control** slider so that the generator frequency $f_{Gen.}$ (indicated by the **Generator Frequency** meter at the bottom of the **Synchronous Generator Control** window) is as close as possible to the local ac power network frequency.



Actual Francis turbines generally yield their nominal (maximal) power when the vanes directing water to the turbine runner are at an angle of about 25° around their axis. Thus, in the hydraulic-turbine emulator, a vane opening of 100% corresponds to a vane angle of 25° in actual Francis turbines. On the other hand, a vane opening of 0% corresponds to a vane angle of 0° (i.e., the turbine vanes are closed).

17. In the **Synchronous Generator Control** window, adjust the **Thyristor Bridge Firing Angle α** parameter so that the generator voltage $E_{Gen.}$ (indicated by the **Generator Voltage** meter at the bottom of the window) is as close as possible to the local ac power network voltage. While doing so, observe the generator field current I_F (indicated by the **Field Current** meter at the bottom of the **Synchronous Generator Control** window).

18. What happens to the field current I_F of the synchronous generator as you adjust the firing angle α of the thyristor bridge?

The field current I_F of the synchronous generator varies with the firing angle α of the thyristor bridge. Decreasing the firing angle α of the thyristor bridge increases the voltage at the dc side of the thyristor bridge and thus the generator field current I_F . Conversely, increasing the firing angle α decreases the generator field current I_F .

19. Let the hydropower generator operate about 5 minutes to ensure proper warm up of the system. If necessary, in the **Four-Quadrant Dynamometer/Power Supply** and **Synchronous Generator Control** windows, adjust the vane opening of the hydraulic-turbine emulator using the **Vane Hydraulic Servomotor Control** slider, and the generator field current I_F using the **Thyristor Bridge Firing Angle α** parameter so that the generator frequency $f_{Gen.}$ and voltage $E_{Gen.}$ remain equal to the nominal values.



This step ensures that the friction compensation calibration that will be done in the next step is optimal.

20. In the **Four-Quadrant Dynamometer/Power Supply** window, close the vane completely using the **Vane Hydraulic Servomotor Control** slider. In the **Synchronous Generator Control** window, adjust the **Thyristor Bridge Firing Angle α** parameter so that the generator field current is minimal. Wait for the hydraulic turbine driving the generator to stop rotating, then stop the hydraulic-turbine emulator by clicking the **Start/Stop** button or by setting the **Status** parameter to **Stopped**.

In the *Synchronous Generator Control* window, set the *Relay Output* parameter to *Low* to make the three-phase contactor open, thereby disconnecting the synchronous generator from the dead bus (i.e., the three-phase resistive-inductive load).

On the *Synchronous Motor/Generator*, set the *Exciter* switch to the open position (O).

21. In the *Tools* menu of the *Four-Quadrant Dynamometer/Power Supply* window, select *Friction Compensation Calibration*. This brings up the *Friction Compensation Calibration* dialog box. Click *OK* in this box to start the calibration process. Observe that the prime mover starts to rotate at high speed, thereby driving the shaft of the *Synchronous Motor/Generator*. The prime mover speed is then automatically decreased by steps to perform the calibration process. Once the calibration process is completed (which takes a few minutes), the prime mover stops rotating, then the *Friction Compensation Calibration* dialog box indicates that the calibration process is finished. Click *OK* in the *Friction Compensation Calibration* dialog box to close this box. Restart the *Four-Quadrant Dynamometer/Power Supply* to apply the changes (i.e., the newly calibrated friction compensation curve) by setting the main power switch of this module to O (off), and then I (on).

22. In the *Four-Quadrant Dynamometer/Power Supply* window, make the following settings:

- Set the *Function* parameter to *Hydraulic-Turbine Emulator*.
- Make sure the *Vane Control* parameter is set to *Slider*.
- Make sure the *Turbine Type* parameter is set to *300 W, Francis*.
- Set the *Vane Maximal Speed* parameter to 10.0%/s.
- Make sure the *Runner Inertia* parameter is set to 0.3 kg·m².
- Make sure the *Hydraulic-Turbine Emulator* function is set to *Stopped*.

23. In the *Synchronous Generator Control* window, set the *Relay Output* parameter to *High* to make the three-phase contactor close, thereby reconnecting the synchronous generator to the dead bus (i.e., the three-phase resistive-inductive load).

On the *Synchronous Motor/Generator*, set the *Exciter* switch to the closed position (I).

24. In the *Four-Quadrant Dynamometer/Power Supply* window, start the hydraulic-turbine emulator by clicking the *Start/Stop* button or by setting the *Status* parameter to *Started*. Adjust the vane opening of the hydraulic-turbine emulator using the *Vane Hydraulic Servomotor Control* slider so that the generator frequency $f_{Gen.}$ is as close as possible to the local ac power network frequency.

25. In the *Synchronous Generator Control* window, adjust the *Thyristor Bridge Firing Angle α* parameter so that the generator voltage $E_{Gen.}$ is as close as possible to the local ac power network voltage.
26. If necessary, in the *Four-Quadrant Dynamometer/Power Supply* and *Synchronous Generator Control* windows, adjust the vane opening of the hydraulic-turbine emulator using the *Vane Hydraulic Servomotor Control* slider, and the generator field current I_F using the *Thyristor Bridge Firing Angle α* parameter so that the generator frequency $f_{Gen.}$ and voltage $E_{Gen.}$ remain equal to the nominal values.
27. In the *Generator Control*, *Metering*, and *Four-Quadrant Dynamometer/Power Supply* windows, measure the various parameters of the synchronous generator when the generator frequency $f_{Gen.}$ and voltage $E_{Gen.}$ are set to the nominal values. Record the values below.

Generator frequency $f_{Gen.} =$ _____ Hz

Generator voltage $E_{Gen.} =$ _____ V

Generator current $I_{Gen.} =$ _____ A

Generator active power $P_{Gen.} =$ _____ W

Generator reactive power $Q_{Gen.} =$ _____ var

Generator field current $I_F =$ _____ A

Thyristor bridge firing angle $\alpha =$ _____ °

Generator speed $n_{Gen.} =$ _____ r/min

Generator torque $T_{Gen.} =$ _____ N·m or lbf·in

Generator mechanical power $P_M =$ _____ W

Hydraulic-turbine vane opening = _____ %

Generator frequency $f_{Gen.} = 60.0$ Hz

Generator voltage $E_{Gen.} = 208$ V

Generator current $I_{Gen.} = 0.297$ A

Generator active power $P_{Gen.} = 82.2$ W

Generator reactive power $Q_{Gen.} = 68.3$ var

Generator field current $I_F = 0.70$ A

Thyristor bridge firing angle $\alpha = 70.2^\circ$

Generator speed $n_{Gen.} = 1800$ r/min

Generator torque $T_{Gen.} = -0.52$ N·m

Generator mechanical power $P_M = -97.3$ W

Hydraulic-turbine vane opening = 36.4 %

- 28.** In LVDAC-EMS, open the [Data Table](#) window. Set the timer to make 65 records with an interval of 1 second between each record. This corresponds to a data recording period of a little more than one minute.

Set the [Data Table](#) to record:

- the synchronous generator speed $n_{Gen.}$, torque $T_{Gen.}$, and mechanical power P_M indicated in the [Four-Quadrant Dynamometer/Power Supply](#) window;
- the synchronous generator voltage $E_{Gen.}$ indicated in the [Synchronous Generator Control](#) window;
- the synchronous generator current $I_{Gen.}$, three-phase active power $P_{Gen.}$, and three-phase reactive power $Q_{Gen.}$ indicated in the [Metering](#) window;
- the time associated with each record.

29. In the **Data Table**, start the timer to start data recording. Then, on the **Resistive Load** module, decrease the resistance of the three-phase load to the value indicated in Table 1. As you do so, observe what happens to the generator parameters.



*For optimal results, modify the switch settings simultaneously on the three legs of the **Resistive Load** and **Inductive Load** in order to avoid operation with an unbalanced load as much as possible.*

Table 1. Resistance value to be used for the three-phase resistive load in Figure 28.

| Local ac power network | | R_1, R_2, R_3 (Ω) |
|------------------------|-------------------|---------------------------------|
| Voltage (V) | Frequency (Hz) | |
| 120 | 60 | 400 |
| 220 | 50 | 1467 |
| 240 | 50 | 1600 |
| 220 | 60 | 1467 |

30. Wait for the timer in the **Data Table** to stop data recording. Then, save the recorded data.
31. Using the data you recorded, plot graphs of the synchronous generator speed $n_{Gen.}$, voltage $E_{Gen.}$, current $I_{Gen.}$, active power $P_{Gen.}$, reactive power $Q_{Gen.}$, torque $T_{Gen.}$, and mechanical power P_M as a function of time when the resistive load connected to the generator increases.

The resulting graphs of the synchronous generator speed $n_{Gen.}$, voltage $E_{Gen.}$, current $I_{Gen.}$, active power $P_{Gen.}$, reactive power $Q_{Gen.}$, torque $T_{Gen.}$, and mechanical power P_M as a function of time when the resistive load connected to the generator increases are presented below.

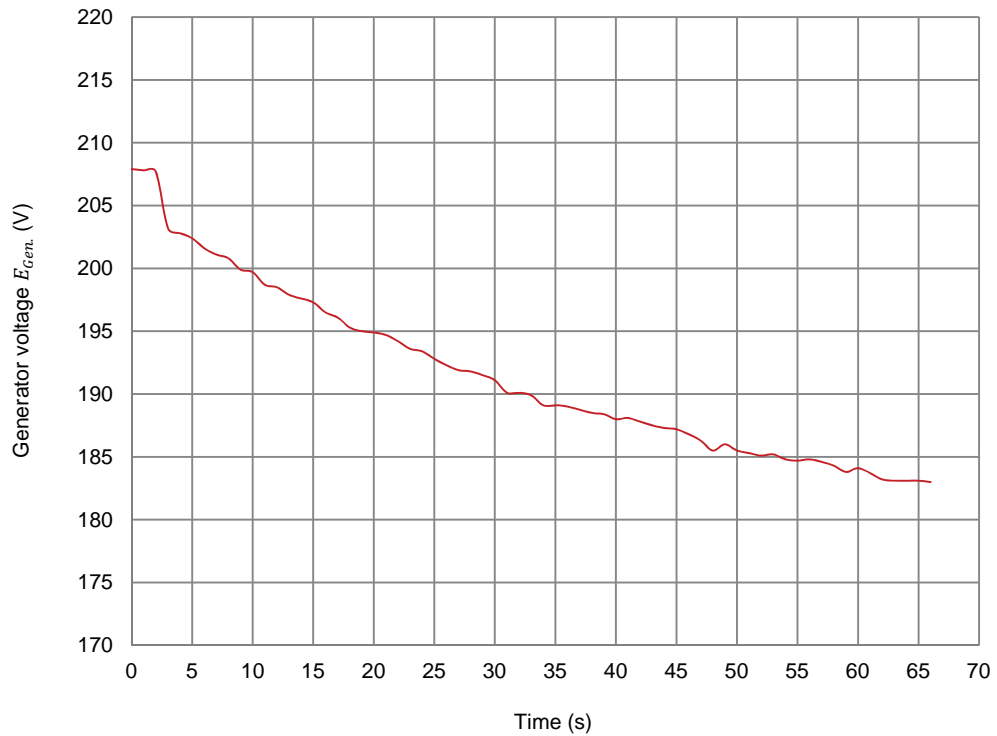
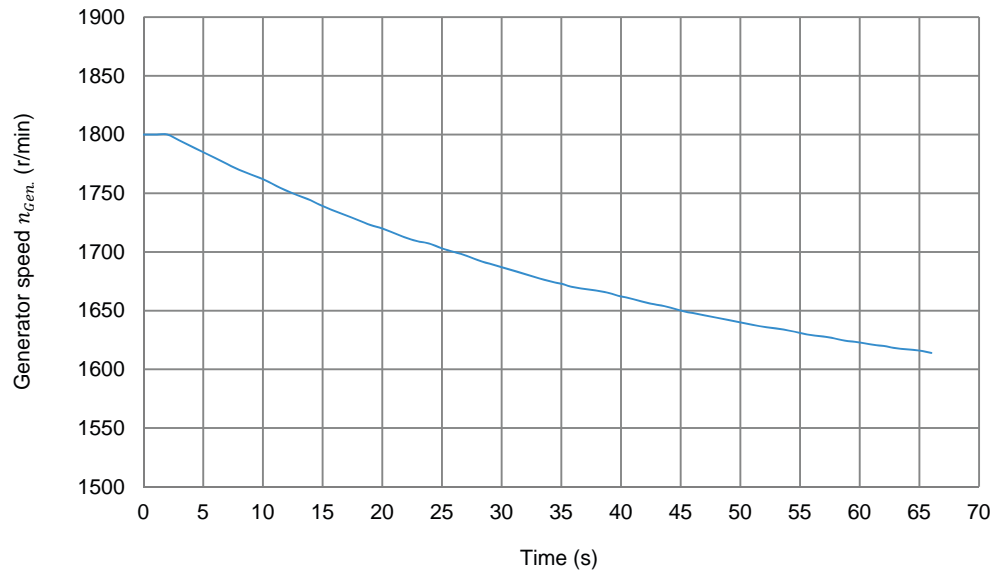

Graphs of the synchronous generator parameters as a function of time when the resistive load connected to the generator increases (part 1).

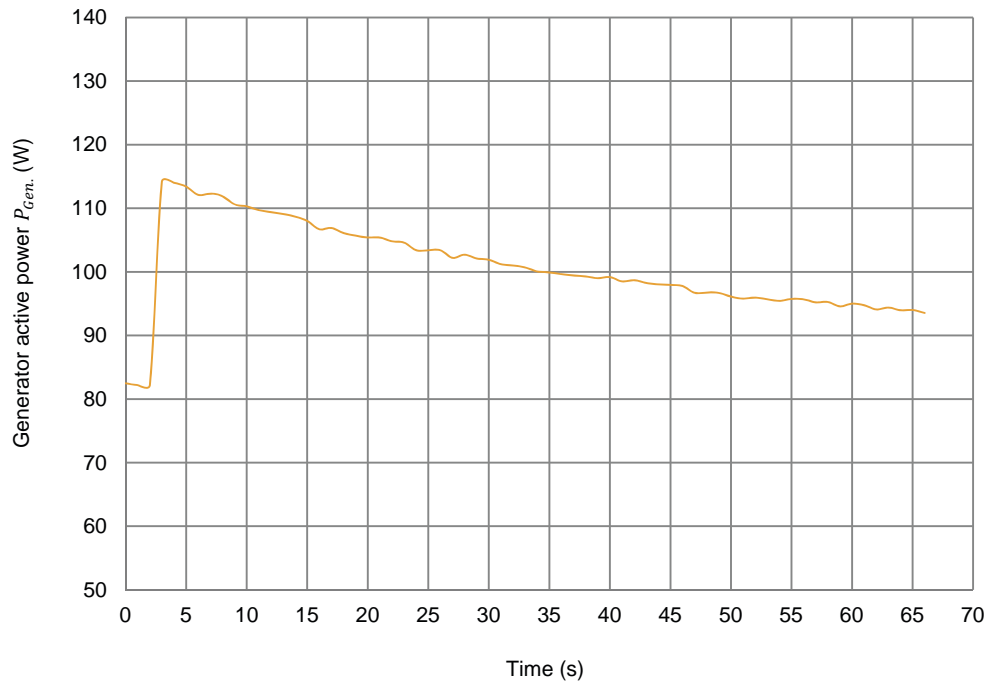
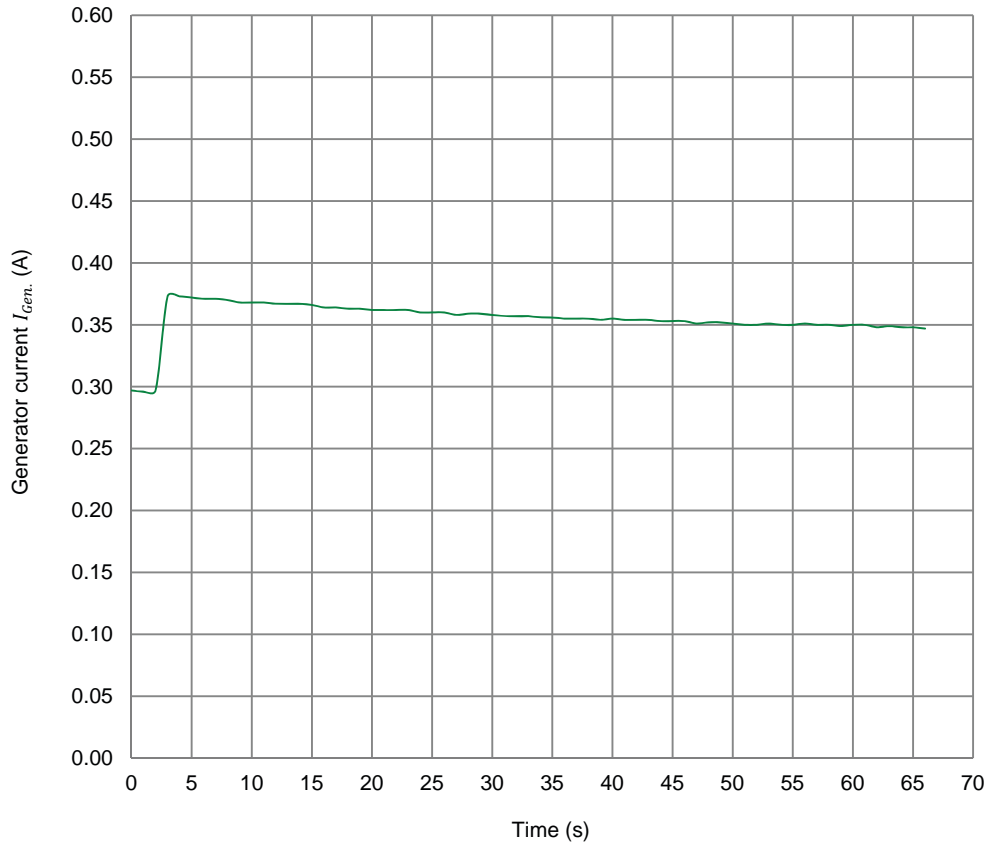

Graphs of the synchronous generator parameters as a function of time when the resistive load connected to the generator increases (part 2).

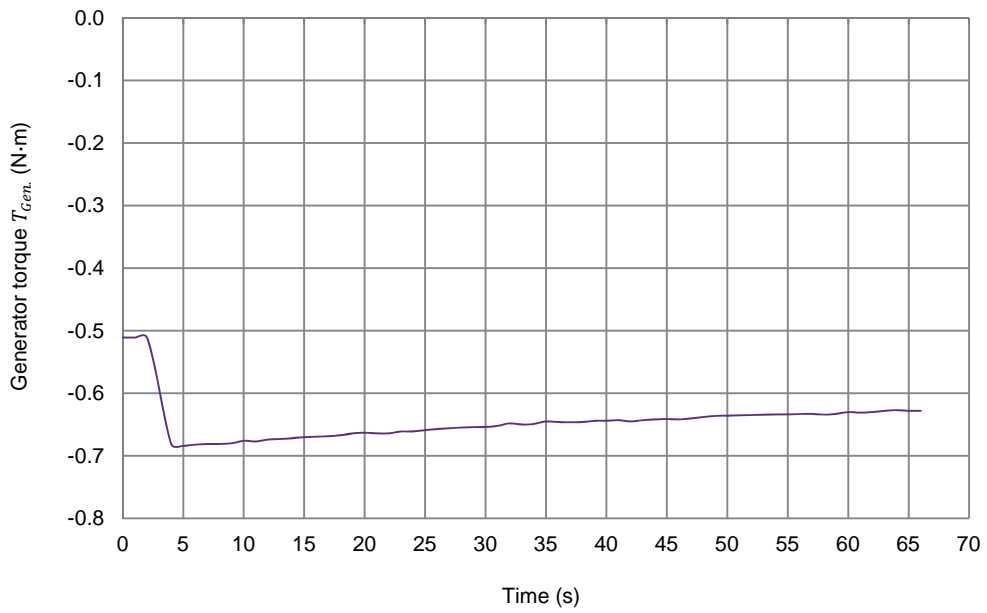
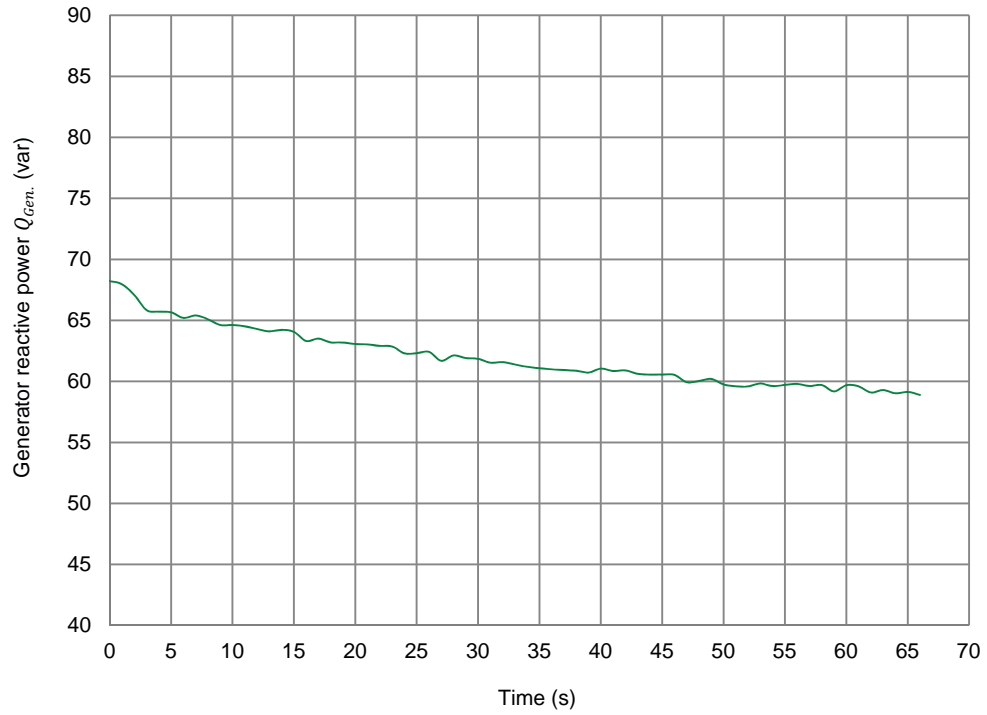

Graphs of the synchronous generator parameters as a function of time when the resistive load connected to the generator increases (part 3).

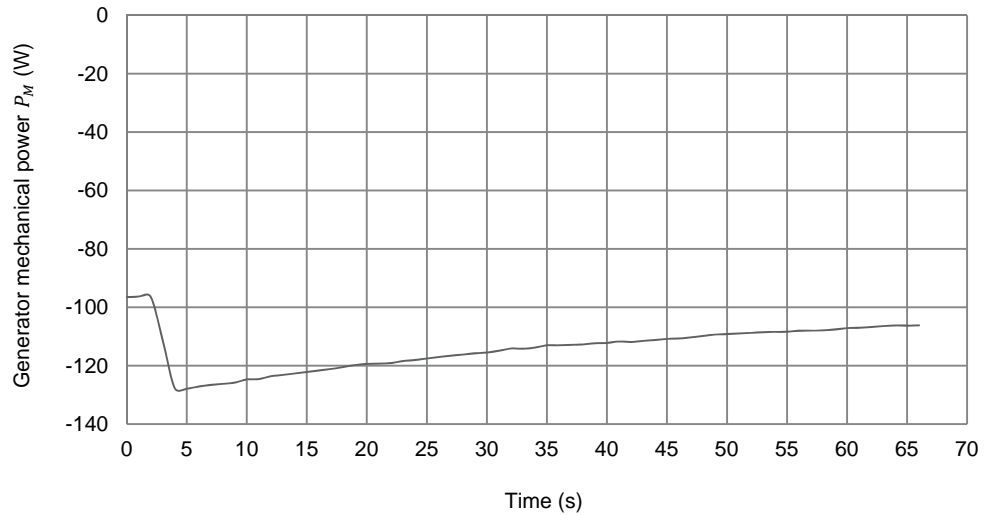

Graphs of the synchronous generator parameters as a function of time when the resistive load connected to the generator increases (part 4).

32. Observe the graphs you just plotted. What happens to the synchronous generator speed $n_{Gen.}$ (and generator frequency $f_{Gen.}$) when the three-phase resistive load connected to the generator increases? Explain briefly.

When the three-phase resistive load connected to the synchronous generator increases, the generator speed $n_{Gen.}$ remains momentarily constant, then decreases gradually. This is because increasing the three-phase resistive load makes the generator active power $P_{Gen.}$ increase instantaneously, thereby causing the generator torque $T_{Gen.}$ (opposing rotation) to also increase instantaneously. However, the synchronous generator speed $n_{Gen.}$ (and thus the generator frequency $f_{Gen.}$) does not decrease instantaneously due to the inertia of the turbine driving the generator, but rather begins to decrease gradually following the increase of the three-phase resistive load.

33. Observe the graphs you just plotted. What happens to the synchronous generator voltage $E_{Gen.}$ when the three-phase resistive load connected to the generator increases? Explain briefly.

When the three-phase resistive load connected to the synchronous generator increases, the generator voltage $E_{Gen.}$ decreases instantaneously, then continues to decrease gradually (until it stabilizes). Increasing the three-phase resistive load makes the generator current $I_{Gen.}$ increase instantaneously, thereby causing the voltage drop across the stator windings to also increase instantaneously. This explains the instantaneous decrease in the generator voltage $E_{Gen.}$. Then, the generator voltage $E_{Gen.}$ continues to decrease (gradually) because the generator speed $n_{Gen.}$ starts to decrease gradually.

34. Do all generator parameters vary as expected according to the theory presented in the exercise discussion?

Yes No

Yes

35. In the **Four-Quadrant Dynamometer/Power Supply** window, adjust the vane opening of the hydraulic-turbine emulator using the **Vane Hydraulic Servomotor Control** slider so that the generator frequency $f_{Gen.}$ is as close as possible to the local ac power network frequency. While doing so, observe the various generator parameters.

36. Wait for the synchronous generator speed to stabilize, then, in the **Generator Control, Metering, and Four-Quadrant Dynamometer/Power Supply** windows, measure the various generator parameters. Record the values below.

Generator frequency $f_{Gen.} =$ _____ Hz

Generator voltage $E_{Gen.} =$ _____ V

Generator current $I_{Gen.} =$ _____ A

Generator active power $P_{Gen.} =$ _____ W

Generator reactive power $Q_{Gen.} =$ _____ var

Generator field current $I_F =$ _____ A

Thyristor bridge firing angle $\alpha =$ _____ °

Generator speed $n_{Gen.} =$ _____ r/min

Generator torque $T_{Gen.} =$ _____ N·m or lbf·in

Generator mechanical power $P_M =$ _____ W

Hydraulic-turbine vane opening = _____ %

Generator frequency $f_{Gen.} = 60.0$ Hz

Generator voltage $E_{Gen.} = 203$ V

Generator current $I_{Gen.} = 0.37$ A

Generator active power $P_{Gen.} = 113$ W

Generator reactive power $Q_{Gen.} = 64.9$ var

Generator field current $I_F = 0.68$ A

Thyristor bridge firing angle $\alpha = 70.2^\circ$

Generator speed $n_{Gen.} = 1800$ r/min

Generator torque $T_{Gen.} = -0.67$ N·m

Generator mechanical power $P_M = -127$ W

Hydraulic-turbine vane opening = 44.6 %

- 37.** Does adjusting the hydraulic-turbine vane opening to compensate for the variation (decrease) in the generator frequency $f_{Gen.}$ caused by an increase in the resistive load connected to the synchronous generator also fully compensate the variation (decrease) in the generator voltage $E_{Gen.}$ caused by the increase in the resistive load? Explain briefly.

No, adjusting the hydraulic-turbine vane opening to compensate the variation (decrease) in the generator frequency $f_{Gen.}$ caused by an increase in the resistive load connected to the synchronous generator does not fully compensate the variation (decrease) in the generator voltage $E_{Gen.}$ caused by the increase in the resistive load. This is because the decrease in the generator voltage $E_{Gen.}$ occurring when the resistive load increases is not only due to the decrease in the generator speed $n_{Gen.}$ but also to the increase in the magnitude of the voltage drop across the stator windings. The voltage drop across the stator windings is not compensated by adjusting the hydraulic-turbine vane opening.

- 38.** In the **Synchronous Generator Control** window, adjust the generator field current I_F using the **Thyristor Bridge Firing Angle α** parameter so that the generator voltage $E_{Gen.}$ is as close as possible to the local ac power network voltage.

From your observations, is it possible to compensate the variation (decrease) in the generator voltage $E_{Gen.}$ by adjusting (increasing) the generator field current I_F using the **Thyristor Bridge Firing Angle α** parameter without having to readjust the vane opening of the hydraulic-turbine emulator to maintain the

generator speed $n_{Gen.}$ (and thus the generator frequency $f_{Gen.}$) at the nominal value? Explain briefly.

No, it is not possible to compensate the variation (decrease) in the generator voltage $E_{Gen.}$ by adjusting (increasing) the generator field current I_F using the *Thyristor Bridge Firing Angle* α parameter without having to readjust the vane opening of the hydraulic-turbine emulator to maintain the generator speed $n_{Gen.}$ (and thus the generator frequency $f_{Gen.}$) at the nominal value. This is because increasing the generator voltage $E_{Gen.}$ causes the generator active power $P_{Gen.}$, and thus the generator torque $T_{Gen.}$, to increase. This, in turn, causes the generator speed $n_{Gen.}$ (and thus the generator frequency $f_{Gen.}$) to decrease. Consequently, the vane opening of the hydraulic-turbine emulator has to be readjusted to maintain the generator speed $n_{Gen.}$ (and thus the generator frequency $f_{Gen.}$) at the nominal value.

39. If necessary, in the *Four-Quadrant Dynamometer/Power Supply* and *Synchronous Generator Control* windows, adjust the vane opening of the hydraulic-turbine emulator using the *Vane Hydraulic Servomotor Control* slider, and the generator field current I_F using the *Thyristor Bridge Firing Angle* α parameter so that the generator frequency $f_{Gen.}$ and voltage $E_{Gen.}$ are as close as possible to the frequency and voltage of the local ac power network.

40. Wait for the synchronous generator parameters to stabilize, then, in the *Generator Control*, *Metering*, and *Four-Quadrant Dynamometer/Power Supply* windows, measure the various generator parameters. Record the values below.

Generator frequency $f_{Gen.} =$ _____ Hz

Generator voltage $E_{Gen.} =$ _____ V

Generator current $I_{Gen.} =$ _____ A

Generator active power $P_{Gen.} =$ _____ W

Generator reactive power $Q_{Gen.} =$ _____ var

Generator field current $I_F =$ _____ A

Thyristor bridge firing angle $\alpha =$ _____ °

Generator speed $n_{Gen.} =$ _____ r/min

Generator torque $T_{Gen.} =$ _____ N·m or lbf·in

Generator mechanical power $P_M =$ _____ W

Hydraulic-turbine vane opening = _____ %

Generator frequency $f_{Gen.} = 60.0$ Hz

Generator voltage $E_{Gen.} = 208$ V

Generator current $I_{Gen.} = 0.38$ A

Generator active power $P_{Gen.} = 119$ W

Generator reactive power $Q_{Gen.} = 68.7$ var

Generator field current $I_F = 0.73$ A

Thyristor bridge firing angle $\alpha = 68.5^\circ$

Generator speed $n_{Gen.} = 1800$ r/min

Generator torque $T_{Gen.} = -0.71$ N·m

Generator mechanical power $P_M = -134$ W

Hydraulic-turbine vane opening = 46.3 %

- 41.** From your observations, is it possible to compensate the variation in the synchronous generator frequency $f_{Gen.}$ and voltage $E_{Gen.}$ caused by a variation of the resistive load connected to the generator by adjusting the hydraulic-turbine vane opening and the generator field current I_F (i.e., by adjusting the firing angle of the thyristor bridge)? Explain briefly.

Yes, it is possible to compensate the variation in the synchronous generator frequency $f_{Gen.}$ and voltage $E_{Gen.}$ caused by a variation of the resistive load connected to the generator by adjusting the hydraulic-turbine vane opening and the generator field current I_F (i.e., by adjusting the firing angle of the thyristor bridge). Adjusting the hydraulic-turbine vane opening allows the variation in the generator speed $n_{Gen.}$ (and thus the resulting variation in the generator frequency $f_{Gen.}$) which occurs when the resistive load connected to the synchronous generator varies to be fully compensated. It also allows the variation in the generator voltage $E_{Gen.}$ which occurs when the resistive load connected to the synchronous generator varies to be partially compensated. Adjusting the generator field current I_F by adjusting the firing angle of the thyristor bridge allows the variation in the generator voltage $E_{Gen.}$ which occurs when the resistive load connected to the synchronous generator varies to be completely compensated.

42. In the **Data Table**, clear all recorded data without modifying the record and timer settings. Start the timer to start data recording. Then, on the **Inductive Load** module, decrease the reactance of the three-phase load to the value indicated in Table 2. As you do so, observe what happens to the generator parameters.



*For optimal results, modify the switch settings simultaneously on the three legs of the **Resistive Load** and **Inductive Load** in order to avoid operation with an unbalanced load as much as possible.*

Table 2. Reactance value to be used for the three-phase inductive load in Figure 28.

| Local ac power network | | X_{L1}, X_{L2}, X_{L3} (Ω) |
|------------------------|-------------------|--|
| Voltage (V) | Frequency (Hz) | |
| 120 | 60 | 400 |
| 220 | 50 | 1467 |
| 240 | 50 | 1600 |
| 220 | 60 | 1467 |

43. Wait for the timer in the **Data Table** to stop data recording. Then, save the recorded data.
44. Using the data you recorded, plot graphs of the synchronous generator speed n_{Gen} , voltage E_{Gen} , current I_{Gen} , active power P_{Gen} , reactive power Q_{Gen} , torque T_{Gen} , and mechanical power P_M as a function of time when the inductive load connected to the generator increases.

The resulting graphs of the synchronous generator speed $n_{Gen.}$, voltage $E_{Gen.}$, current $I_{Gen.}$, active power $P_{Gen.}$, reactive power $Q_{Gen.}$, torque $T_{Gen.}$, and mechanical power P_M as a function of time when the inductive load connected to the generator increases are presented below.

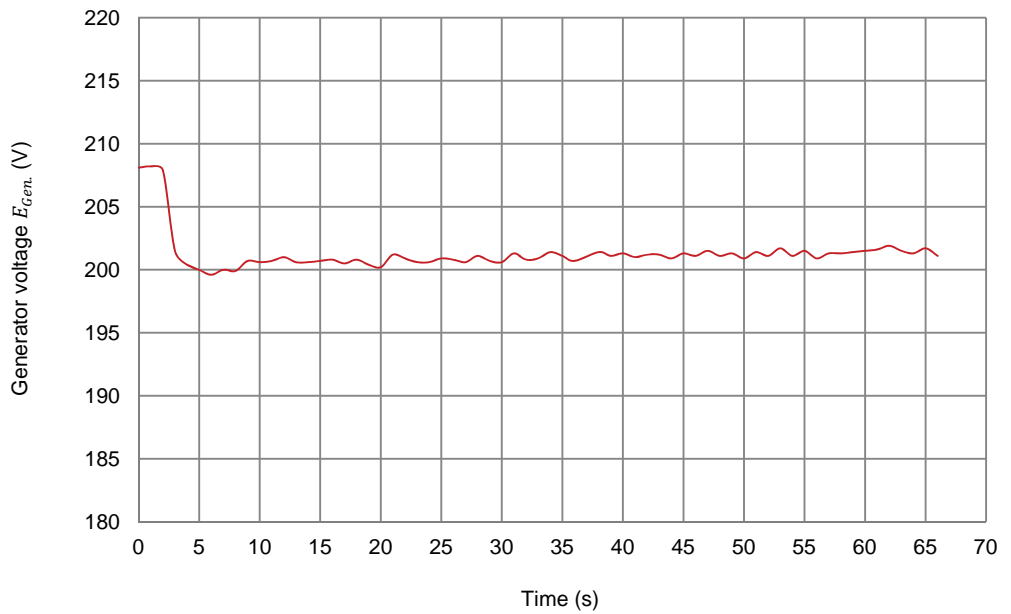
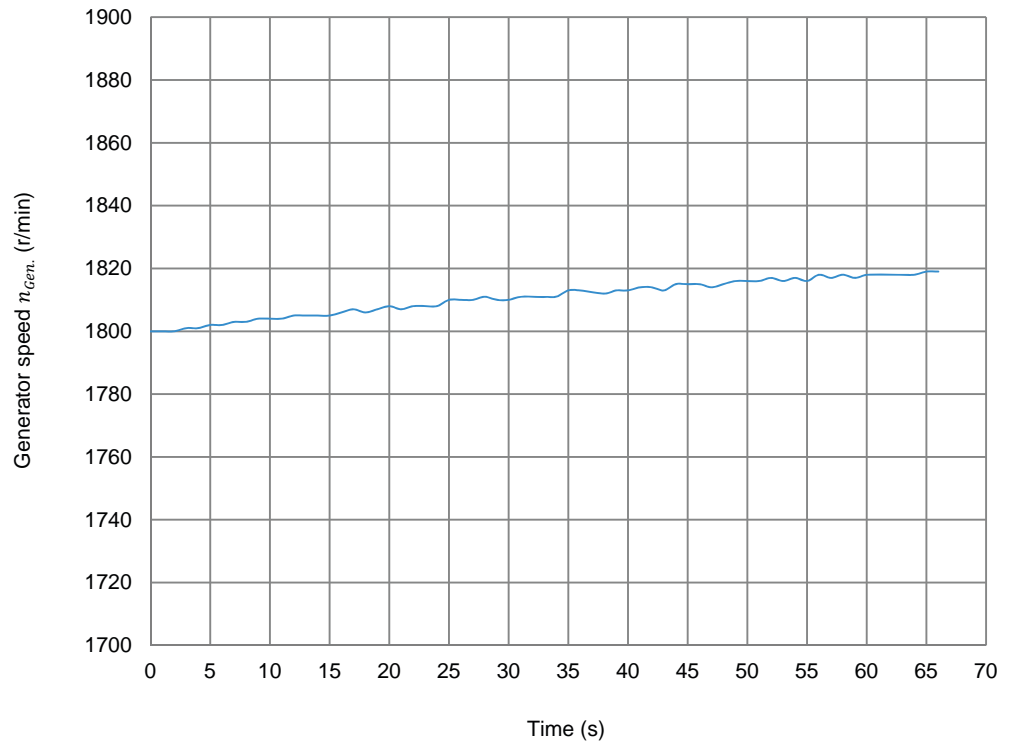

Graphs of the synchronous generator parameters as a function of time when the inductive load connected to the generator increases (part 1).

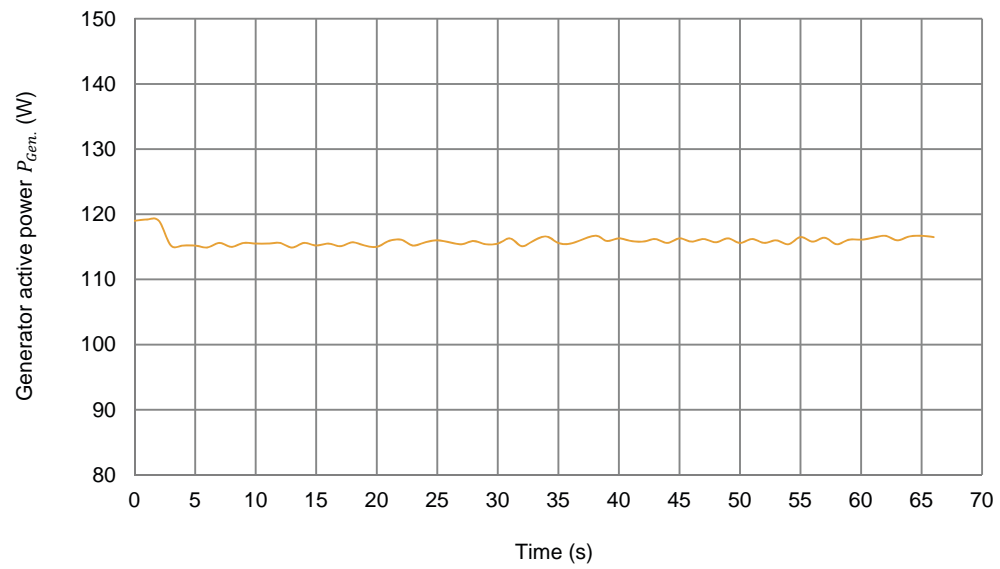
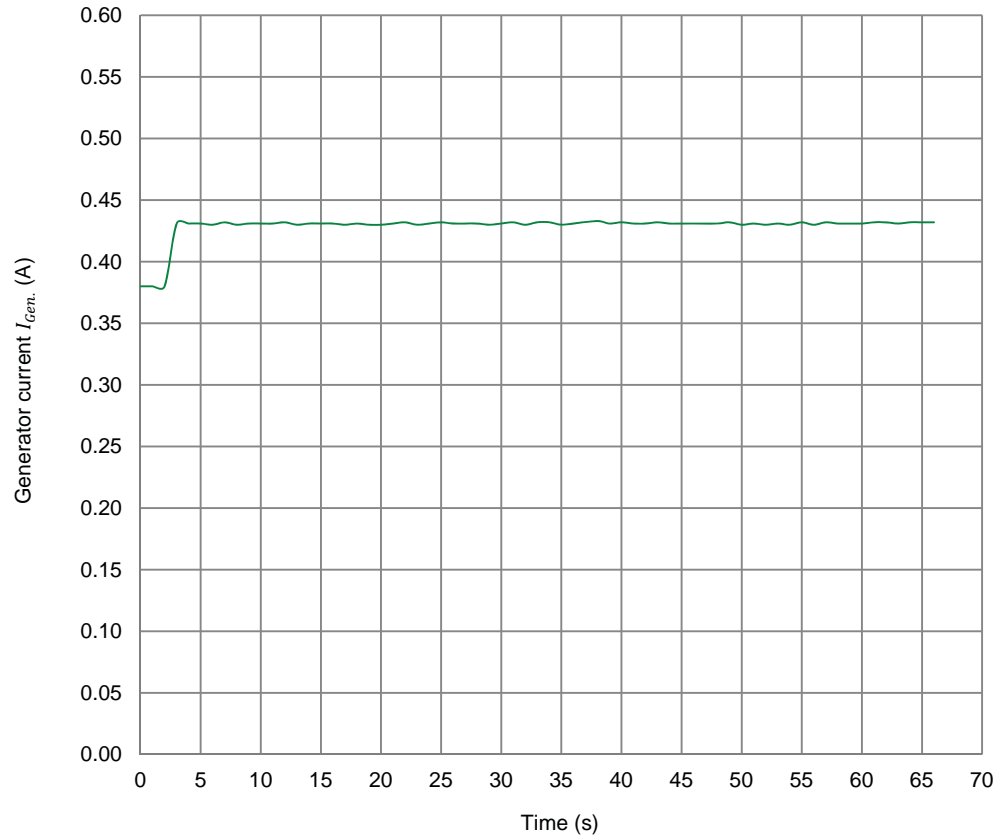

Graphs of the synchronous generator parameters as a function of time when the inductive load connected to the generator increases (part 2).

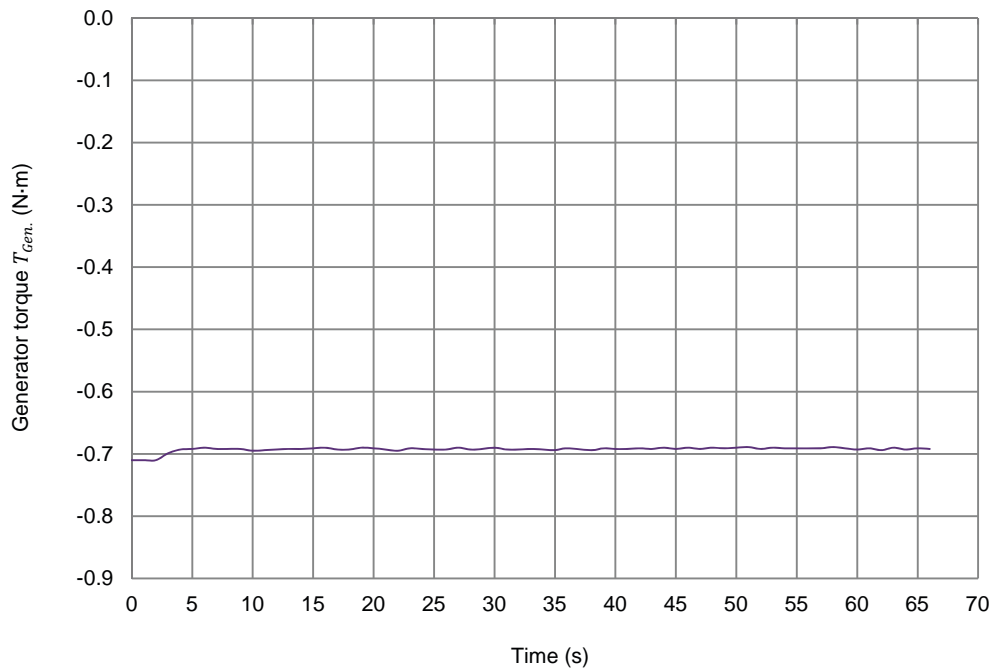
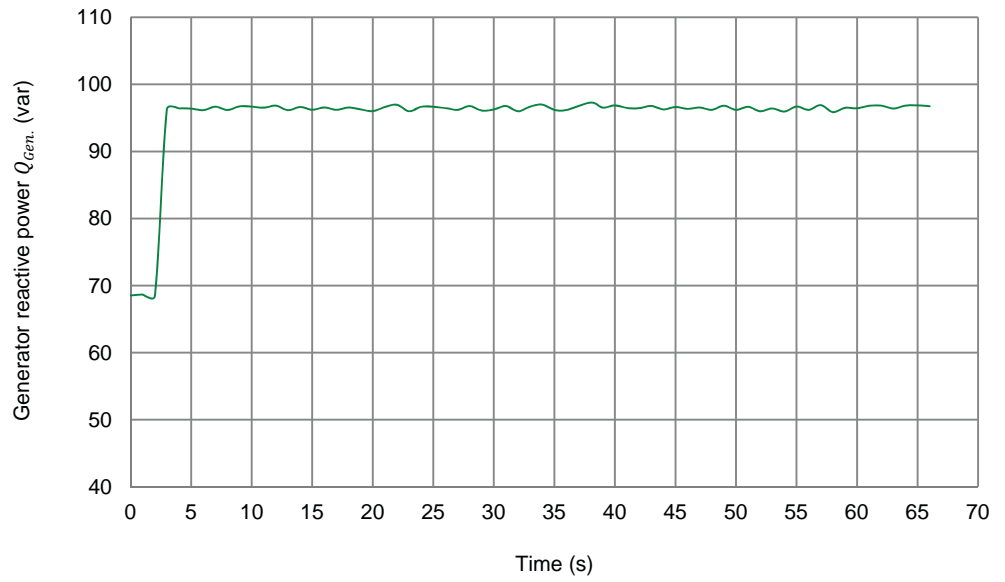

Graphs of the synchronous generator parameters as a function of time when the inductive load connected to the generator increases (part 3).

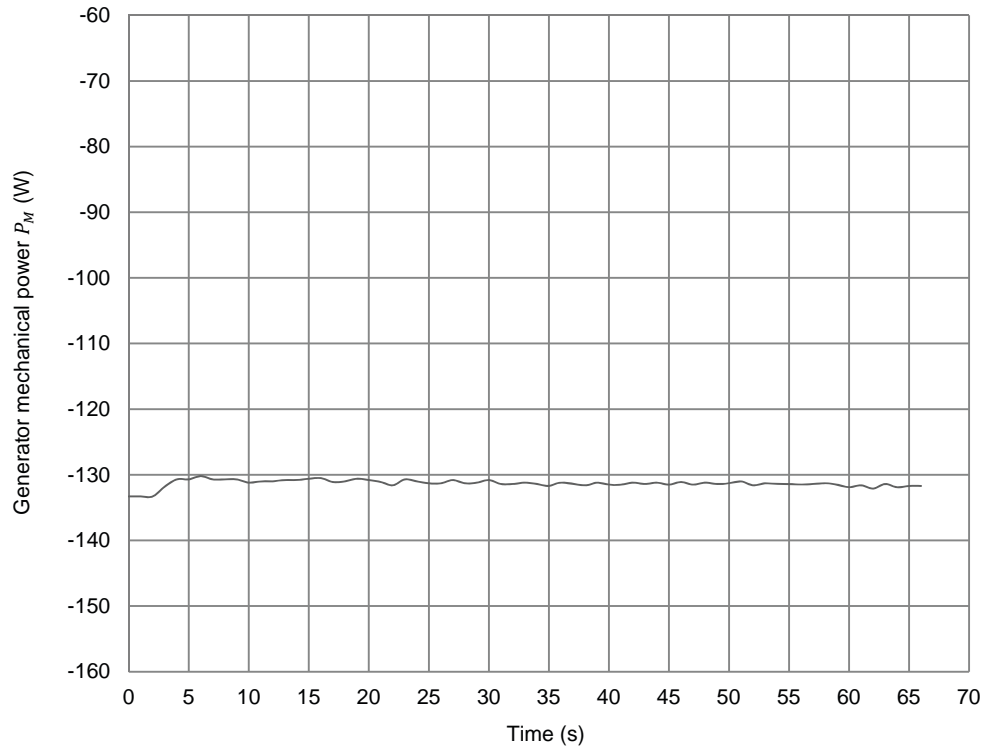

Graphs of the synchronous generator parameters as a function of time when the inductive load connected to the generator increases (part 4).

45. Observe the graphs you just plotted. What happens to the synchronous generator speed $n_{Gen.}$ (and generator frequency $f_{Gen.}$) when the three-phase inductive load connected to the generator increases? Explain briefly.

When the three-phase inductive load connected to the synchronous generator increases, the generator speed $n_{Gen.}$ (and generator frequency $f_{Gen.}$) remains momentarily constant, then increases slightly and in a gradual fashion. This is because increasing the three-phase inductive load makes the generator voltage $E_{Gen.}$ decrease instantaneously, thereby causing the generator active power $P_{Gen.}$ and torque $T_{Gen.}$ (opposing rotation) to also decrease instantaneously. However, the synchronous generator speed $n_{Gen.}$ (and thus the generator frequency $f_{Gen.}$) does not increase instantaneously due to the inertia of the turbine driving the generator, but rather begins to increase slightly and in a gradual fashion following the increase of the three-phase inductive load.

46. Observe the graphs you just plotted. What happens to the synchronous generator voltage $E_{Gen.}$ when the three-phase inductive load connected to the generator increases? Explain briefly.

When the three-phase inductive load connected to the synchronous generator increases, the generator voltage $E_{Gen.}$ decreases instantaneously, then increases slightly in a gradual fashion. Increasing the three-phase inductive load makes the generator current $I_{Gen.}$ increase instantaneously, thereby causing the voltage drop across the stator windings to also increase instantaneously. This explains the instantaneous decrease in the generator voltage $E_{Gen.}$. Then, the generator voltage $E_{Gen.}$ starts to increase (slightly and in a gradual fashion) because the generator speed $n_{Gen.}$ starts to increase slightly and in a gradual fashion.

47. Do all generator parameters vary as expected according to the theory presented in the exercise discussion?

Yes No

Yes

48. In the *Synchronous Generator Control* window, adjust the generator field current I_F using the *Thyristor Bridge Firing Angle* α parameter so that the generator voltage $E_{Gen.}$ is as close as possible to the local ac power network voltage.

49. From your observations, is it possible to compensate the variation (decrease) in the generator voltage $E_{Gen.}$ by adjusting (increasing) the generator field current I_F without having to readjust the vane opening of the hydraulic-turbine emulator to bring the generator speed $n_{Gen.}$ (and thus the generator frequency $f_{Gen.}$) to the nominal value? Explain briefly.

No, it is not possible to compensate the variation (decrease) in the generator voltage $E_{Gen.}$ by adjusting (increasing) the generator field current I_F without having to readjust the vane opening of the hydraulic-turbine emulator to bring the generator speed $n_{Gen.}$ (and thus the generator frequency $f_{Gen.}$) to the nominal value. This is because increasing the generator voltage $E_{Gen.}$ causes the generator active power $P_{Gen.}$ and thus the generator torque $T_{Gen.}$ to increase. This, in turn, causes the generator speed $n_{Gen.}$ (and thus the generator frequency $f_{Gen.}$) to decrease gradually. This decrease in the generator speed $n_{Gen.}$ causes the generator voltage $E_{Gen.}$ to once again decrease, making it impossible to fully compensate the generator voltage $E_{Gen.}$. Consequently, both the vane opening of the hydraulic-turbine emulator and the firing angle of the thyristor three-phase bridge have to be readjusted simultaneously to bring the generator voltage $E_{Gen.}$ at the nominal value.

50. If necessary, in the **Four-Quadrant Dynamometer/Power Supply** and **Synchronous Generator Control** windows, adjust the vane opening of the hydraulic-turbine emulator using the **Vane Hydraulic Servomotor Control** slider, and the generator field current I_F using the **Thyristor Bridge Firing Angle α** parameter so that the generator frequency $f_{Gen.}$ and voltage $E_{Gen.}$ are as close as possible to the frequency and voltage of the local ac power network.
51. Wait for the synchronous generator parameters to stabilize, then, in the **Generator Control**, **Metering**, and **Four-Quadrant Dynamometer/Power Supply** windows, measure the various generator parameters. Record the values below.

Generator frequency $f_{Gen.} =$ _____ Hz

Generator voltage $E_{Gen.} =$ _____ V

Generator current $I_{Gen.} =$ _____ A

Generator active power $P_{Gen.} =$ _____ W

Generator reactive power $Q_{Gen.} =$ _____ var

Generator field current $I_F =$ _____ A

Thyristor bridge firing angle $\alpha =$ _____ °

Generator speed $n_{Gen.} =$ _____ r/min

Generator torque $T_{Gen.} =$ _____ N·m or lbf·in

Generator mechanical power $P_M =$ _____ W

Hydraulic-turbine vane opening = _____ %

Generator frequency $f_{Gen.} = 60.0$ Hz

Generator voltage $E_{Gen.} = 208$ V

Generator current $I_{Gen.} = 0.45$ A

Generator active power $P_{Gen.} = 123$ W

Generator reactive power $Q_{Gen.} = 103$ var

Generator field current $I_F = 0.80$ A

Thyristor bridge firing angle $\alpha = 65.0^\circ$

Generator speed $n_{Gen.} = 1800$ r/min

Generator torque $T_{Gen.} = -0.74 \text{ N}\cdot\text{m}$

Generator mechanical power $P_M = -139 \text{ W}$

Hydraulic-turbine vane opening = 47.9 %

52. Record (in the spaces below) the hydraulic-turbine vane opening and the thyristor bridge firing angle α you obtained with the initial load conditions and the generator frequency $f_{Gen.}$ and voltage $E_{Gen.}$ at the nominal values (recorded in step 20).

Hydraulic-turbine vane opening = _____ %

Thyristor bridge firing angle $\alpha =$ _____ °

Hydraulic-turbine vane opening and thyristor bridge firing angle α obtained during the initial load conditions with the generator frequency $f_{Gen.}$ and voltage $E_{Gen.}$ at the nominal values.

Hydraulic-turbine vane opening = 36.4 %

Thyristor bridge firing angle $\alpha = 70.2^\circ$

Record (in the spaces below) the hydraulic-turbine vane opening and the thyristor bridge firing angle α you obtained after the resistive load increase and the generator frequency $f_{Gen.}$ and voltage $E_{Gen.}$ is set back to the nominal values (recorded in step 40).

Hydraulic-turbine vane opening = _____ %

Thyristor bridge firing angle $\alpha =$ _____ °

Hydraulic-turbine vane opening and thyristor bridge firing angle α obtained after the resistive load increase with the generator frequency $f_{Gen.}$ and voltage $E_{Gen.}$ at the nominal values.

Hydraulic-turbine vane opening = 46.3 %

Thyristor bridge firing angle $\alpha = 68.5^\circ$

Record (in the spaces below) the hydraulic-turbine vane opening and the thyristor bridge firing angle α you obtained after the inductive load increase and the generator frequency $f_{Gen.}$ and voltage $E_{Gen.}$ is set back to the nominal values (recorded in step 51).

Hydraulic-turbine vane opening = _____ %

Thyristor bridge firing angle $\alpha =$ _____ °

Hydraulic-turbine vane opening and thyristor bridge firing angle α obtained after the inductive load increase with the generator frequency $f_{Gen.}$ and voltage $E_{Gen.}$ at the nominal values.

Hydraulic-turbine vane opening = 47.9%

Thyristor bridge firing angle $\alpha = 65.0^\circ$

53. From the values you recorded in the previous step, compare the increase in the hydraulic-turbine vane opening required to compensate the decrease in the synchronous generator speed $n_{Gen.}$ after a resistive load increase to the increase in the hydraulic-turbine vane opening required to compensate the decrease in the synchronous generator speed $n_{Gen.}$ after an inductive load increase. Explain briefly.

The increase in the hydraulic-turbine vane opening required to compensate the decrease in the synchronous generator speed $n_{Gen.}$ is much higher after a resistive load increase than after an inductive load increase (+9.9% compared to +1.6%). This is because the amount of active power $P_{Gen.}$ which the synchronous generator supplies to the load increases much more after a resistive load increase than after an inductive load increase. Consequently, the decrease in the generator speed $n_{Gen.}$ that needs to be compensated is also much higher after a resistive load increase than after an inductive load increase.

From the values you recorded in the previous step, compare the decrease in the thyristor bridge firing angle α required to compensate the decrease in the synchronous generator voltage $E_{Gen.}$ after a resistive load increase to the decrease in the thyristor bridge firing angle α required to compensate the decrease in the synchronous generator voltage $E_{Gen.}$ after an inductive load increase. Explain briefly.

The decrease in the thyristor bridge firing angle α required to compensate the decrease in the synchronous generator voltage $E_{Gen.}$ is higher after an inductive load increase than after a resistive load increase (-3.5° compared to -1.7°). This is because the amount of reactive power $Q_{Gen.}$ which the synchronous generator exchanges with the load increases much more after an inductive load increase than after a resistive load increase. Consequently, the decrease in the generator voltage $E_{Gen.}$ that needs to be compensated is also much higher after an inductive load increase than after a resistive load increase.

54. From your observations, is it possible to compensate the variation in the synchronous generator frequency $f_{Gen.}$ and voltage $E_{Gen.}$ caused by a variation of the inductive load connected to the generator by adjusting the hydraulic-turbine vane opening and the generator field current I_F (i.e., by adjusting the firing angle of the thyristor bridge)? Explain briefly.

Yes, it is possible to compensate the variation in the synchronous generator frequency $f_{Gen.}$ and voltage $E_{Gen.}$ caused by a variation of the inductive load connected to the generator by adjusting the hydraulic-turbine vane opening and the generator field current I_F (i.e., by adjusting the firing angle of the thyristor bridge). This is mainly achieved by adjusting the generator field current I_F (using the firing angle of the thyristor bridge) in order to compensate for the variation in the generator voltage $E_{Gen.}$ which occurs when the inductive load connected to the synchronous generator varies. The slight variation in the generator speed $n_{Gen.}$ and thus in the generator frequency $f_{Gen.}$, is compensated by slightly adjusting the hydraulic-turbine vane opening.

55. Is the process of manually adjusting the generator frequency $f_{Gen.}$ and voltage $E_{Gen.}$ back to their nominal values after a load disturbance fast?

Yes No

No

Is the process of manually adjusting the generator frequency $f_{Gen.}$ and voltage $E_{Gen.}$ back to their nominal values after a load disturbance precise?

Yes No

Yes

56. Is it convenient to manually adjust the frequency $f_{Gen.}$ and voltage $E_{Gen.}$ of a turbine-driven synchronous generator back to their nominal values after a load disturbance?

Yes No

No

Log of generator frequency and voltage in manual generator operation

In this section, you will set the Data Table to record the generator frequency and voltage. You will then set the resistance and reactance of the three-phase resistive-inductive load connected to the synchronous generator to various values, manually readjusting for each value the generator frequency and voltage to their nominal values. You will let the generator operate for 1 minute for each load setting. You will save the data recorded in the Data Table, as you will use the measured values for comparison purposes in Exercise 3.

57. Make the necessary switch settings on the **Resistive Load** and on the **Inductive Load** so that the resistance and reactance of the three-phase resistive-inductive load are infinite.

58. In the **Four-Quadrant Dynamometer/Power Supply** and **Synchronous Generator Control** windows, adjust the vane opening of the hydraulic-turbine emulator and the generator field current so that the generator frequency and voltage are as close as possible to the frequency and voltage of the local ac power network.

59. In the **Data Table** window, clear all recorded data, as well as all record and timer settings.

Set the timer to make 900 records with an interval of 1 second between each record. This corresponds to a 15 minute data recording period.

Set the **Data Table** to record the synchronous generator frequency $f_{Gen.}$ and voltage $E_{Gen.}$ indicated in the **Synchronous Generator Control** window, as well as the time associated with each record.

60. In the **Data Table**, start the timer to start data recording.

Make the necessary switch settings on the **Resistive Load** and on the **Inductive Load** in order to successively obtain the ten combinations of load resistance and reactance values indicated in Table 3 corresponding to the local ac power network voltage and frequency. For each resistance and reactance combination, let the synchronous generator operate for 1 minute. During this time, repeat step 58. After 1 minute, proceed to the next resistance and reactance combination, whether or not you have had the time to bring the generator frequency and voltage back to their nominal values.



*For optimal results, modify the switch settings simultaneously on the three legs of the **Resistive Load** and **Inductive Load** in order to avoid operation with an unbalanced load as much as possible.*

Table 3. Combinations of resistance and reactance values of the three-phase resistive-inductive load to be used in the circuit of Figure 28 for different local ac power network voltages and frequencies.

| Local ac power network | | | Resistances $R_1, R_2,$ and R_3 and reactances $X_{L1}, X_{L2},$ and X_{L3} | | | | | | | | | |
|------------------------|----------------|---------|---|-----------------|-----------------|-----------------|-----------------|-----------------|-----------------|-----------------|-----------------|------------------|
| Voltage (V) | Frequency (Hz) | | 1 st | 2 nd | 3 rd | 4 th | 5 th | 6 th | 7 th | 8 th | 9 th | 10 th |
| 120 | 60 | $R =$ | 600 | 600 | 400 | 1200 | 1200 | 1200 | 400 | 600 | 600 | 600 |
| | | $X_L =$ | ∞ | 600 | 600 | 600 | ∞ | 1200 | 1200 | 1200 | ∞ | 600 |
| 220 | 50 | $R =$ | 2200 | 2200 | 1467 | 4400 | 4400 | 4400 | 1467 | 2200 | 2200 | 2200 |
| | | $X_L =$ | ∞ | 2200 | 2200 | 2200 | ∞ | 4400 | 4400 | 4400 | ∞ | 2200 |
| 240 | 50 | $R =$ | 2400 | 2400 | 1600 | 4800 | 4800 | 4800 | 1600 | 2400 | 2400 | 2400 |
| | | $X_L =$ | ∞ | 2400 | 2400 | 2400 | ∞ | 4800 | 4800 | 4800 | ∞ | 2400 |
| 220 | 60 | $R =$ | 2200 | 2200 | 1467 | 4400 | 4400 | 4400 | 1467 | 2200 | 2200 | 2200 |
| | | $X_L =$ | ∞ | 2200 | 2200 | 2200 | ∞ | 4400 | 4400 | 4400 | ∞ | 2200 |

61. In the Data Table window, stop the timer, then save the recorded data. This recorded data will be used for comparison in Exercise 3.

An example of a graph of the synchronous generator frequency $f_{Gen.}$ as a function of time when the generator resistive-inductive load varies is shown below. Note that the recorded data will be used for comparison in Exercise 3.

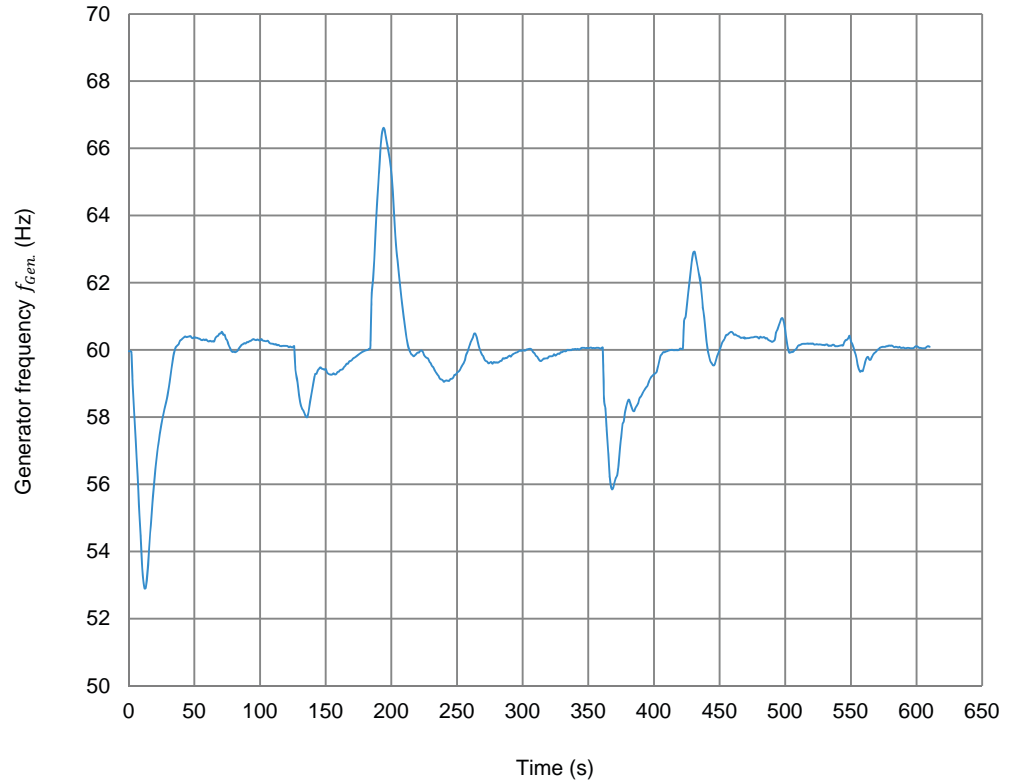

Synchronous generator frequency $f_{Gen.}$ as a function of time when the resistive-inductive load connected to the synchronous generator varies.

An example of a graph of the synchronous generator voltage $E_{Gen.}$ as a function of time when the generator resistive-inductive load varies is shown below. Note that the recorded data will be used for comparison in Exercise 3.

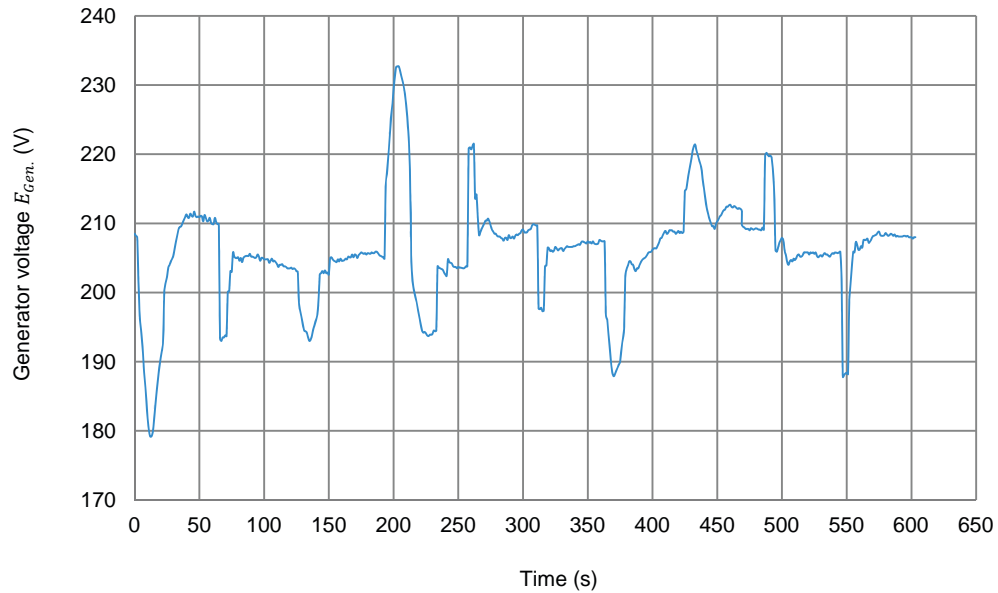

Synchronous generator voltage $E_{Gen.}$ as a function of time when the resistive-inductive load connected to the synchronous generator varies.

62. In the *Synchronous Generator Control* window, set the *Relay Output* parameter to *Low* to force disconnection of the synchronous generator from the load.
63. In the *Four-Quadrant Dynamometer/Power Supply* window, close the vane completely using the *Vane Hydraulic Servomotor Control* slider. In the *Synchronous Generator Control* window, adjust the *Thyristor Bridge Firing Angle α* parameter so that the generator field current is minimal. Wait for the hydraulic turbine driving the generator to stop rotating, then stop the hydraulic-turbine emulator by clicking the *Start/Stop* button or by setting the *Status* parameter to *Stopped*.

In the *Synchronous Generator Control* window, stop the hydropower generator by clicking the *Start/Stop* button or by setting the *Status* parameter to *Stopped*.

On the *Power Supply*, turn the three-phase ac power source off.

64. Close *LVDAC-EMS*, then turn off all the equipment. Disconnect all leads and return them to their storage location.

CONCLUSION

In this exercise, you became familiar with the effect of load variations on the operation of a turbine-driven synchronous generator. You learned how to control the frequency and voltage of a turbine-driven synchronous generator. You were introduced to the operating principles of an auto-excited brushless synchronous generator.

REVIEW QUESTIONS

1. What are the three main types of hydropower plants? Describe each type briefly.

The three main types of hydropower plants are listed below:

- Dam hydropower plants: dam hydropower plants basically consist of a dam used to impede water flow and create a water reservoir. The water from this reservoir can then be allowed to flow in the turbines when electrical power is needed. The amount of electrical power generated using a dam hydropower plant mainly depends on the amount of power used and the head of water.
- Run-of-river hydropower plants: run-of-river hydropower plants consist of a dam used to impede the flow of water without creating a water reservoir. The amount of electrical power generated using a run-of-river hydropower plant mainly depends on the velocity and volume of the water flowing through the turbines.
- Tidal hydropower plants: tidal hydropower plants use the power of tides to generate hydroelectricity. Since tides are due to the gravitational interaction between the Moon and Sun and the Earth's rotation, the amount of electrical power generated using a tidal hydropower plant is extremely constant and predictable.

2. Briefly explain the passage of water through a dam hydropower plant during periods of electricity generation, from the water reservoir to the water outlet.

Water accumulates in the water reservoir due to the dam impeding the flow of water. Water accesses the adjustable vane of each hydraulic turbine through the water intake and penstock of the dam. During periods of electricity generation, the adjustable vanes (whose opening is determined by the electrical power demand) allow water to flow through the hydraulic turbine near the bottom of the dam. The turbine is mechanically coupled to the rotor shaft of a synchronous generator and causes it to rotate, generating electrical power. The water flowing in the turbine then exits through the draft tube located below the turbine. It ends up in the reservoir downstream of the dam.

3. Give one advantage and one disadvantage of hydropower electricity generation. Briefly explain each one.

The main advantages of hydropower electricity generation are listed below:

- Renewable energy: hydropower electricity generation relies on water, a renewable resource (it is continually renewed through the cycle of water), just as solar power and wind power. This is due to the prime mover of hydropower electricity generation being water.
- Low CO₂ emissions: hydropower electricity generation produces very few CO₂ emissions, especially in comparison to electricity generation through the combustion of fossil fuels such as coal and natural gases.
- Flexibility: hydropower electricity generation is very flexible. The power output of a hydropower plant can be increased and decreased very rapidly to meet the demand. The construction of a dam and a water reservoir even allows the plant to operate during periods of drought.
- Low power cost: once the hydropower plant is constructed, it can produce electricity at a very low cost, especially when compared to other types of electricity generation. This is because the prime mover of hydropower electricity generation (water) is free.

The main disadvantages of hydropower electricity generation are listed below:

- Ecosystem loss: hydropower plants can have very significant effects on the ecosystem surrounding the plant. This is especially true with any dam hydropower plant, which necessitates the flooding of a large land area to obtain the water reservoir required. This can potentially result in the destruction of flora and fauna, as well as in the displacement of human populations.
- Water shortage: the amount of water flowing through a hydropower plant can decrease over the years depending on environmental conditions. This can greatly reduce the total power output of the plant and render it less productive. Seasonal droughts can also be a problem when no water reservoir is available (as for run-of-river hydropower plants) or when the water reservoir is too small.
- High initial costs: the initial construction costs of a hydropower plant are very high. This is especially true for dam hydropower plants, due to the high construction costs of the dam in addition to the compensation money that must generally be paid to relocated populations.

4. How is it possible to control the frequency of the voltage produced by a turbine-driven synchronous generator? Explain briefly.

The frequency of the voltage produced by a turbine-driven synchronous generator is controlled by monitoring and regulating the generator speed. The regulation of the generator speed is achieved by varying the opening of the adjustable vanes determining the amount of water flowing in the hydraulic turbine. To maintain the generator frequency constant, the amount of water flowing through the turbine must be continually adjusted (by changing the opening of the adjustable vanes) so that the amount of mechanical power produced by the hydraulic turbine maintains the generator speed constant no matter what the active power demand is.

5. How is it possible to control the magnitude of the voltage produced by a turbine-driven synchronous generator? Explain briefly.

Control of the magnitude of the voltage produced by a turbine-driven synchronous generator is achieved by adjusting the generator field current. The higher the generator field current, the higher the generator voltage. Controlling the voltage produced by a turbine-driven synchronous generator using the generator field current is commonly achieved by connecting an external three-phase ac power source and a thyristor three-phase bridge to the generator field winding. Varying the firing angle of the thyristor three-phase bridge varies the voltage at the dc side of the bridge and thus the magnitude of the current flowing through the field winding. In order to maintain the generator voltage constant, it is necessary to dynamically adjust the firing angle of the thyristor bridge and thus the magnitude of the generator field current so that the resulting increase or decrease in the generator voltage fully compensates for the voltage fluctuations due to changes in the load value.

Bibliography

Breeze, Paul, *Power Generation Technologies*, 1st ed., Oxford: Elsevier, 2005, ISBN 0-7506-6313-8.

Hotakainen, Markus and Jacob Klimstra, *Smart Power Generation*, 1st ed., Helsinki: Avain Publishers, 2011, ISBN 978-951-692-846-6.

Jyortirmay, Mathur and Hermann-Josef Wagner, *Introduction to Hydro Energy Systems*, 1st ed., Berlin: Springer, 2011, ISBN 978-3-642-20708-2.

Sayers, A. T., *Hydraulic and Compressible Flow Turbomachines*, 1st ed., New Delhi: CBLS, 2003, ISBN 1-878907-93-X.