

Electricity and New Energy

High-Frequency Power Transformers

Courseware Sample

86378-F0

Order no.: 86378-10
First Edition
Revision level: 11/2014

By the staff of Festo Didactic

© Festo Didactic Ltée/Ltd, Quebec, Canada 2011
Internet: www.festo-didactic.com
e-mail: did@de.festo.com

Printed in Canada
All rights reserved
ISBN 978-2-89640-543-5 (Printed version)
ISBN 978-2-89640-797-2 (CD-ROM)
Legal Deposit – Bibliothèque et Archives nationales du Québec, 2011
Legal Deposit – Library and Archives Canada, 2011

The purchaser shall receive a single right of use which is non-exclusive, non-time-limited and limited geographically to use at the purchaser's site/location as follows.

The purchaser shall be entitled to use the work to train his/her staff at the purchaser's site/location and shall also be entitled to use parts of the copyright material as the basis for the production of his/her own training documentation for the training of his/her staff at the purchaser's site/location with acknowledgement of source and to make copies for this purpose. In the case of schools/technical colleges, training centers, and universities, the right of use shall also include use by school and college students and trainees at the purchaser's site/location for teaching purposes.

The right of use shall in all cases exclude the right to publish the copyright material or to make this available for use on intranet, Internet and LMS platforms and databases such as Moodle, which allow access by a wide variety of users, including those outside of the purchaser's site/location.

Entitlement to other rights relating to reproductions, copies, adaptations, translations, microfilming and transfer to and storage and processing in electronic systems, no matter whether in whole or in part, shall require the prior consent of Festo Didactic GmbH & Co. KG.

















Information in this document is subject to change without notice and does not represent a commitment on the part of Festo Didactic. The Festo materials described in this document are furnished under a license agreement or a nondisclosure agreement.

Festo Didactic recognizes product names as trademarks or registered trademarks of their respective holders.

All other trademarks are the property of their respective owners. Other trademarks and trade names may be used in this document to refer to either the entity claiming the marks and names or their products. Festo Didactic disclaims any proprietary interest in trademarks and trade names other than its own.

Safety and Common Symbols

The following safety and common symbols may be used in this manual and on the equipment:

Symbol	Description
	DANGER indicates a hazard with a high level of risk which, if not avoided, will result in death or serious injury.
	WARNING indicates a hazard with a medium level of risk which, if not avoided, could result in death or serious injury.
	CAUTION indicates a hazard with a low level of risk which, if not avoided, could result in minor or moderate injury.
	CAUTION used without the <i>Caution, risk of danger</i> sign  , indicates a hazard with a potentially hazardous situation which, if not avoided, may result in property damage.
	Caution, risk of electric shock
	Caution, hot surface
	Caution, risk of danger
	Caution, lifting hazard
	Caution, hand entanglement hazard
	Notice, non-ionizing radiation
	Direct current
	Alternating current
	Both direct and alternating current
	Three-phase alternating current
	Earth (ground) terminal

Safety and Common Symbols









Symbol	Description
	Protective conductor terminal
	Frame or chassis terminal
	Equipotentiality
	On (supply)
	Off (supply)
	Equipment protected throughout by double insulation or reinforced insulation
	In position of a bi-stable push control
	Out position of a bi-stable push control

Table of Contents

Preface	VII
About This Manual	IX
To the Instructor	XI
Introduction High-Frequency Power Transformers	1
DISCUSSION OF FUNDAMENTALS	1
Power rating of transformers.....	1
Effect of frequency on the power rating of transformers.....	1
Use of HF power transformers.....	3
Exercise 1 High-Frequency Power Transformer Operation.....	5
DISCUSSION	5
High-frequency power transformers in switched-mode power supplies and insulated dc-to-dc converters.....	5
Switched-mode power supplies.....	5
DC-to-DC converters.....	7
Power efficiency of SMPS and insulated dc-to-dc converters	8
Topologies of SMPS and insulated dc-to-dc converters.....	9
Insulated dc-to-dc converter implemented using a push- pull converter.....	9
PROCEDURE	12
Electrical insulation between the input and output of an insulated dc-to-dc converter.....	12
Set up and connections	12
Voltage regulation and power efficiency	14
Regulating the output voltage using the duty cycle	20
Appendix A Equipment Utilization Chart	25
Appendix B Glossary of New Terms.....	27
Appendix C Circuit Diagram Symbols.....	29
Appendix D Impedance Table for the Load Modules.....	35
Index of New Terms	37
Acronyms	39
Bibliography	41

Preface

The production of energy using renewable natural resources such as wind, sunlight, rain, tides, geothermal heat, etc., has gained much importance in recent years as it is an effective means of reducing greenhouse gas (GHG) emissions. The need for innovative technologies to make the grid smarter has recently emerged as a major trend, as the increase in electrical power demand observed worldwide makes it harder for the actual grid in many countries to keep up with demand. Furthermore, electric vehicles (from bicycles to cars) are developed and marketed with more and more success in many countries all over the world.

To answer the increasingly diversified needs for training in the wide field of electrical energy, the Electric Power Technology Training Program was developed as a modular study program for technical institutes, colleges, and universities. The program is shown below as a flow chart, with each box in the flow chart representing a course.

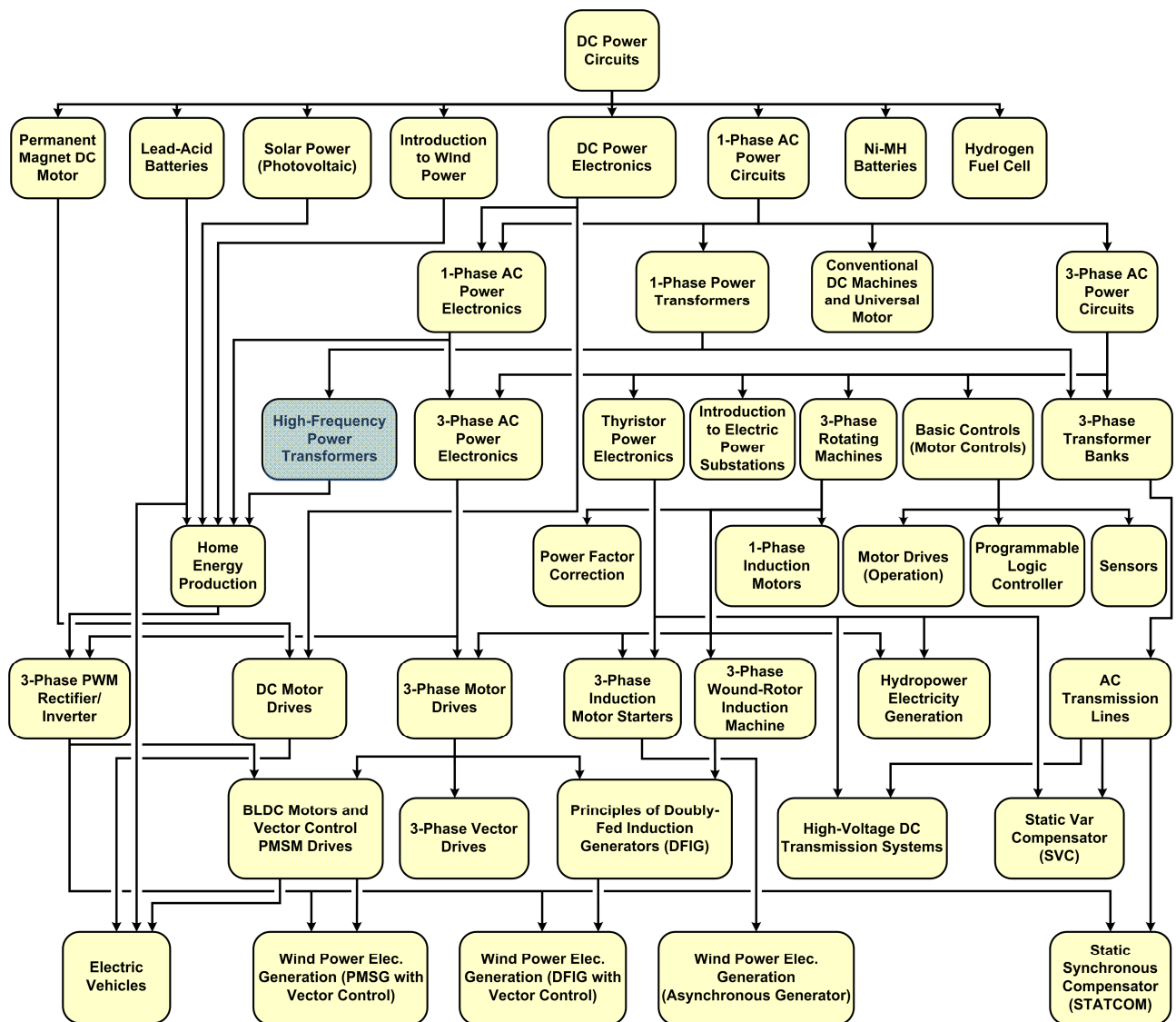

The Electric Power Technology Training Program.

Preface

The program starts with a variety of courses providing in-depth coverage of basic topics related to the field of electrical energy such as ac and dc power circuits, power transformers, rotating machines, ac power transmission lines, and power electronics. The program then builds on the knowledge gained by the student through these basic courses to provide training in more advanced subjects such as home energy production from renewable resources (wind and sunlight), large-scale electricity production from hydropower, large-scale electricity production from wind power (doubly-fed induction generator [DFIG], synchronous generator, and asynchronous generator technologies), smart-grid technologies (SVC, STATCOM, HVDC transmission, etc.), storage of electrical energy in batteries, and drive systems for small electric vehicles and cars.

Do you have suggestions or criticism regarding this manual?

If so, send us an e-mail at did@de.festo.com.

The authors and Festo Didactic look forward to your comments.

About This Manual

This manual, *High-Frequency Power Transformers*, demonstrates how high-frequency switching can be used to increase the power handling capability of power transformers. This type of power transformer is commonly used to perform dc-to-dc conversion in switched-mode power supplies (SMPS), as well as in grid-tied inverters used for home energy production.

The student is introduced to the operation of high-frequency power transformers commonly used to implement switched-mode power supplies in a large variety of small electrical equipment, such as digital television sets, home entertainment systems, desktop computers, computer peripherals, etc, and in insulated dc-to-dc converters such as those found in many grid-tied inverters powered by solar panels or wind turbines.

The equipment for the course mainly consists of the Insulated DC-to-DC Converter module and the Four-Quadrant Dynamometer/Power Supply. The operation of the Insulated DC-to-DC Converter module and Four-Quadrant Dynamometer/Power Supply is controlled by the LVDAC-EMS software (via the Data Acquisition and Control Interface), which also provides the instrumentation required to measure and record the experimental data.

Safety considerations

Safety symbols that may be used in this manual and on the equipment are listed in the Safety Symbols table at the beginning of the manual.

Safety procedures related to the tasks that you will be asked to perform are indicated in each exercise.

Make sure that you are wearing appropriate protective equipment when performing the tasks. You should never perform a task if you have any reason to think that a manipulation could be dangerous for you or your teammates.

Prerequisite

As a prerequisite to this course, you should have read the manuals titled *Trainer DC Power Circuits*, p.n. 86350, *Single-Phase AC Power Circuits*, p.n. 86358, and *Single-Phase Power Transformers*, p.n. 86377.

Systems of units

Units are expressed using the International System of Units (SI) followed by the units expressed in the U.S. customary system of units (between parentheses).

To the Instructor

You will find in this Instructor Guide all the elements included in the Student Manual together with the answers to all questions, results of measurements, graphs, explanations, suggestions, and, in some cases, instructions to help you guide the students through their learning process. All the information that applies to you is placed between markers and appears in red.

Accuracy of measurements

The numerical results of the hands-on exercises may differ from one student to another. For this reason, the results and answers given in this manual should be considered as a guide. Students who correctly performed the exercises should expect to demonstrate the principles involved and make observations and measurements similar to those given as answers.

Equipment installation

In order for students to be able to perform the exercises in the Student Manual, the Electric Power Technology Training Equipment must have been properly installed, according to the instructions given in the user guide Electric Power Technology Training Equipment, part number 38486-E.

Sample Exercise
Extracted from
the Student Manual
and the Instructor Guide

High-Frequency Power Transformer Operation

EXERCISE OBJECTIVE When you have completed this exercise, you will be familiar with the operation of high-frequency power transformers.

DISCUSSION OUTLINE The Discussion of this exercise covers the following points:

- High-frequency power transformers in switched-mode power supplies and insulated dc-to-dc converters
- Power efficiency of SMPS and insulated dc-to-dc converters
- Topologies of SMPS and insulated dc-to-dc converters
- Insulated dc-to-dc converter implemented using a push-pull converter

DISCUSSION **High-frequency power transformers in switched-mode power supplies and insulated dc-to-dc converters**

As mentioned in the introduction of this manual, high-frequency (HF) power transformers are used in switched-mode power supplies (SMPS) and insulated dc-to-dc converters to transfer electrical power from a power source to a load, which is the same function as LF power transformers. However, HF power transformers are smaller, lighter, and cheaper than their LF counterparts, making them ideal in applications where minimal space, weight, and cost are at a premium.

Switched-mode power supplies

Figure 4 shows a generic block diagram of an SMPS. In this circuit, the ac supply is first rectified and then filtered by a capacitor to produce an unregulated dc supply. The unregulated dc supply is fed directly to a high-speed power switching section which consists of electronic switches connected as a chopper or an inverter. The electronic switches are generally fast-switching power semiconductor devices such as MOSFETs or IGBTs. These power semiconductor devices are switched on and off to intermittently apply the unregulated dc voltage to the primary of the HF power transformer. The switching pulses are normally fixed frequency (20 kHz to 200 kHz) and variable duty cycle. Hence, a bipolar voltage-pulse train of suitable magnitude and duty cycle appears at the transformer secondary. This bipolar voltage-pulse train is rectified by a high-speed rectifier, and then smoothed by the output filter, which is either a capacitor or capacitor/inductor arrangement. The transfer of power has to be carried out with the lowest losses possible to maintain the best possible power efficiency. Thus, optimum design of the passive and magnetic components, and selection of the proper power semiconductors is critical. Note that in most SMPS units, the HF power transformer is generally of the step-down type since low dc voltage outputs are usually required.

As the load increases, the voltage at the dc output of an SMPS decreases because voltage drops across the various circuit components (diodes, electronic switches, and the HF power transformer) increase. This is similar to the voltage decrease observed at the secondary of an LF power transformer when the load (resistive or inductive) increases. As shown in the block diagram of Figure 4, a voltage feedback loop is used in the SMPS to maintain the voltage at the dc output constant. The voltage feedback loop also compensates for fluctuations (ripple) in the rectified input voltage. Generally, most SMPS units operate using fixed-frequency, pulse-width modulation (PWM), where the duration of the on time (i.e., the duty cycle) is varied on a cycle-to-cycle basis to compensate for changes in the rectified input voltage and output load. The voltage feedback loop subtracts the dc output voltage from the voltage command. Whenever the dc output voltage differs from the voltage command, an error signal is produced. The error signal, after some proportional and integral (PI) amplification, is used to adjust the duty cycle of the switching signals applied to the high-speed electronic switches in such a way as to correct the error on the dc output voltage. For instance, when the dc output voltage is lower than the voltage command, the error signal has a positive polarity and this makes the duty cycle increase. Consequently, the rms value of the ac voltage at the HF power transformer increases, and thus, the dc output voltage increases to compensate the error. When the dc output voltage equals the voltage command, the error signal is zero, and the duty cycle is set to the exact value required to keep the system in equilibrium.

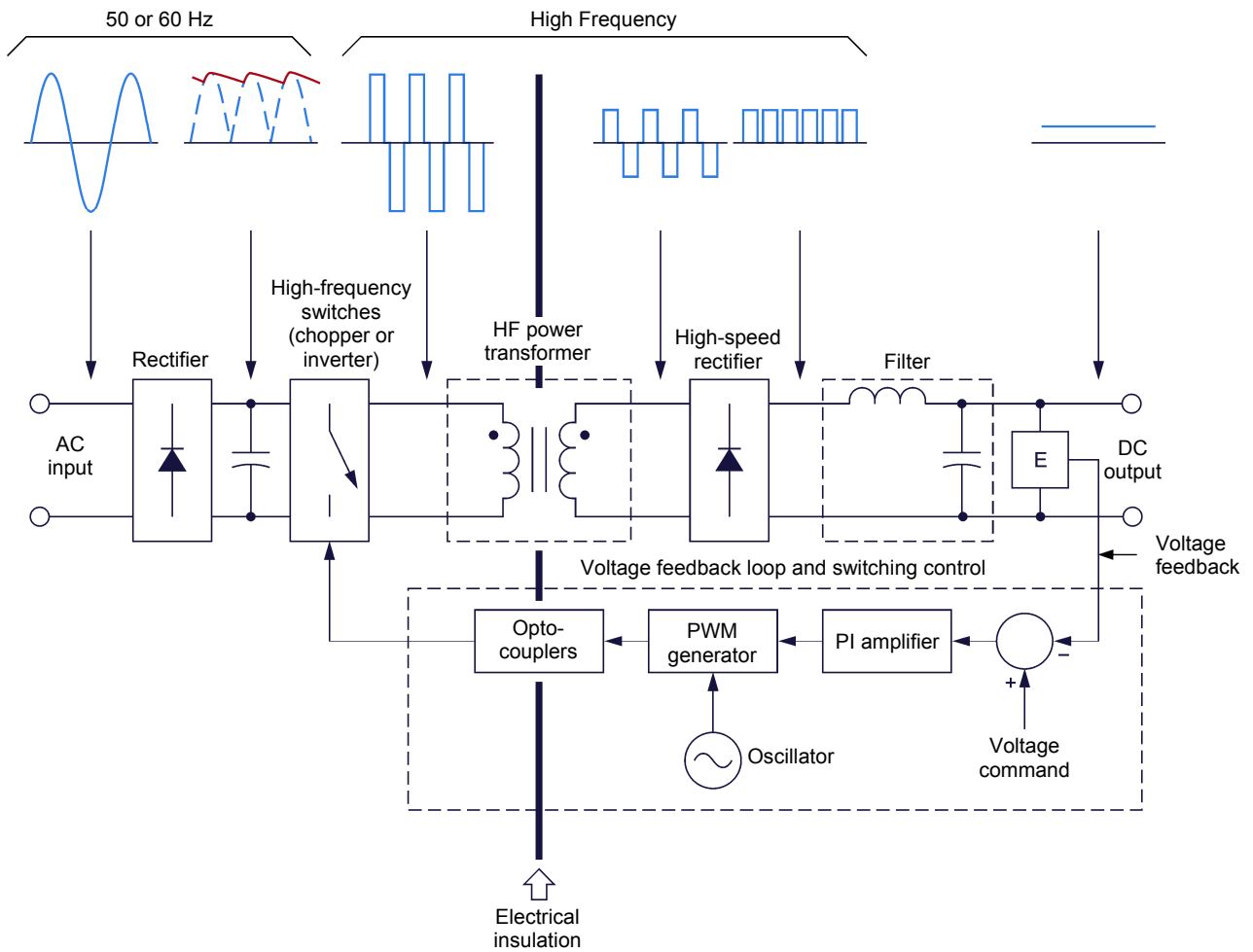

Figure 4. Generic block diagram of a switched-mode power supply.

The use of an HF power transformer in an SMPS provides electrical insulation between the input and output. Consequently, opto-couplers are required in the voltage feedback loop (see generic block diagram of an SMPS in Figure 4) to preserve the electrical insulation between the input and output of the SMPS.

DC-to-DC converters

Figure 5 shows a generic block diagram of an insulated dc-to-dc converter. The insulated dc-to-dc converter is identical to an SMPS except that it does not require a rectifier at the input because it is supplied with dc power that can come from various sources (e.g., a battery, a solar panel, a wind turbine, etc.). Depending on the application requirements, either a step-down or step-up HF transformer can be used, though step-up HF transformers are generally used in most insulated dc-to-dc converters used in grid-tied inverters.

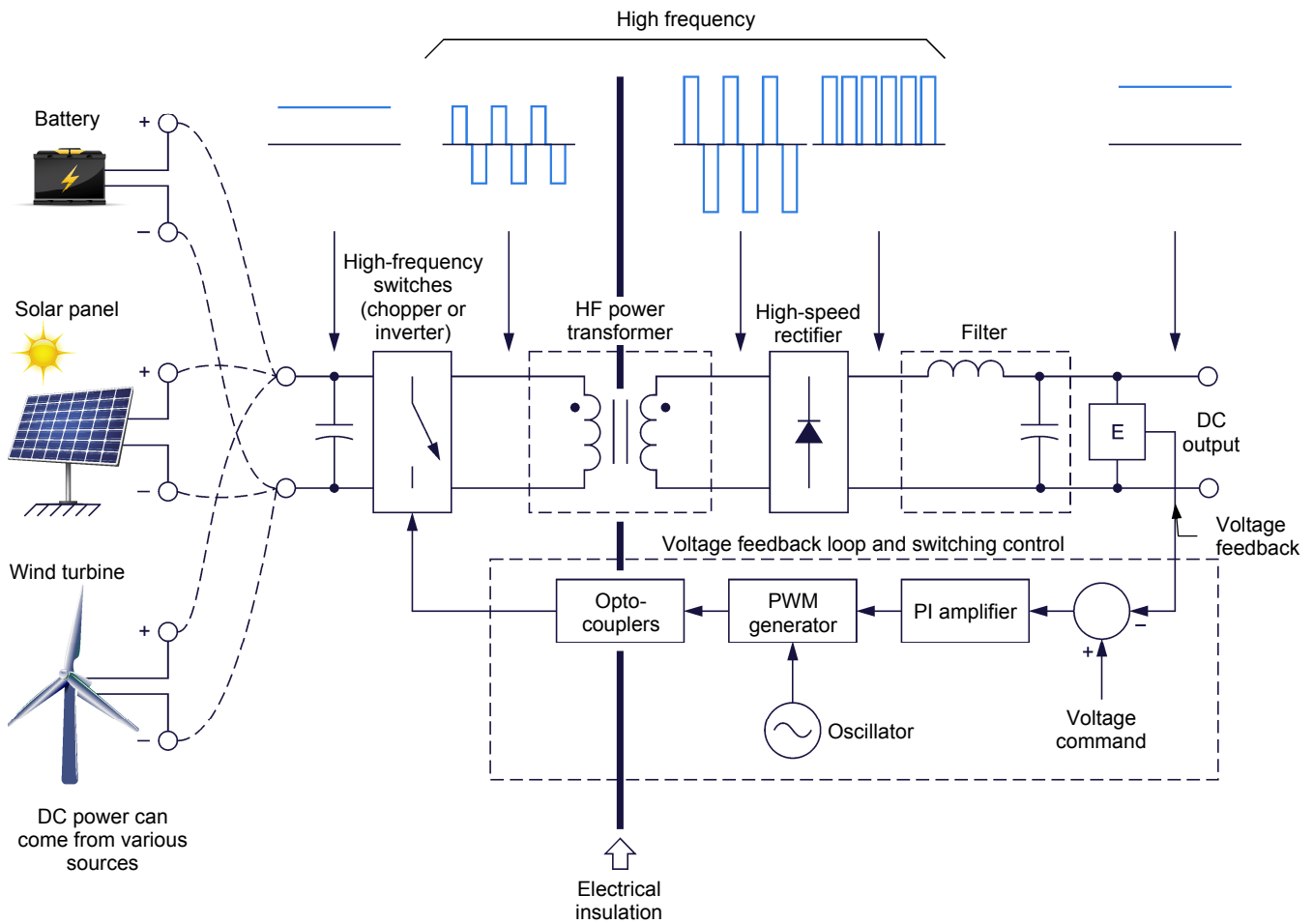

Figure 5. Generic block diagram of a dc-to-dc converter.

Power efficiency of SMPS and insulated dc-to-dc converters

Power efficiencies achieved with SMPS and insulated dc-to-dc converters generally range between 80% and 90%. This may appear as a loss in performance when comparing the above efficiencies to the power efficiency of small LF power transformers, which generally lies between 90% and 95%. However, the dc voltage at the output of an SMPS or dc-to-dc converter is virtually ripple less and regulated while the voltage at the secondary of an LF power transformer is not. Voltage rectification, filtering, and regulation in applications using LF power transformers to produce dc voltage all introduce some additional power losses that may well decrease the overall system efficiency to the point that it falls below that of SMPS or insulated dc-to-dc converters using HF power transformers.

Topologies of SMPS and insulated dc-to-dc converters

Various topologies are available to implement an SMPS or an insulated dc-to-dc converter using an HF power transformer. The main difference between these topologies lies in the configuration of the high-speed electronic switches (chopper or inverter) that convert dc power into high-frequency ac power that feeds the primary of the HF power transformer. The flyback converter, forward converter, push-pull converter, half-bridge converter (inverter with dual-polarity dc power supply), and full-bridge converter (inverter with single-polarity dc power supply) are topologies that are commonly used to implement SMPS and insulated dc-to-dc converters. Note that the remaining of this exercise discussion deals with the push-pull converter topology since it is used in the [Insulated DC-to-DC Converter](#).

Insulated dc-to-dc converter implemented using a push-pull converter

Figure 6 shows a simplified diagram of an insulated dc-to-dc converter implemented using the push-pull converter topology. Figure 7 provides an example of waveforms of voltages and currents related to this circuit. In this example, the duty cycle is 0.33 (33%).

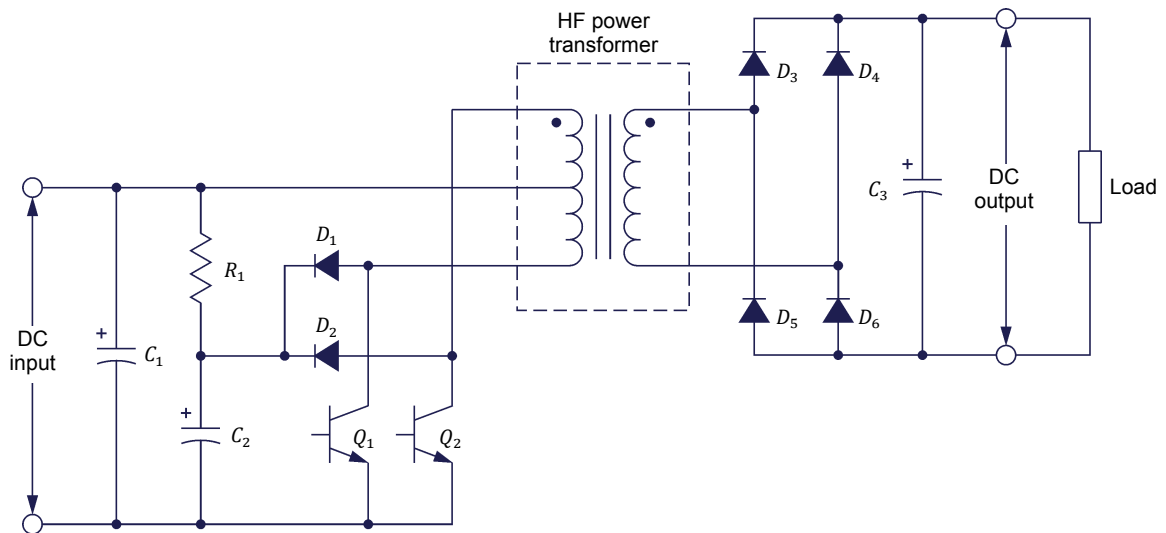

Figure 6. Simplified diagram of an insulated dc-to-dc converter implemented using the push-pull converter topology.

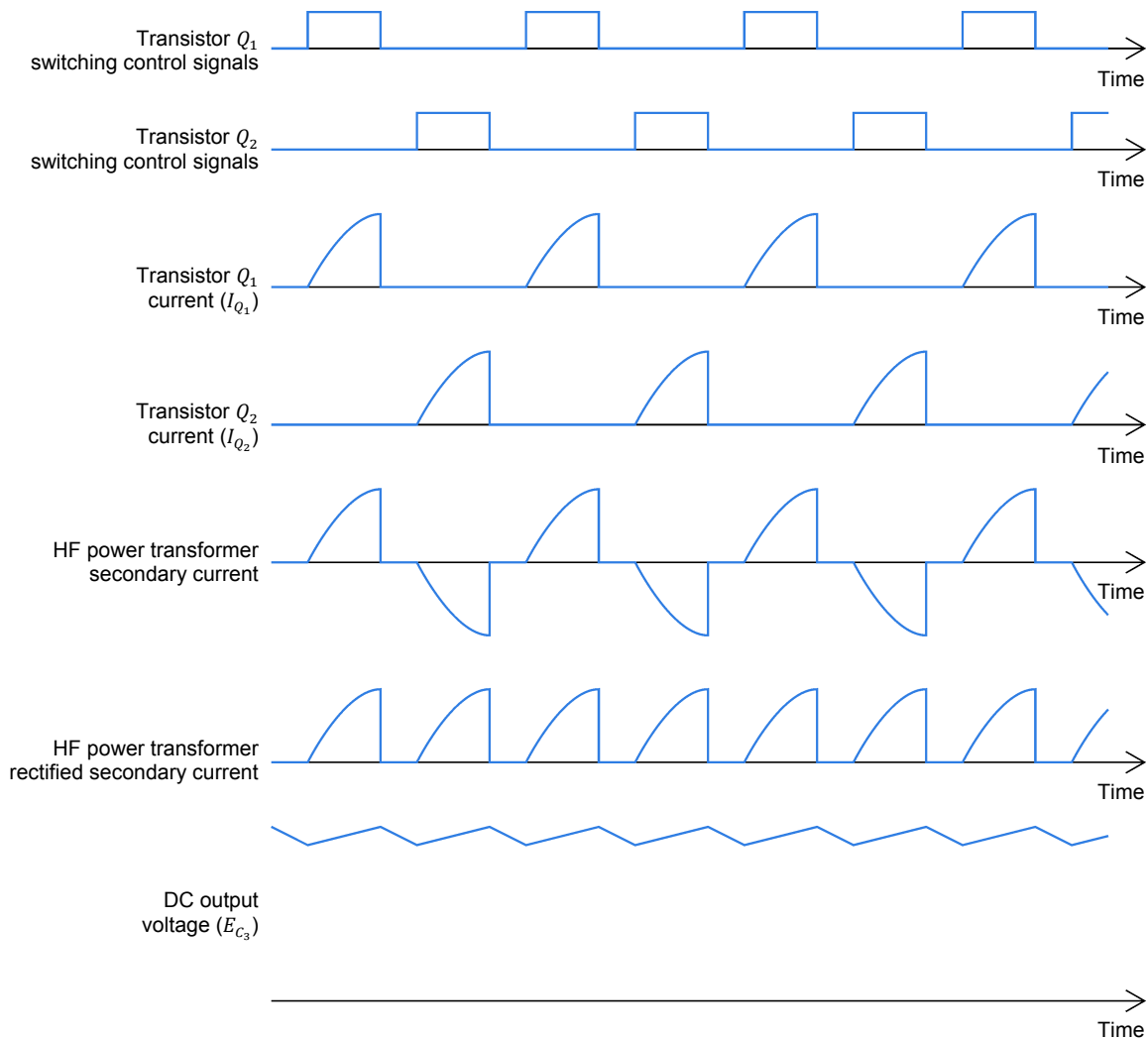

Figure 7. Waveforms of voltages and currents related to the push-pull converter shown in Figure 6.

In the circuit diagram shown in Figure 6, the primary of the HF power transformer has a center tap. Transistors Q_1 and Q_2 are switched on and off alternately. When transistor Q_1 is on, current (I_{Q_1}) flows through the lower part of the HF power transformer primary and the polarity of the voltage pulse induced across the transformer secondary forward biases diodes D_3 and D_6 . Consequently, current flows through the transformer secondary and these diodes via filtering capacitor C_3 and the load, thereby charging capacitor C_3 . On the other hand, when transistor Q_2 is on, current (I_{Q_2}) flows through the upper part of the HF power transformer primary, in the direction opposite to that of the current that flowed in the lower part of the transformer primary. Consequently, the polarity of the voltage pulse induced across the transformer secondary reverses and forward biases diodes D_4 and D_5 . Current thus flows through the transformer secondary (though in the direction opposite to the current that flows in the transformer secondary when diodes D_3 and D_6 were forward biased) and these diodes via filtering capacitor C_3 and the load, thereby charging capacitor C_3 . Note

that when neither of the two transistors is on, capacitor C_3 discharges a little through the load, resulting in dc voltage with some high-frequency ripple at the converter output. In other words, whenever transistors Q_1 and Q_2 complete an on/off cycle, a cycle of alternating current flows through the HF transformer secondary. This current is rectified by the diode bridge, and filtered by capacitor C_3 to obtain a dc output voltage with some high-frequency ripple.

The maximum duty cycle for each of the two transistors (Q_1 and Q_2) is limited to about 0.45 (or 45%) to have a sufficient guard time ensuring that the two transistors cannot be on simultaneously. Diodes D_1 and D_2 , capacitor C_2 , and resistor R_1 allow the leakage and magnetization energy stored in the HF power transformer primary to be channeled back to the input power source when either of the transistors switches off. This reduces the stress imposed to transistors Q_1 and Q_2 , and slightly improves the power efficiency of the circuit. Figure 8 shows the current path through which the leakage and magnetization energy stored in the lower part of the HF power transformer primary is channeled back to the input power source when transistor Q_1 switches off. A similar current path passing through diode D_2 develops when the leakage and magnetization energy stored in the upper part of the HF power transformer primary is channeled back to the input power source when transistor Q_2 switches off. Note that the energy released by each part of the transformer primary charges capacitor C_2 . Resistor R_1 allows capacitor C_2 to subsequently discharge in capacitor C_1 , which is much larger than capacitor C_2 .

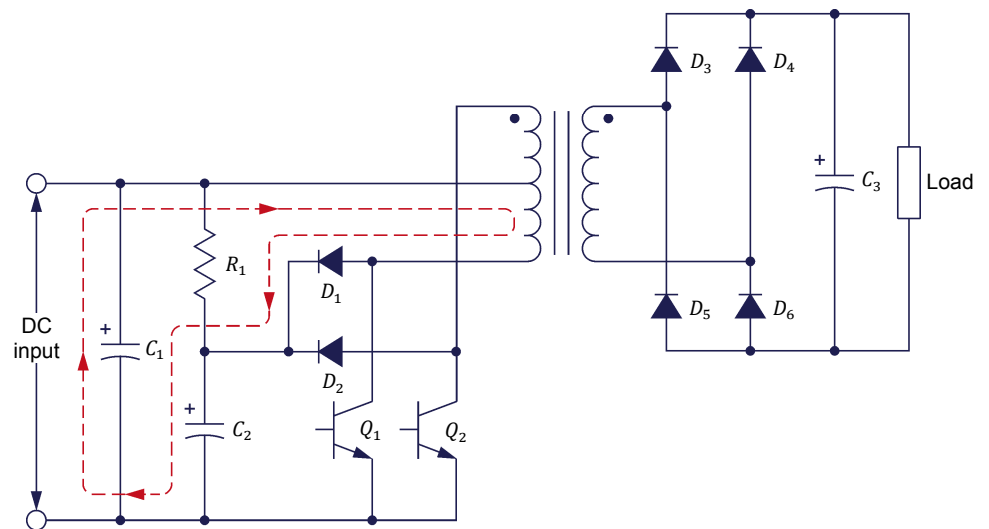

Figure 8. Current path through which the leakage and magnetization energy stored in the lower part of the HF power transformer primary is channeled back to the input power source when transistor Q_1 switches off.

PROCEDURE OUTLINE

The Procedure is divided into the following sections:

- Electrical insulation between the input and output of an insulated dc-to-dc converter
- Set up and connections
- Voltage regulation and power efficiency
- Regulating the output voltage using the duty cycle

PROCEDURE



High voltages are present in this laboratory exercise. Do not make or modify any banana jack connections with the power on unless otherwise specified.

Electrical insulation between the input and output of an insulated dc-to-dc converter

In this part of the exercise, you will measure the resistance between the input and output terminals of the Insulated DC-to-DC Converter to observe the electrical insulation provided by its internal circuitry.

1. Place the [Insulated DC-to-DC Converter](#) module on your work bench.

Using an ohmmeter, measure the resistance between the input and output terminals of the converter.

Do your measurements indicate that the [Insulated DC-to-DC Converter](#) provide electrical insulation between the input and output?

- Yes No

Yes

On the circuit board of the [Insulated DC-to-DC Converter](#), make sure that the switch labeled "**S1**" is set to the **DC/DC** position.

Set up and connections

In this part of the exercise, you will set up and connect the equipment.

2. Refer to the Equipment Utilization Chart in Appendix A to obtain the list of equipment required to perform the exercise.

Install the equipment in the [Workstation](#).

3. Make sure that the main power switch on the **Four-Quadrant Dynamometer/Power Supply** is set to the **O** (off) position, then connect its **Power Input** to an ac power wall outlet.
4. Connect the **Power Input** of the **Data Acquisition and Control Interface** (DACI) to a 24 V ac power supply. Turn the 24 V ac power supply on.

5. Connect the USB port of the **Data Acquisition and Control Interface** to a USB port of the host computer.

Connect the USB port of the **Four-Quadrant Dynamometer/Power Supply** to a USB port of the host computer.

6. Turn the **Four-Quadrant Dynamometer/Power Supply** on, then set the **Operating Mode** switch to **Power Supply**.

7. Turn the host computer on, then start the **LVDAC-EMS** software.

In the **LVDAC-EMS Start-Up** window, make sure that the **Data Acquisition and Control Interface** and the **Four-Quadrant Dynamometer/Power Supply** are detected. Make sure that the **Computer-Based Instrumentation** and **Chopper/Inverter Control** functions for the **Data Acquisition and Control Interface** are available. Select the network voltage and frequency that correspond to the voltage and frequency of your local ac power network, then click the **OK** button to close the **LVDAC-EMS Start-Up** window.

8. Connect **Digital Outputs 1** and **2** of the **Data Acquisition and Control Interface** to **Switching Control Inputs 7** and **8** of the **Insulated DC-to-DC Converter**, respectively, using miniature banana plug leads.

Connect the common (white) terminal of the **Insulated DC-to-DC Converter** to one of the two digital (**D**) common (white) terminals on the **Data Acquisition and Control Interface** using a miniature banana plug lead.

9. Set up the circuit shown in Figure 9 (the electric diagram of the **Insulated DC-to-DC Converter** is simplified in Figure 9 for clarity purpose). In this circuit, E_s is a dc voltage source implemented with the **Four-Quadrant Dynamometer/Power Supply**. E_1 , E_2 , E_4 , I_1 , and I_2 are voltage and current inputs of the **Data Acquisition and Control Interface**. Use the high range (0-40 A) of current input I_1 on the **Data Acquisition and Control Interface** to measure the current at the input of the **Insulated DC-to-DC Converter**.

Notice that the load consists of two resistors (R_1 and R_2) connected in series. Use one resistor section of the **Resistive Load** module to implement each of these two resistors. Initially, set the resistance of each resistor to infinite (∞). Also notice that voltage input E_4 of the **Data Acquisition and Control Interface** is used by **LVDAC-EMS** to monitor the output voltage of the **Insulated**

DC-to-DC Converter in order to protect transistors Q_7 and Q_8 in case of an overload.

In the **Data Acquisition and Control Settings** window of LVDAC-EMS, set the **Range** of current input **I1** to **High (40 A)**.

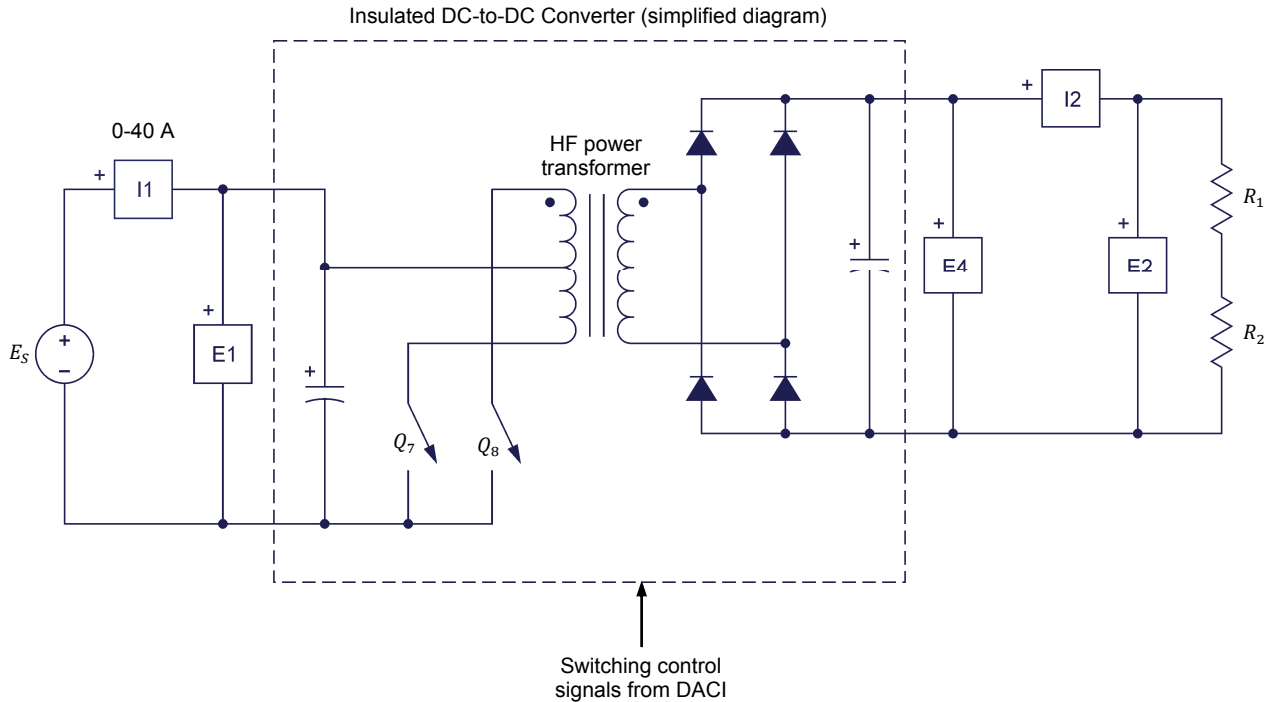

Figure 9. Insulated dc-to-dc converter implemented using the push-pull converter topology.

Voltage regulation and power efficiency

In this part of the exercise, you will use the circuit shown in Figure 9 to evaluate the voltage regulation of the Insulated DC-to-DC Converter by plotting curves of the dc output voltage versus the output power for various duty cycles. You will also evaluate the power efficiency of the Insulated DC-to-DC Converter by plotting curves of the power efficiency versus the output power for various duty cycles.

10. In LVDAC-EMS, open the **Four-Quadrant Dynamometer/Power Supply** window, then make the following settings:

- Set the **Function** parameter to **DC Voltage Source**.
- Make sure that the **Voltage Control** parameter is set to **Knob**. This allows the voltage of the dc voltage source to be controlled manually.
- Set the **Voltage** parameter to 50.0 V by entering **50.0** in the field next to this parameter. This sets the voltage of the dc voltage source to 50.0 V.



The voltage command can also be set by using the *Voltage* control knob in the *Four-Quadrant Dynamometer/Power Supply* window.

- Start the *DC Voltage Source* by setting the *Status* parameter to *Started* or by clicking the *Start/Stop* button or in the *Four-Quadrant Dynamometer/Power Supply* window.

To ensure that the *Insulated DC-to-DC Converter* operates normally, dc voltage must be present at the input of the *Insulated DC-to-DC Converter* before applying the switching control signals to transistors Q_7 and Q_8 .

11. In *LVDAC-EMS*, open the *Chopper/Inverter Control* window, then make the following settings:

- Set the *Function* parameter to *Insulated DC-to-DC Converter*.
- Set the *Duty Cycle* parameter to 45% by entering *45* in the field next to this parameter or by using the control knob in the *Chopper/Inverter Control* window. This sets the duty cycle to 45%.
- Start the *Insulated DC-to-DC Converter* by setting the *Status* parameter to *Started* or by clicking the *Start/Stop* button or in the *Chopper/Inverter Control* window.

CAUTION

Throughout this exercise, always make sure that the two *Transistor Driver Fault* LEDs on the front panel of the *Insulated DC-to-DC Converter* are turned off. If one or both of these LEDs turn on, stop the *Insulated DC-to-DC Converter* window in *LVDAC-EMS*, then press the *Reset* button on the front panel of the *Insulated DC-to-DC Converter* to turn off the LEDs, then resume the manipulations.

12. In *LVDAC-EMS*, open the *Metering window*. Set meters to measure the dc voltage (*E1* and *E2*) and current (*I1* and *I2*) at the input and output of the *Insulated DC-to-DC Converter*.

13. Measure the dc voltage at the input and output of the *Insulated DC-to-DC Converter*. If necessary, very slightly readjust the dc source voltage so that the dc voltage at the converter input is 50.0 V.

Do the voltages displayed by meters *E1* and *E2* (input and output voltages of the converter, respectively) indicate that the HF power transformer in the insulated dc-to-dc converter is a step-up or step-down unit?

The voltage (≈ 250 V) at the output of the *Insulated DC-to-DC Converter* is much higher than the voltage (50 V) at the input. This indicates that the HF power transformer in the *Insulated DC-to-DC Converter* is a step-up unit.

14. In the **Metering** window, set two other meters to measure the power at the input [**PQS1 (E1, I1)**] and output [**PQS2 (E2, I2)**] of the **Insulated DC-to-DC Converter**. Also set another meter to measure the power efficiency (**P2/P1**) of the **Insulated DC-to-DC Converter**.

In **LVDAC-EMS**, open the **Data Table** window. Set the **Data Table** to record the duty cycle of the converter, the voltages, currents, and power at the input and output of the converter [meters **E1, E2, I1, I2, PQS1 (E1, I1), PQS2 (E2,I2)**], as well as the power efficiency (meter **P2/P1**) of the converter.

15. Make sure that the resistance of resistors R_1 and R_2 is set to infinite.

In the **Data Table**, click the **Record Data** button to record the duty cycle of the converter, the voltages, currents, and power at the input and output of the converter, as well as the power efficiency of the converter.

Successively set the resistance of resistors R_1 and R_2 to each of the combination of values shown in Table 1 to make the load resistance value vary by steps. For each load resistance value, readjust the dc source voltage so that the dc voltage at the converter input is 50.0 V. Then record in the **Data Table** the duty cycle of the converter, the voltages, currents, and power at the input and output of the converter, as well as the power efficiency of the converter.



The resistance values of R_1 and R_2 depend on your local ac power network voltage and frequency. Appendix D of this manual lists the switch settings and connections to perform on the Resistive Load module in order to obtain various resistance values at your local ac power network voltage and frequency.

In the **Data Table**, save the recorded data. Transfer the data you saved to a spreadsheet application.

Table 1. Resistance values of R_1 and R_2 for various ac power networks.

Local ac power network 120 V – 60 Hz		Local ac power network 220 V – 50 or 60 Hz		Local ac power network 240 V – 50 Hz	
R_1 (Ω)	R_2 (Ω)	R_1 (Ω)	R_2 (Ω)	R_1 (Ω)	R_2 (Ω)
1200	1200	4400	4400	4800	4800
600	600	2200	2200	2400	2400
400	300	1467	1100	1600	1200
240	300	880	1100	960	1200
240	200	880	733	960	800
200	200	733	733	800	800
171	171	629	629	686	686

The results are presented in the following table.

Resistance values of R_1 and R_2 for various ac power networks.

Duty cycle (%)	Input voltage (V)	Output voltage (V)	Input current (A)	Output current (A)	Input power (W)	Output power (W)	Power efficiency (%)
45	49.93	255.7	0.313	0.000	15.87	0.00	0.00
45	50.00	234.2	0.770	0.101	38.86	23.61	60.75
45	50.00	231.5	1.184	0.192	59.82	44.38	74.19
45	50.02	230.0	1.834	0.332	93.00	76.35	82.09
45	50.02	229.3	2.267	0.428	115.1	98.22	85.34
45	49.90	227.9	2.715	0.521	137.5	118.7	86.30
45	50.05	228.2	2.928	0.571	148.6	130.4	87.74
45	49.98	227.1	3.375	0.667	170.8	151.4	88.64
25	50.00	256.8	0.323	0.000	16.29	0.00	0.00
25	49.96	236.5	0.775	0.102	38.95	23.99	61.59
25	50.03	229.8	1.168	0.191	58.82	43.85	74.55
25	49.96	226.6	1.797	0.328	90.61	74.30	81.99
25	49.94	224.7	2.238	0.420	113.0	94.44	83.57
25	50.05	223.4	2.671	0.511	135.2	114.0	84.34
25	49.94	222.2	2.882	0.557	145.5	123.7	84.98
25	49.98	220.7	3.292	0.648	166.1	143.0	86.07
15	50.00	243.8	0.254	0.000	12.66	0.00	0.00
15	49.95	229.7	0.699	0.100	34.85	22.89	65.67
15	49.97	225.6	1.102	0.188	54.98	42.31	76.95
15	49.95	219.9	1.719	0.319	85.81	70.22	81.54
15	49.95	216.3	2.125	0.405	106.0	87.56	82.57
15	49.91	212.8	2.520	0.486	125.8	103.5	82.31
15	49.95	211.3	2.708	0.530	135.3	111.9	82.73
15	49.95	208.0	3.086	0.611	154.2	127.1	82.42
5	50.04	240.2	0.218	0.000	10.85	0.00	0.00
5	49.95	213.0	0.636	0.092	31.71	19.59	62.09
5	49.99	197.3	0.963	0.164	48.10	32.34	67.24
5	50.01	178.5	1.384	0.258	69.23	46.13	66.63
5	49.99	167.8	1.612	0.315	80.60	52.87	65.59
5	50.04	159.1	1.806	0.365	90.43	58.04	64.18
5	49.95	154.7	1.896	0.388	94.76	60.06	63.38
5	49.95	147.2	2.046	0.434	102.3	63.81	62.37

16. In the **Data Table**, clear the recorded data without clearing the record settings.

Stop the **Insulated DC-to-DC Converter** by setting the **Status** parameter to **Stopped** or by clicking the **Start/Stop** button or in the **Chopper/Inverter Control** window.

On the **Resistive Load** module, set the resistance of resistors R_1 and R_2 to infinite.

Start the **Insulated DC-to-DC Converter** window by setting the **Status** parameter to **Started** or by clicking the **Start/Stop** button or in the **Chopper/Inverter Control** window.

In the **Chopper/Inverter Control** window, set the **Duty Cycle** parameter of the converter to each of the following values: 25%, 15%, and 5%. For each setting, repeat steps 15 and 16.

17. Stop the **Insulated DC-to-DC Converter** by setting the **Status** parameter to **Stopped** or by clicking the **Start/Stop** button or in the **Chopper/Inverter Control** window.

Save the data you transferred to the spreadsheet application.

Using this data, plot on the same graph the curves of the dc output voltage versus the output power for duty cycles of 45%, 25%, 15%, and 5%.

The resulting graph is shown below.

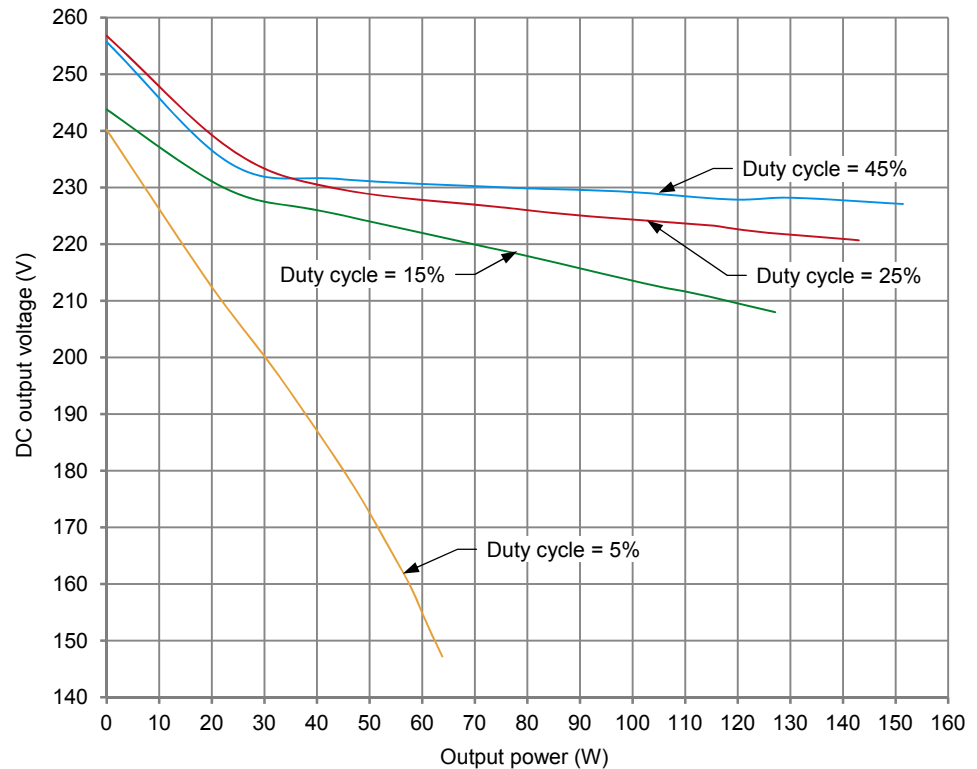

DC output voltage versus output power for duty cycles of 45%, 25%, 15%, and 5%.

18. Evaluate the voltage regulation of the dc-to-dc converter from the curves of the dc output voltage versus the output power obtained for duty cycles of 45%, 25%, 15%, and 5%.

The voltage regulation of the dc-to-dc converter is fairly good at duty cycles of 25% and 45%, though it becomes significantly worse at low load values (less than about 30 W). The voltage regulation of the dc-to-dc converter is rather poor at a duty cycle of 15%, and very poor at a duty cycle of 5%.

19. Would it be possible to improve voltage regulation? If so, explain how.

Yes. The curves of the dc output voltage versus the output power obtained for duty cycles of 45%, 25%, 15%, and 5% indicate that the output voltage, when set between 215 V and 230 V, approximately, can be maintained constant despite significant load variations by adjusting the duty cycle properly.

20. From the data exported to the spreadsheet application, plot on the same graph the curves of the power efficiency versus the output power for duty cycles of 45%, 25%, 15%, and 5%.

The resulting graph is shown below.

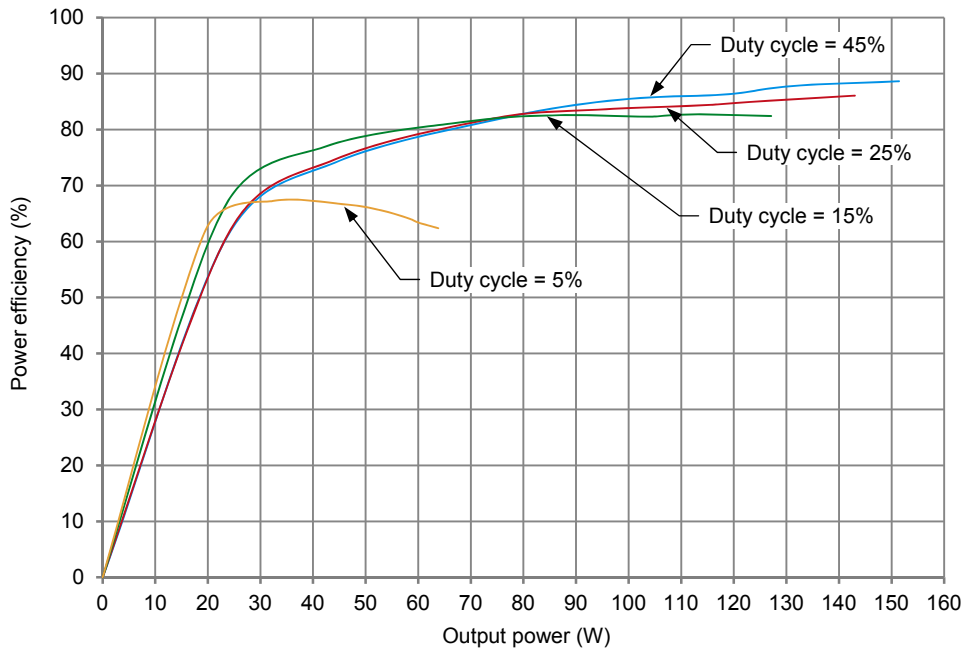

Power efficiency versus output power for duty cycles of 45%, 25%, 15%, and 5%.

21. Evaluate the power efficiency of the dc-to-dc converter from the curves of the power efficiency versus the output power obtained for duty cycles of 45%, 25%, 15%, and 5%.

The power efficiency of the dc-to-dc converter is good (between about 75% and 85%) at duty cycles of 15%, 25%, and 45%. The power efficiency of the dc-to-dc converter is significantly lower (about 65%) at a duty cycle of 5%. Also, the power efficiency of the dc-to-dc converter decreases rapidly at low load values (less than about 30 W) regardless of the duty cycle.

Regulating the output voltage using the duty cycle

In this part of the exercise, you will vary the load at the output of the Insulated DC-to-DC Converter while maintaining the output voltage constant by adjusting the duty cycle. You will plot a curve of the duty cycle versus the output power obtained when the output voltage of the Insulated DC-to-DC Converter is maintained constant while the load is varied. You will use this curve to observe how the duty cycle varies when the load at the output of the Insulated DC-to-DC Converter is varied.

22. Set the resistance of resistors R_1 and R_2 to the last combination of values shown in Table 1 (lowest load resistance value).

23. In the **Chopper/Inverter Control** window, set the duty cycle to 25%, then start the **Insulated DC-to-DC Converter**. Readjust the dc source voltage so that the dc voltage at the converter input is 50.0 V.
24. In the **Chopper/Inverter Control** window, adjust the duty cycle so that the dc output voltage is equal to the value given in Table 2. While doing so, readjust the dc source voltage so that the dc voltage at the converter input is 50.0 V, if necessary.

Table 2. Suggested DC output voltage for various local ac power networks.

Local ac power network		DC output voltage (V)
Voltage (V)	Frequency (Hz)	
120	60	225
220	50	450
240	50	450
220	60	450

25. In the **Data Table**, record the duty cycle of the converter, as well as the voltages, currents, and power at the input and output of the converter.

The results are presented in the following table.

Duty cycle of the converter, as well as voltages, currents, and power at the input and output of the converter, for different load resistance values.

Duty cycle (%)	Input voltage (V)	Output voltage (V)	Input current (A)	Output current (A)	Input power (W)	Output power (W)	Load resistance (Ω)
37	50	225.2	3.34	0.65	167.3	148.1	342
33	50	225.3	2.91	0.56	145.9	127.4	400
31	50	224.9	2.66	0.51	133.3	115.3	440
27	50	224.9	2.23	0.42	111.9	94.64	540
23	50	224.9	1.75	0.32	87.86	71.96	700
14	50	224.7	1.10	0.18	55.29	41.31	1200
6	50	223	0.64	0.09	32.12	20.13	2400

26. Successively set the resistance of resistors R_1 and R_2 to each of the other combinations of values shown in Table 1 to make the load resistance value increase by steps. For each load resistance value, repeat step 24 and step 25.
27. Stop the **Insulated DC-to-DC Converter**.

28. Do your results confirm that the voltage at the output of the **Insulated DC-to-DC Converter** can be maintained constant, by adjusting the duty cycle when the load varies (i.e., when the output power varies)?

Yes No

Yes

29. Plot a curve of the duty cycle versus the output power of the **Insulated DC-to-DC Converter** using the data recorded in the **Data Table**.

The resulting graph is shown below.

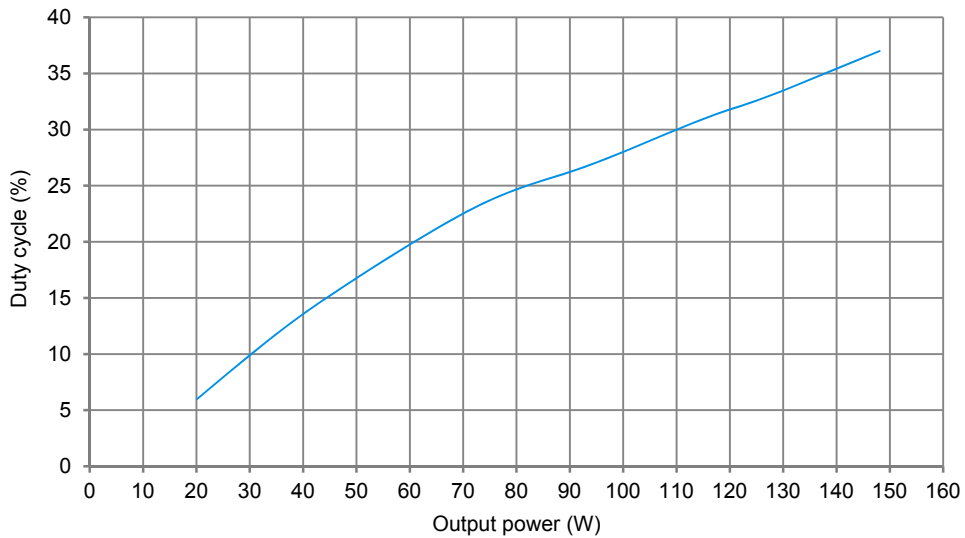

Duty cycle versus output power of the Insulated DC-to-DC Converter.

30. From the curve you plot in the previous step, describe how the duty cycle has to be varied to maintain the output voltage of the dc-to-dc converter constant when the load increases.

The duty cycle must be increased gradually to maintain the output voltage of the dc-to-dc converter constant when the load increases. For instance, the duty cycle goes from 10% to 35% almost linearly when the load increases from 30 W to 140 W and the output voltage is maintained at 225 V.

31. Close **LVDAC-EMS**, turn off all equipment, and remove all leads and cables.

CONCLUSION

In this exercise, you learned that HF transformers are used in switched-mode power supplies and insulated dc-to-dc converters, and that they are preferred to LF transformers because they are smaller, lighter, and cheaper. You also learned that an insulated dc-to-dc converter is identical to a switched-mode power supply except that it does not require a rectifier at the input because it is supplied with dc power. You saw that both the SMPS and insulated dc-to-dc converter provide electrical insulation between the input and output. You learned that many topologies are available to implement an SMPS or an insulated dc-to-dc converter using an HF power transformer. You became familiar with the operation of switched-mode power supplies and dc-to-dc converters by using a dc-to-dc converter implemented with the push-pull topology.

REVIEW QUESTIONS

1. What determines the nominal power of a power transformer?

The wire size and the saturation of the iron core respectively determine the nominal current and voltage of any power transformer, and thus, the nominal power of the transformer.

2. How can the voltage rating of the transformer windings be increased without changing the values of the maximum flux density B_{max} and magnetic field intensity H in the transformer?

Increasing the operating frequency allows the voltage rating of the transformer windings to be increased without changing the values of the maximum flux density B_{max} and magnetic field intensity H in the transformer (i.e., without moving the point of operation on the saturation curve of the transformer). For instance, doubling the operating frequency allows the nominal voltage to be doubled without changing the point of operation on the saturation curve of the transformer.

3. Explain why the duty cycle for each of the two transistors (Q_1 and Q_2) of the push pull converter shown in Figure 6 must be limited to about 0.45 (or 45%).

The duty cycle for each of the two transistors (Q_1 and Q_2) of the push pull converter shown in Figure 6 must be limited to about 0.45 (or 45%) to have a sufficient guard time ensuring that the two transistors cannot be on simultaneously.

4. What are the advantages of using HF power transformers in electrically powered equipment?

HF power transformers are commonly used in electrically powered equipment because they allow equipment size and weight to be reduced significantly, and also because they are cheaper than LF transformers having the same power rating.

5. What is the difference between a switched-mode power supply and an insulated dc-to-dc converter?

The insulated dc-to-dc converter is identical to an SMPS except that it does not require a rectifier at the input because it is supplied with dc power.

Bibliography

Billings, Keith, and Morey, Taylor, *Switchmode Power Supply Handbook*, 3rd Edition, United States of America: McGraw-Hill, 2011, ISBN 978-0-07-163971-2.

Kilgenstein, Otmar, *Switched-Mode Power Supplies in Practice*, Eastbourne: John Wiley & Sons, 1989, ISBN 978-0-47-192004-5.

Wildi, Theodore, *Electrical Machines, Drives, and Power Systems*, 6th Edition, Upper Saddle River: Prentice Hall, 2005, ISBN 978-0-13-177691-3.