

Electricity and New Energy

**Conventional DC Machines
and Universal Motor**

Courseware Sample

88943-F0

Order no.: 88943-10
First Edition
Revision level: 11/2014

By the staff of Festo Didactic

© Festo Didactic Ltée/Ltd, Quebec, Canada 2013, 2014
Internet: www.festo-didactic.com
e-mail: did@de.festo.com

Printed in Canada
All rights reserved
ISBN 978-2-89640-581-7 (Printed version)
ISBN 978-2-89640-582-4 (CD-ROM)
Legal Deposit – Bibliothèque et Archives nationales du Québec, 2014
Legal Deposit – Library and Archives Canada, 2014

The purchaser shall receive a single right of use which is non-exclusive, non-time-limited and limited geographically to use at the purchaser's site/location as follows.

The purchaser shall be entitled to use the work to train his/her staff at the purchaser's site/location and shall also be entitled to use parts of the copyright material as the basis for the production of his/her own training documentation for the training of his/her staff at the purchaser's site/location with acknowledgement of source and to make copies for this purpose. In the case of schools/technical colleges, training centers, and universities, the right of use shall also include use by school and college students and trainees at the purchaser's site/location for teaching purposes.

The right of use shall in all cases exclude the right to publish the copyright material or to make this available for use on intranet, Internet and LMS platforms and databases such as Moodle, which allow access by a wide variety of users, including those outside of the purchaser's site/location.

Entitlement to other rights relating to reproductions, copies, adaptations, translations, microfilming and transfer to and storage and processing in electronic systems, no matter whether in whole or in part, shall require the prior consent of Festo Didactic GmbH & Co. KG.

















Information in this document is subject to change without notice and does not represent a commitment on the part of Festo Didactic. The Festo materials described in this document are furnished under a license agreement or a nondisclosure agreement.

Festo Didactic recognizes product names as trademarks or registered trademarks of their respective holders.

All other trademarks are the property of their respective owners. Other trademarks and trade names may be used in this document to refer to either the entity claiming the marks and names or their products. Festo Didactic disclaims any proprietary interest in trademarks and trade names other than its own.

Safety and Common Symbols

The following safety and common symbols may be used in this manual and on the equipment:

Symbol	Description
	DANGER indicates a hazard with a high level of risk which, if not avoided, will result in death or serious injury.
	WARNING indicates a hazard with a medium level of risk which, if not avoided, could result in death or serious injury.
	CAUTION indicates a hazard with a low level of risk which, if not avoided, could result in minor or moderate injury.
	CAUTION used without the <i>Caution, risk of danger</i> sign  , indicates a hazard with a potentially hazardous situation which, if not avoided, may result in property damage.
	Caution, risk of electric shock
	Caution, hot surface
	Caution, risk of danger
	Caution, lifting hazard
	Caution, hand entanglement hazard
	Notice, non-ionizing radiation
	Direct current
	Alternating current
	Both direct and alternating current
	Three-phase alternating current
	Earth (ground) terminal

Safety and Common Symbols









Symbol	Description
	Protective conductor terminal
	Frame or chassis terminal
	Equipotentiality
	On (supply)
	Off (supply)
	Equipment protected throughout by double insulation or reinforced insulation
	In position of a bi-stable push control
	Out position of a bi-stable push control

Table of Contents

Preface	IX
About This Manual	XI
To the Instructor	XIII
Unit 1	Fundamentals of Rotating Machines 1
	DISCUSSION OF FUNDAMENTALS 1
	Basic motor operation 1
	The rotating electromagnet principle 3
	The generator principle 7
	Work, torque, and power 10
	Work..... 10
	Torque..... 11
	Power..... 12
	Electric motor efficiency 12
Ex. 1-1	Prime Mover and Brake Operation 15
	DISCUSSION..... 15
	Introduction to the Four-Quadrant Dynamometer/Power Supply..... 15
	Two-quadrant constant-torque brake 15
	Clockwise constant-speed prime mover/brake..... 16
	Counterclockwise constant-speed prime mover/brake..... 17
	Speed, torque, and mechanical power measurements using the Four-Quadrant Dynamometer/Power Supply 18
	Motor operation 18
	Generator operation 18
	PROCEDURE 19
	Set up and connections 19
	Two-quadrant, constant-torque brake operation 22
	Constant-speed prime mover operation 25
	Constant-speed prime mover driving a loaded generator 30
Unit 2	DC Motors and Generators 41
	DISCUSSION OF FUNDAMENTALS 41
	Operating principle of dc motors 41
	Operating principle of dc generators 45

Table of Contents

Ex. 2-1	The Separately-Excited DC Motor	49
	DISCUSSION.....	49
	Simplified equivalent circuit of a dc motor	49
	Relationship between the motor rotation speed and the armature voltage when the armature current is constant.....	51
	Relationship between the motor torque and the armature current	52
	Relationship between the motor rotation speed and the armature voltage when the armature current varies	52
	PROCEDURE	54
	Set up and connections.....	54
	Determining the armature resistance	57
	Motor speed versus armature voltage.....	58
	Motor torque versus armature current.....	61
	Speed decrease versus armature current.....	66
	Additional experiments (optional).....	70
	Motor speed-versus-armature voltage and motor torque- versus-armature current characteristics for reversed armature connections.....	70
Ex. 2-2	Separately-Excited, Series, Shunt, and Compound Motors	75
	DISCUSSION.....	75
	Separately-excited dc motor.....	75
	Series motor	77
	Shunt motor	78
	Compound motor.....	79
	PROCEDURE	81
	Set up and connections.....	81
	Speed-versus-armature voltage characteristic of a separately-excited dc motor	85
	Torque-versus-armature current characteristic of a separately-excited dc motor	88
	Speed-versus-torque characteristic of a series motor.....	92
	Additional experiments (optional).....	96
	Motor speed-versus-torque characteristic of a shunt motor	96
	Motor speed-versus-torque characteristic of a cumulative compound motor	99
Ex. 2-3	Separately-Excited, Shunt, and Compound DC Generators .	105
	DISCUSSION.....	105
	Introduction to dc generators.....	105
	Separately-excited dc generator	106
	Self-excited dc generator	108
	Voltage-versus-current characteristics of various dc generators	109

Table of Contents

	PROCEDURE	110
	Set up and connections	110
	Output voltage-versus-speed characteristic of a separately-excited dc generator	113
	Output current-versus-torque characteristic of a separately-excited dc motor	117
	Output voltage versus field current characteristic of a separately-excited dc generator	122
	Output voltage-versus-output current characteristic of a separately-excited dc generator operating at a fixed speed .	124
	Additional experiments (optional)	126
	Output voltage-versus-output current characteristic of a shunt generator operating at a fixed speed	126
	Voltage-versus-current characteristic of a cumulative- compound generator operating at a fixed speed	128
	Output voltage-versus-output current characteristic of a differential compound generator operating at a fixed speed	130
Unit 3	Special Characteristics of DC Motors.....	139
	DISCUSSION OF FUNDAMENTALS	139
Ex. 3-1	Armature Reaction and Saturation Effect	141
	DISCUSSION.....	141
	Armature reaction	141
	Saturation effect	144
	PROCEDURE	145
	Effect of the armature reaction on the output voltage of a dc generator	145
	Set up and connections	148
	Effect of the armature reaction on torque.....	151
	Effect of the saturation on torque	154
	Additional experiment (optional).....	161
	Effect of the armature reaction on the torque developed by a dc motor	161
Ex. 3-2	The Universal Motor	163
	DISCUSSION.....	163

Table of Contents

PROCEDURE	165
Set up and connections	166
Direction of rotation of a dc series motor.....	169
DC series motor operating on ac power.....	171
Direction of rotation of a universal motor operating on dc power	173
Universal motor operating on ac power.....	177
Effect of the compensating winding.....	179
Additional experiments (optional).....	181
Speed-versus-torque characteristic of an ac-powered universal motor.....	181
DC shunt motor operating on ac power.....	184
Appendix A Equipment Utilization Chart.....	191
Appendix B Glossary of New Terms	193
Appendix C Impedance Table for the Load Modules	197
Appendix D Circuit Diagram Symbols	199
Index of New Terms.....	205
Bibliography	207

Preface

The production of energy using renewable natural resources such as wind, sunlight, rain, tides, geothermal heat, etc., has gained much importance in recent years as it is an effective means of reducing greenhouse gas (GHG) emissions. The need for innovative technologies to make the grid smarter has recently emerged as a major trend, as the increase in electrical power demand observed worldwide makes it harder for the actual grid in many countries to keep up with demand. Furthermore, electric vehicles (from bicycles to cars) are developed and marketed with more and more success in many countries all over the world.

To answer the increasingly diversified needs for training in the wide field of electrical energy, the Electric Power Technology Training Program was developed as a modular study program for technical institutes, colleges, and universities. The program is shown below as a flow chart, with each box in the flow chart representing a course.

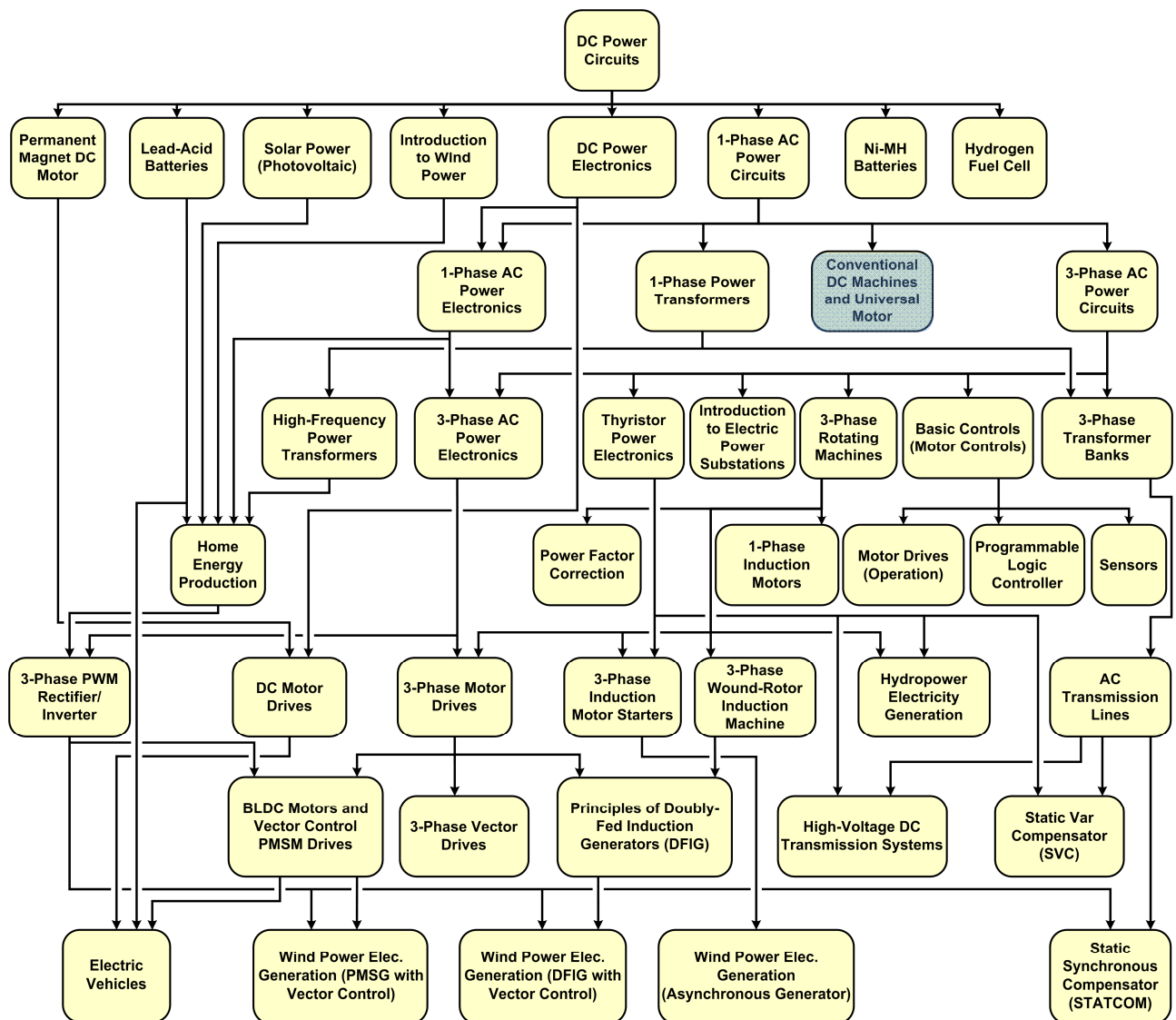

The Electric Power Technology Training Program.

Preface

The program starts with a variety of courses providing in-depth coverage of basic topics related to the field of electrical energy such as ac and dc power circuits, power transformers, rotating machines, ac power transmission lines, and power electronics. The program then builds on the knowledge gained by the student through these basic courses to provide training in more advanced subjects such as home energy production from renewable resources (wind and sunlight), large-scale electricity production from hydropower, large-scale electricity production from wind power (doubly-fed induction generator [DFIG], synchronous generator, and asynchronous generator technologies), smart-grid technologies (SVC, STATCOM, HVDC transmission, etc.), storage of electrical energy in batteries, and drive systems for small electric vehicles and cars.

Do you have suggestions or criticism regarding this manual?

If so, send us an e-mail at did@de.festo.com.

The authors and Festo Didactic look forward to your comments.

About This Manual

This course, *Conventional DC Machines and Universal Motor*, first describes the operation of the prime mover and brake used throughout the hands-on exercises. The student learns how to determine the polarity of the speed, torque, and mechanical power measured for a machine operating as either a motor or a generator. The course then introduces the student to the operation and characteristics of the following rotating machines: separately-excited, shunt, series, and compound dc motors, separately-excited, shunt, and compound dc generators, and universal motor. These machines, although still in use in numerous applications today, are less common in modern battery-powered applications (e.g., electric bicycles, mobility scooters, etc.) where power efficiency is at a premium.

Safety considerations

Safety symbols that may be used in this manual and on the equipment are listed in the Safety Symbols table at the beginning of the manual.

Safety procedures related to the tasks that you will be asked to perform are indicated in each exercise.

Make sure that you are wearing appropriate protective equipment when performing the tasks. You should never perform a task if you have any reason to think that a manipulation could be dangerous for you or your teammates.

Prerequisite

As a prerequisite to this course, you should have read the manuals titled *DC Power Circuits*, part number 86350 and *Single-Phase AC power Circuits*, part number 86358.

Systems of units

Units are expressed using the International System of Units (SI) followed by the units expressed in the U.S. customary system of units (between parentheses).

To the Instructor

You will find in this Instructor Guide all the elements included in the Student Manual together with the answers to all questions, results of measurements, graphs, explanations, suggestions, and, in some cases, instructions to help you guide the students through their learning process. All the information that applies to you is placed between markers and appears in red.

Accuracy of measurements

The numerical results of the hands-on exercises may differ from one student to another. For this reason, the results and answers given in this manual should be considered as a guide. Students who correctly performed the exercises should expect to demonstrate the principles involved and make observations and measurements similar to those given as answers.

Equipment installation

In order for students to be able to perform the exercises in the Student Manual, the Electric Power Technology Training Equipment must have been properly installed, according to the instructions given in the user guide Electric Power Technology Training Equipment, part number 38486-E.

Sample Exercise
Extracted from
the Student Manual
and the Instructor Guide

DC Motors and Generators

UNIT OBJECTIVE

When you have completed this unit, you will be able to use the DC Motor/Generator to demonstrate and explain the operation of dc motors and generators.

DISCUSSION OUTLINE

The Discussion of Fundamentals covers the following points:

- Operating principle of dc motors
- Operating principle of dc generators

DISCUSSION OF FUNDAMENTALS

Operating principle of dc motors

As stated in Unit 1, motors turn because of the interaction between two magnetic fields. This unit will discuss how these magnetic fields are produced in dc motors, and how magnetic fields induce voltage in dc generators.

The basic principle of a dc motor is the creation of a rotating magnet inside the mobile part of the motor, the rotor. This is accomplished by a device called the **commutator**, which is found on all dc machines. The commutator produces the alternating currents necessary for the creation of the rotating magnet from dc power provided by an external source. Figure 2-1 shows a typical dc motor rotor with its main parts. This figure shows that the electrical contact between the segments of the commutator and the external dc power source E_s is made through **brushes**. Note that the rotor of a dc motor is also referred to as the **armature**.

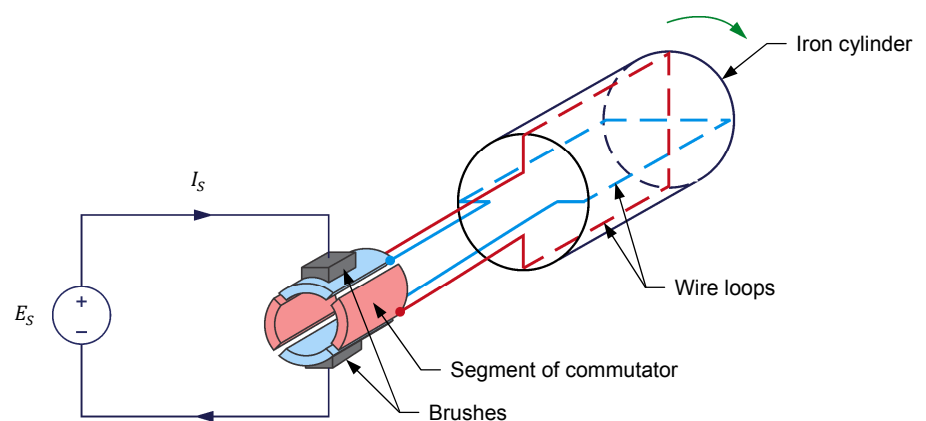

Figure 2-1. The main parts of a dc motor rotor (armature).

Figure 2-2 and Figure 2-3 show what happens to the magnetic field in the armature wire loops when the rotor of the dc motor in Figure 2-1 rotates. In Figure 2-2a, the brushes make contact with commutator segments A and B. Therefore, current flows from the dc power source to wire loop A-B via the brushes. No current flows in wire loop C-D. This creates an electromagnet A-B with north and south poles, as shown in Figure 2-2a. When the rotor is rotated clockwise a little as in Figure 2-2b, current still flows in wire loop A-B, and the north and south poles of the electromagnet are rotated clockwise.

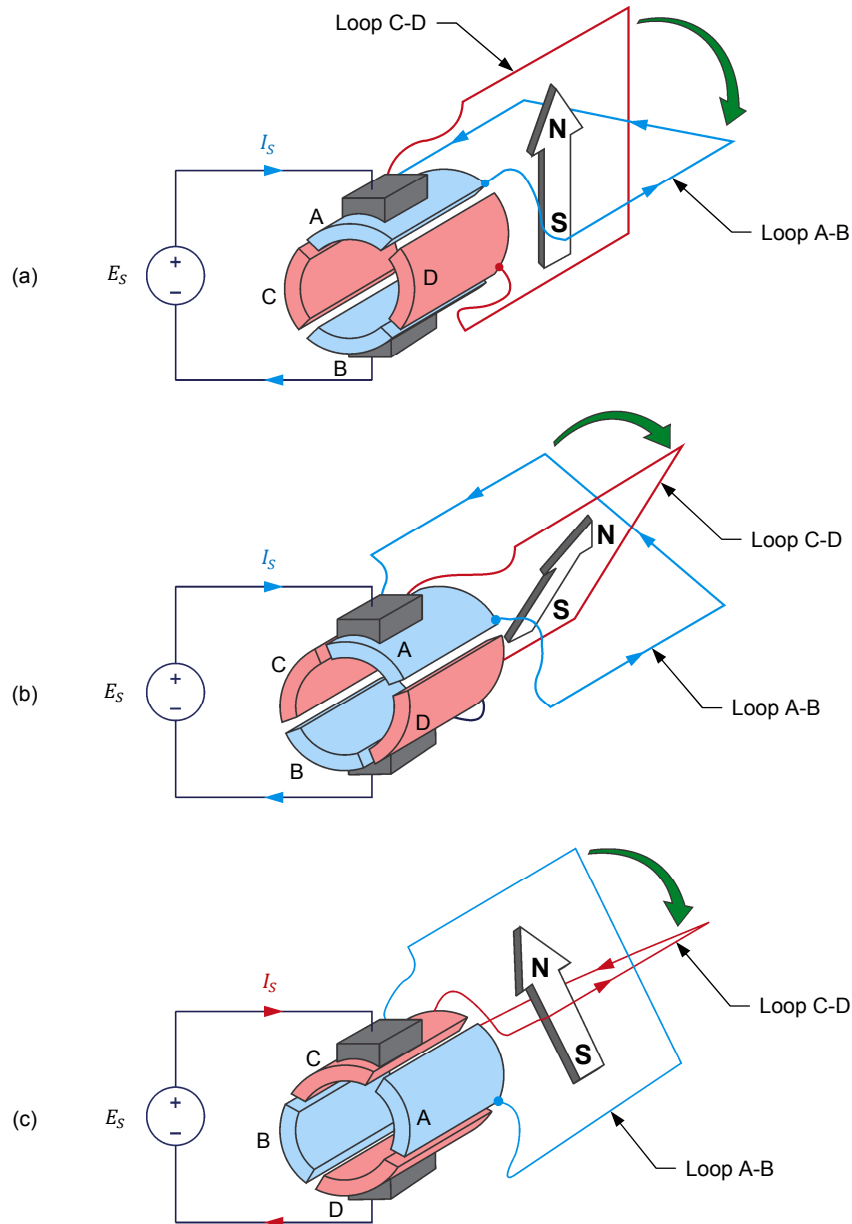

Figure 2-2. Magnetic field produced at the armature when the rotor rotates clockwise (part I).

As the rotor continues to rotate clockwise, the commutator slots pass by the brushes and a commutation occurs, i.e., the brushes stop making contact with commutator segments A and B and make contact with commutator segments C

and D instead, as shown in Figure 2-2c. Consequently, current stops flowing in wire loop A-B and starts to flow in wire loop C-D. This creates an electromagnet C-D with north and south poles, as shown in Figure 2-2c.

A comparison of Figure 2-2b and Figure 2-2c shows that, at commutation, the north and south poles of the electromagnet are rotated 90° counterclockwise. As the rotor continues to rotate clockwise, the same phenomenon repeats every 90° rotation (i.e., at every commutation), as shown in Figure 2-3.

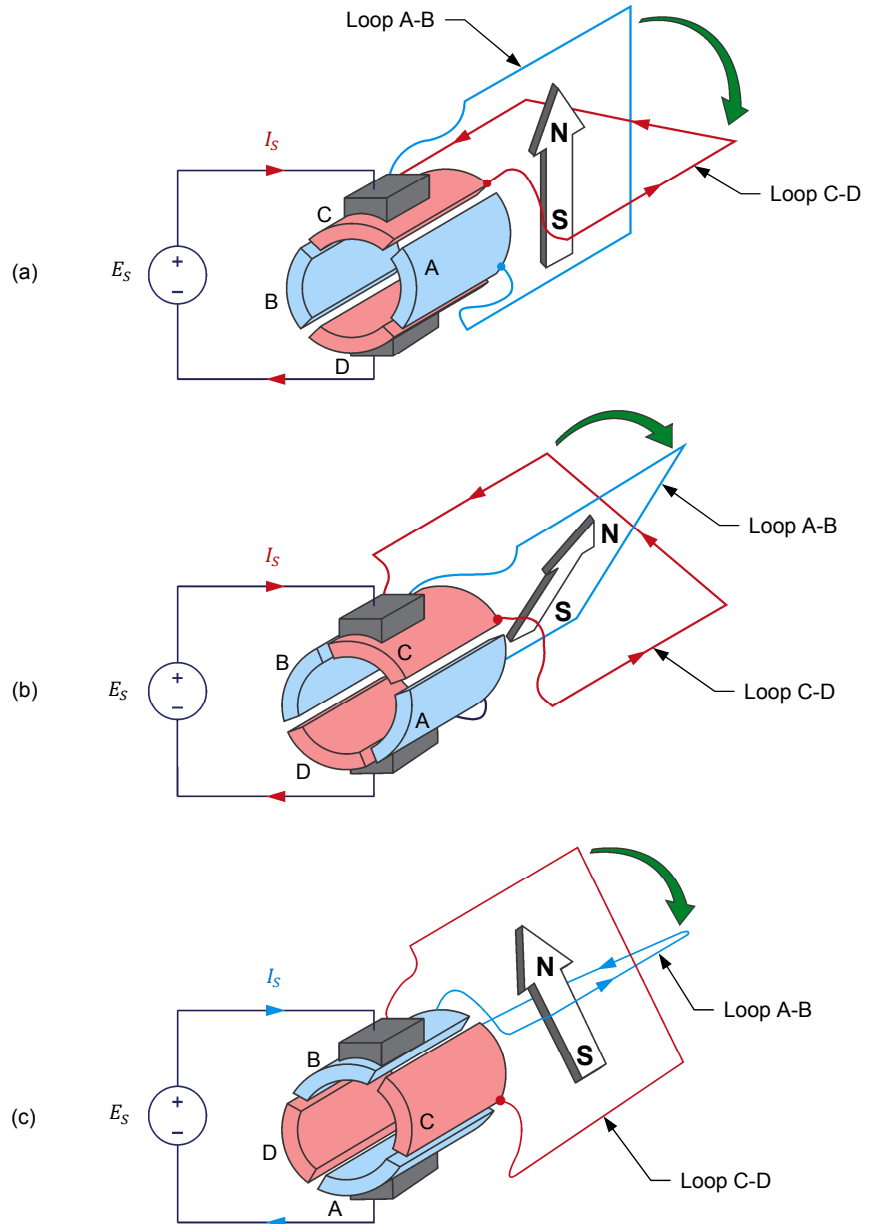

Figure 2-3. Magnetic field produced at the armature when the rotor rotates clockwise (part II).

In summary, as the rotor rotates, the north and south poles of the electromagnet go back and forth (oscillate) over a 90° angle, as Figure 2-4 shows. In other words, the north and south poles can be considered as stationary, i.e., they do not rotate as the rotor rotates. This is equivalent to having an electromagnet in the rotor that rotates at the same speed as the rotor, but in the opposite direction.

The higher the number of segments on the commutator, the lower the angle of rotation between each commutation, and thus, the lower the angle over which the north and south poles of the electromagnet oscillate. For example, if the commutator shown in Figure 2-1, Figure 2-2, and Figure 2-3 were having 32 segments instead of 4, the north and south poles would oscillate over an angle of only 11.25° instead of 90° .

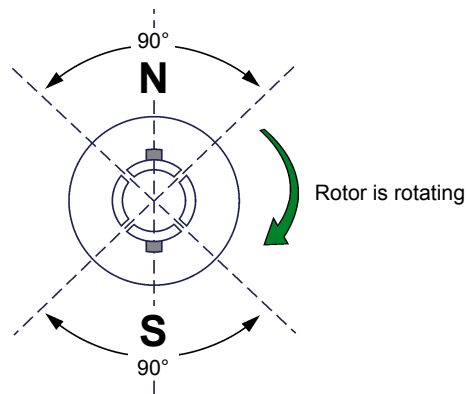

Figure 2-4. The north and south poles of the electromagnet at the armature oscillate around a fixed position.

When this rotor is placed next to a fixed permanent magnet **stator** as shown in Figure 2-5, the magnetic poles of opposite polarities attract each other (in order to align), while the magnetic poles of the same polarity repel each other, and the rotor starts to turn. After the rotor has turned by a certain angle, a commutation occurs and the north and south poles of the electromagnet go back to their initial location. Once again, the magnetic poles of opposite polarity attract each other (in order to align), while the magnetic poles of the same polarity repel each other, and the rotor starts to turn, and the rotor continues to rotate in the same direction. However, another commutation occurs a little after and the north and south poles of the electromagnet go back to their initial location once again. This cycle repeats over and over. The force that results from the interaction of the two magnetic fields always acts in the same direction, and the rotor turns continually. Thus, a rotating machine converting electrical energy into mechanical energy, i.e. an electric motor, is achieved. The direction of rotation depends on the polarity of the voltage applied to the brushes of the rotor.

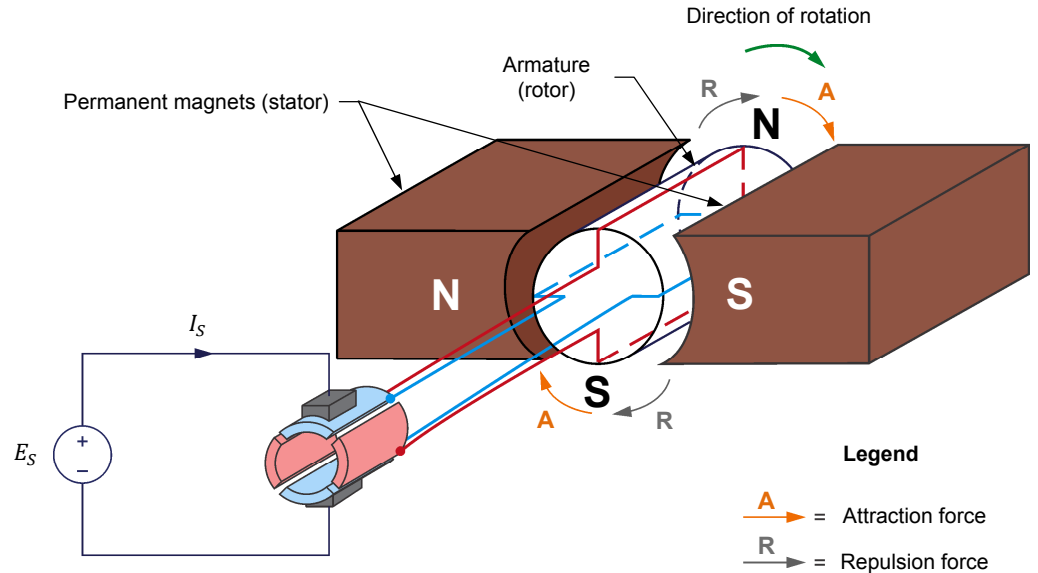

Figure 2-5. Rotation resulting from interaction of magnetic fields in the stator and the rotor.

Operating principle of dc generators

Previously, you saw that the variation of magnetic flux in a loop of wire causes a voltage to be induced across the ends of the loop. When a wire loop is placed between two magnets and rotated as shown in Figure 2-6, the magnetic flux ϕ that passes through the loop varies and a voltage, E_1 , is induced across the loop terminals. Voltage E_1 is collected by the two commutator segments and delivered to stationary brushes ($B+$ and $B-$) connected to the generator terminals.

- As the loop passes from position 0 to position 4, the magnetic flux ϕ in the loop passes from a negative maximum (maximum flux passing from the A side to the B side of the loop) to a positive maximum (maximum flux passing from the B side to the A side of the loop). During this 180° interval of rotation, the voltage E_1 induced across the loop has a positive polarity because the rate of change $\frac{\Delta\phi}{\Delta t}$ of the magnetic flux has a positive value.
- When the loop reaches position 4, the connections of the two commutator segments to brushes $B-$ and $B+$ are reversed. Consequently, this reverses the connections between the wire loop terminals and the generator terminals.
- As the loop passes from position 4 to position 0, the magnetic flux ϕ in the loop passes from a positive maximum (maximum flux passing from the B side to the A side of the loop) to a negative maximum (maximum flux passing from the A side to the B side of the loop). During this 180° interval of rotation, the voltage E_1 induced across the loop has a negative polarity because the rate of change $\frac{\Delta\phi}{\Delta t}$ of the magnetic flux has a negative value.
- When the loop reaches position 0, the connections of the two commutator segments to brushes $B-$ and $B+$ are reversed again, thereby

reversing the connections between the wire loop terminals and the generator terminals.

This cycle repeats as long as the rotor continues to rotate, so that the polarity of the voltage E_1 generated across the rotor wire loop continually alternates: it is positive for half a turn, then negative for the next half turn, then positive for the next half turn, and so on. Because of this, the voltage E_1 generated across the rotor wire loop is referred to as an alternating-current (ac) voltage. Because the commutator reverses the connections between the wire loop terminals and the generator terminals at wire loop positions 0 and 4, the voltage E_2 at the generator terminals always has the same polarity (positive), as is shown in Figure 2-6. The voltage E_2 at the generator terminals is thus a pulsating positive direct current (dc) voltage (two pulses per rotation).

The faster the speed of rotation of the rotor, the higher the rate of change of the magnetic flux ϕ passing through the wire loop, and therefore, the higher the voltage E_2 at the generator terminals. Also, the stronger the magnetic field of the permanent magnet, the higher the intensity of the magnetic flux, and therefore, the higher the voltage E_2 at the generator terminals.

In Figure 2-6, the A side of the wire loop designates the plane of the loop viewed from the north (N) pole, while the B side of the wire loop designates the plane of the loop viewed from the south (S) pole.

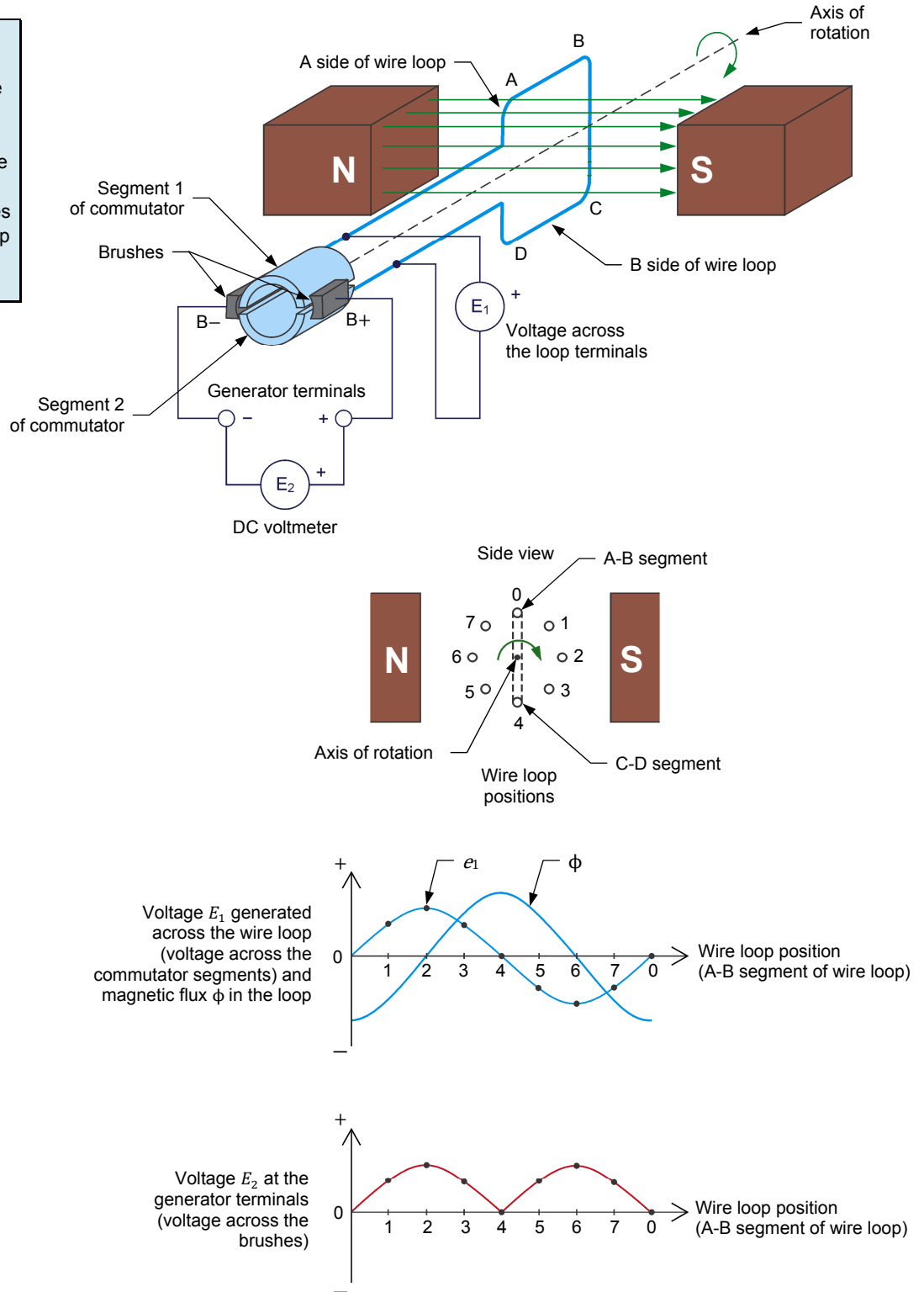

Figure 2-6. A wire loop rotating in a magnetic field results in an induced voltage (clockwise rotation).

When the direction of rotation of the wire loop is reversed, the polarity of the dc voltage E_2 at the generator terminals also reverses, as Figure 2-7 shows. The voltage E_2 at the generator terminals is thus a pulsating negative dc voltage (two pulses per rotation).

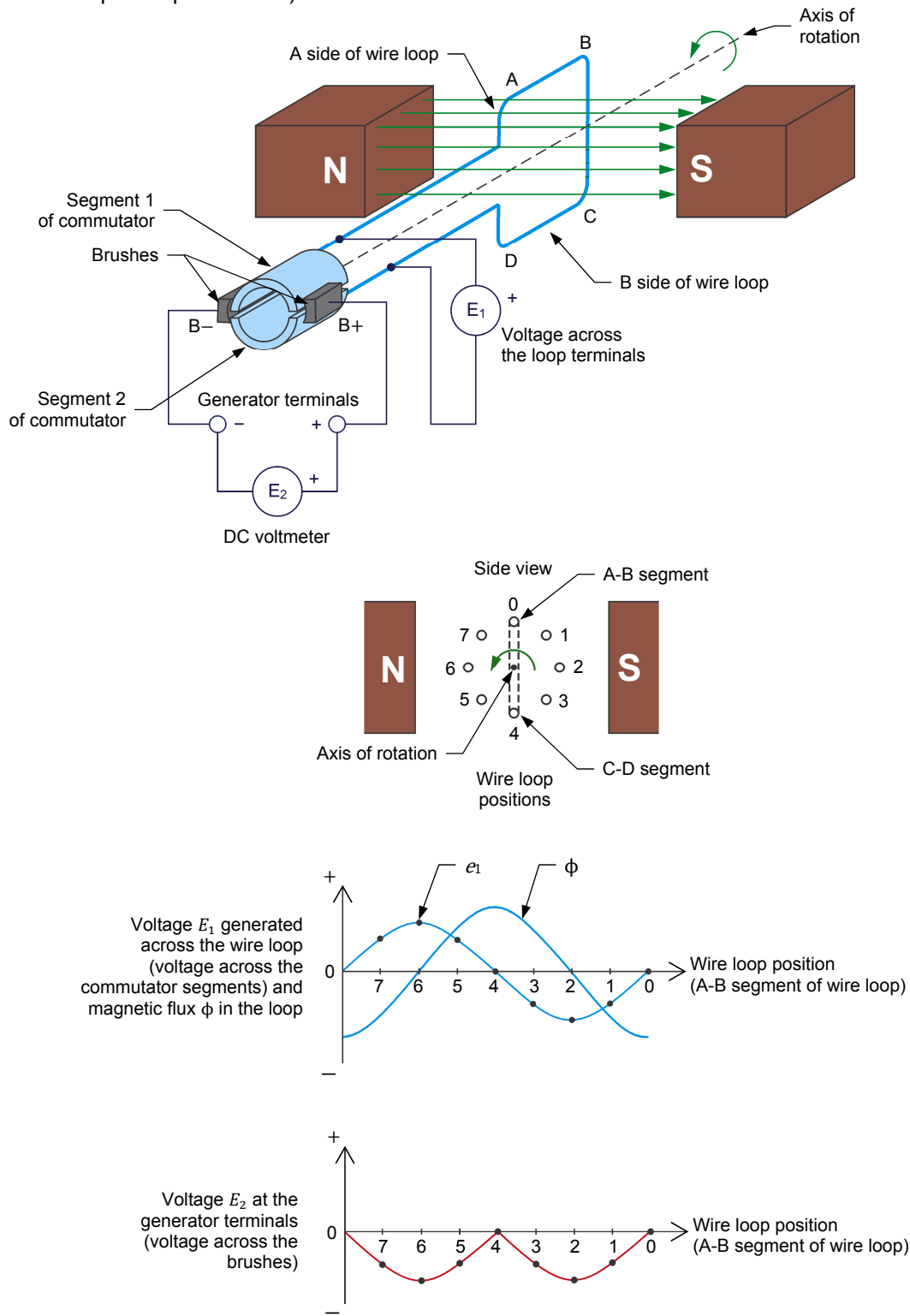

Figure 2-7. When the direction of rotation of the wire loop is reversed, the polarity of the dc voltage at the generator terminals also reverses.

The Separately-Excited DC Motor

EXERCISE OBJECTIVE

When you have completed this exercise, you will be able to demonstrate the main operating characteristics of a separately-excited dc motor using the DC Motor/Generator.

DISCUSSION OUTLINE

The Discussion of this exercise covers the following points:

- Simplified equivalent circuit of a dc motor
- Relationship between the motor rotation speed and the armature voltage when the armature current is constant
- Relationship between the motor torque and the armature current
- Relationship between the motor rotation speed and the armature voltage when the armature current varies

DISCUSSION

Simplified equivalent circuit of a dc motor

Previously, you saw that a dc motor is made up of a fixed magnet (stator) and a rotating magnet (rotor). Many dc motors use an electromagnet at the stator, as Figure 2-8 shows.

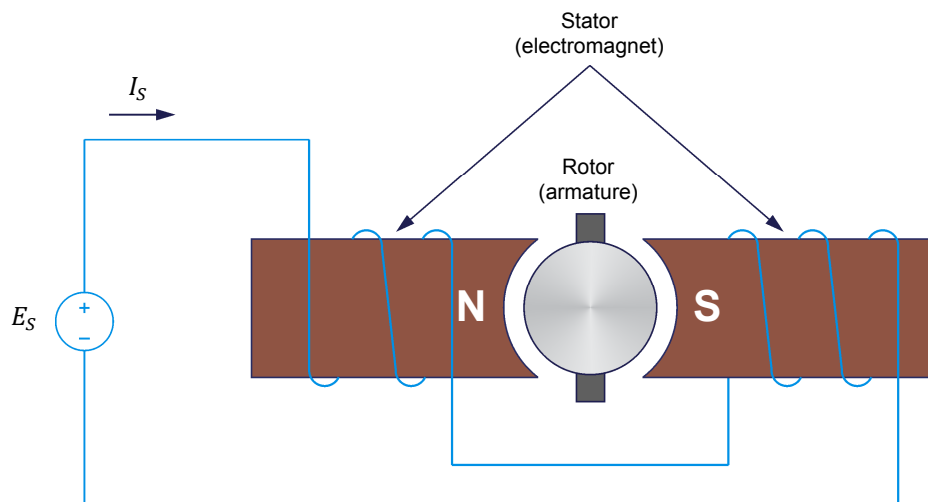

Figure 2-8. Simplified dc motor using an electromagnet as stator.

When power for the stator electromagnet is supplied by a separate dc source, of either fixed or variable voltage, the motor is known as a **separately-excited dc motor**. Sometimes the term independent-field dc motor is also used. The

current flowing in the stator electromagnet is often called **field current** because it is used to create a fixed magnetic field.

The electrical and mechanical behavior of the dc motor can be understood by examining its simplified equivalent electric circuit shown in Figure 2-9.

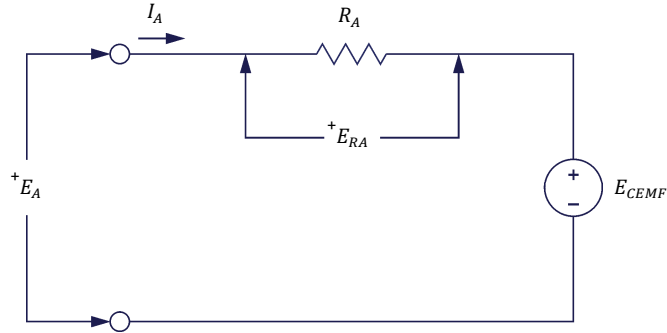

Figure 2-9. Simplified equivalent circuit of a dc motor.

In the circuit, E_A is the voltage applied to the motor brushes, I_A is the current flowing in the armature through the brushes, and R_A is the resistance between the brushes. Note that E_A , I_A , and R_A are usually referred to as the armature voltage, current, and resistance, respectively. E_{RA} is the voltage drop across the armature resistor. When the motor turns, an induced voltage E_{CEMF} proportional to the speed of the motor is produced. This induced voltage is represented by a dc source in the simplified equivalent circuit of Figure 2-9. The motor also develops a torque T proportional to the armature current I_A flowing in the motor. The motor behavior is based on the two equations given below. Equation (2-1) relates motor speed n and the induced voltage E_{CEMF} . Equation (2-2) relates the motor torque T and the armature current I_A .

$$n = K_1 \cdot E_{CEMF} \quad (2-1)$$

where n is the motor rotation speed, expressed in revolutions per minute (r/min).

K_1 is a constant expressed in $\frac{r/min}{V}$.

E_{CEMF} is the voltage induced across the armature, expressed in volts (V).

$$T = K_2 \cdot I_A \quad (2-2)$$

where T is the motor torque, expressed in newton-meters (N·m) or in pound-force inches (lbf·in).

K_2 is a constant expressed in $\frac{N \cdot m}{A}$ or $\frac{lbf \cdot in}{A}$.

I_A is the armature current, expressed in amperes (A).

Relationship between the motor rotation speed and the armature voltage when the armature current is constant

When a voltage E_A is applied to the armature of a dc motor with no mechanical load, the armature current I_A flowing in the equivalent circuit of Figure 2-9 is constant and has a very low value. As a result, the voltage drop E_{RA} across the armature resistor is so low that it can be neglected, and E_{CEMF} can be considered to be equal to the armature voltage E_A . Therefore, the relationship between the motor rotation speed n and the armature voltage E_A is a straight line because E_{CEMF} is proportional to the motor rotation speed n . This linear relationship is shown in Figure 2-10. The slope of the straight line equals constant K_1 .

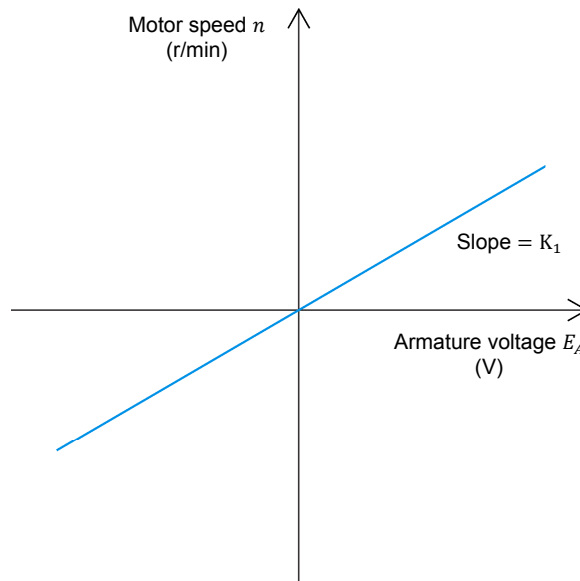

Figure 2-10. Linear relationship between the motor rotation speed and the armature voltage.

Since the relationship between voltage E_A and the rotation speed n is linear, a dc motor can be considered to be a linear voltage-to-speed converter, as shown in Figure 2-11.

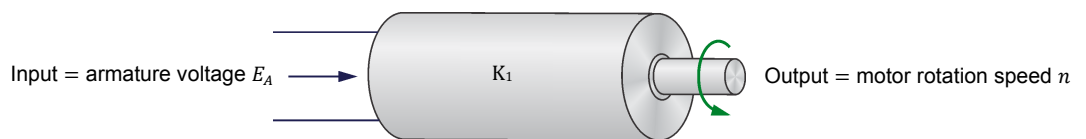

Figure 2-11. DC motor as a voltage-to-speed converter.

Relationship between the motor torque and the armature current

The same type of relationship exists between the motor torque T and the armature current I_A , so that a dc motor can also be considered as a linear current-to-torque converter. Figure 2-12 illustrates the linear relationship between the motor torque T and the armature current I_A . Constant K_2 is the slope of the line relating the two. The linear current-to-torque converter is shown in Figure 2-13.

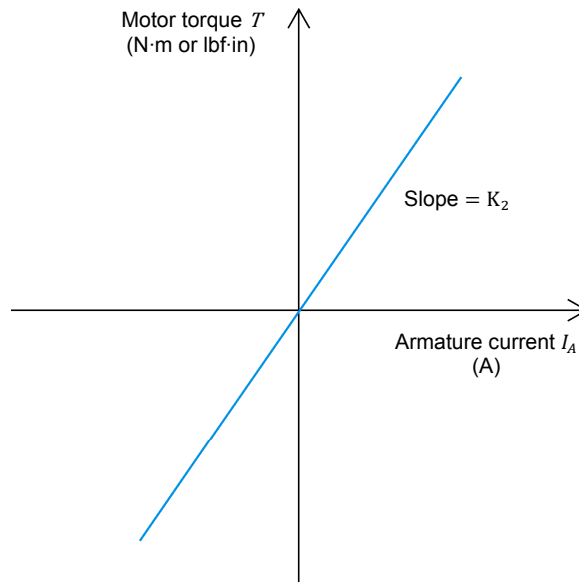

Figure 2-12. Linear relationship between the motor torque and the armature current.

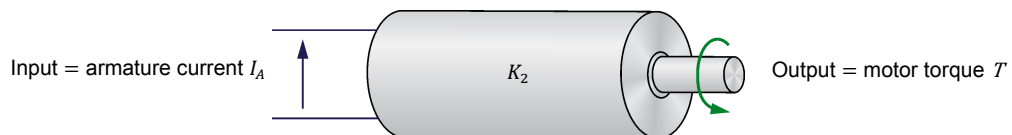

Figure 2-13. DC motor as a current-to-torque converter.

Relationship between the motor rotation speed and the armature voltage when the armature current varies

When the armature current I_A increases, the voltage drop E_{RA} ($R_A \cdot I_A$) across the armature resistor also increases and can no longer be neglected. As a result, the armature voltage E_A can no longer be considered equal to E_{CEMF} , but rather the sum of E_{CEMF} and E_{RA} , as Equation (2-3) shows:

$$E_A = E_{CEMF} + E_{RA} \quad (2-3)$$

Therefore, when a fixed armature voltage E_A is applied to a dc motor, the voltage drop E_{RA} across the armature resistor increases as the armature current I_A increases, and thereby, causes E_{CEMF} to decrease. This also causes the motor rotation speed n to decrease because it is proportional to E_{CEMF} . This is shown in Figure 2-14, which is a graph of the motor rotation speed n versus the armature current I_A for a fixed armature voltage E_A .

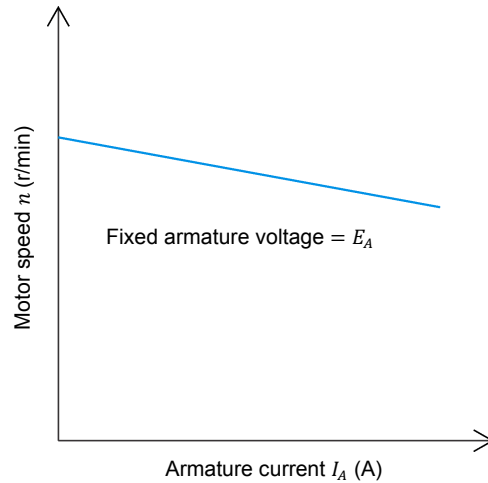

Figure 2-14. The motor rotation speed drops as the armature current increases (fixed armature voltage E_A).



Figure 2-15. Example of a separately-excited dc motor used in a racing kart.

PROCEDURE OUTLINE

The Procedure is divided into the following sections:

- Set up and connections
- Determining the armature resistance
- Motor speed versus armature voltage
- Motor torque versus armature current
- Speed decrease versus armature current
- Additional experiments (optional)
Motor speed-versus-armature voltage and motor torque-versus-armature current characteristics for reversed armature connections.

PROCEDURE

WARNING



High voltages are present in this laboratory exercise. Do not make or modify any banana jack connections with the power on unless otherwise specified.

Set up and connections

In this section, you will mechanically couple the DC Motor/Generator to the Four-Quadrant Dynamometer/Power Supply and set up the equipment.

1. Refer to the Equipment Utilization Chart in Appendix A to obtain the list of equipment required to perform the exercise. Install the equipment in the [Workstation](#).



Before performing the exercise, ensure that the brushes of the DC Motor/Generator are adjusted to the neutral point. To do so, connect a variable-voltage ac power source (terminals 4 and N of the [Power Supply](#)) to the armature of the DC Motor/Generator (terminals 1 and 2) through current input I1 of the [Data Acquisition and Control Interface \(DACI\)](#). Connect the shunt winding of the DC Motor/Generator (terminals 5 and 6) to voltage input E1 of the DACI. In [LVDAC-EMS](#), open the [Metering](#) window. Set two meters to measure the rms values (ac) of the armature voltage E_A and armature current I_A at inputs E1 and I1 of the DACI, respectively. Turn the [Power Supply](#) on and adjust its voltage control knob so that an ac current (indicated by meter I1 in the [Metering](#) window) equal to half the nominal armature current flows in the armature of the DC Motor/Generator. Adjust the brush adjustment lever on the DC Motor/Generator so that the voltage across the shunt winding (indicated by meter E1 in the [Metering](#) window) is minimal. Turn the [Power Supply](#) off, close [LVDAC-EMS](#), and disconnect all leads and cable.

Mechanically couple the [DC Motor/Generator](#) to the [Four-Quadrant Dynamometer/Power Supply](#) using a timing belt.

WARNING



Before coupling rotating machines, make absolutely sure that power is turned off to prevent any machine from starting inadvertently.

2. Make sure that the main power switch of the **Four-Quadrant Dynamometer/Power Supply** is set to the **O** (off) position, then connect its **Power Input** to an ac power wall outlet.
3. On the **Power Supply**, make sure that the main power switch and the 24 V ac power switch are set to the **O** (off) position, and that the voltage control knob is set to 0% (turned fully counterclockwise). Connect the **Power Supply** to a three-phase ac power outlet.
4. Connect the **Power Input** of the **Data Acquisition and Control Interface** (DACI) to the 24 V ac power source of the **Power Supply**.

Turn the 24 V ac power source of the **Power Supply** on.

5. Connect the USB port of the **Data Acquisition and Control Interface** to a USB port of the host computer.

Connect the USB port of the **Four-Quadrant Dynamometer/Power Supply** to a USB port of the host computer.

6. Connect the equipment as shown in Figure 2-16. Use the variable dc voltage output of the **Power Supply** to implement the variable-voltage dc power source E_s . Use the fixed dc voltage output of the **Power Supply** to implement the fixed-voltage dc power source. $E1$, $I1$ and $I2$ are voltage and current inputs of the **Data Acquisition and Control Interface** (DACI). Leave the circuit open at points A and B shown in the figure.
7. On the **Four-Quadrant Dynamometer/Power Supply**, set the **Operating Mode** switch to **Dynamometer**. This setting allows the **Four-Quadrant Dynamometer/Power Supply** to operate as a prime mover, a brake, or both, depending on the selected function.

Turn the **Four-Quadrant Dynamometer/Power Supply** on by setting the main power switch to the **I** (on) position.

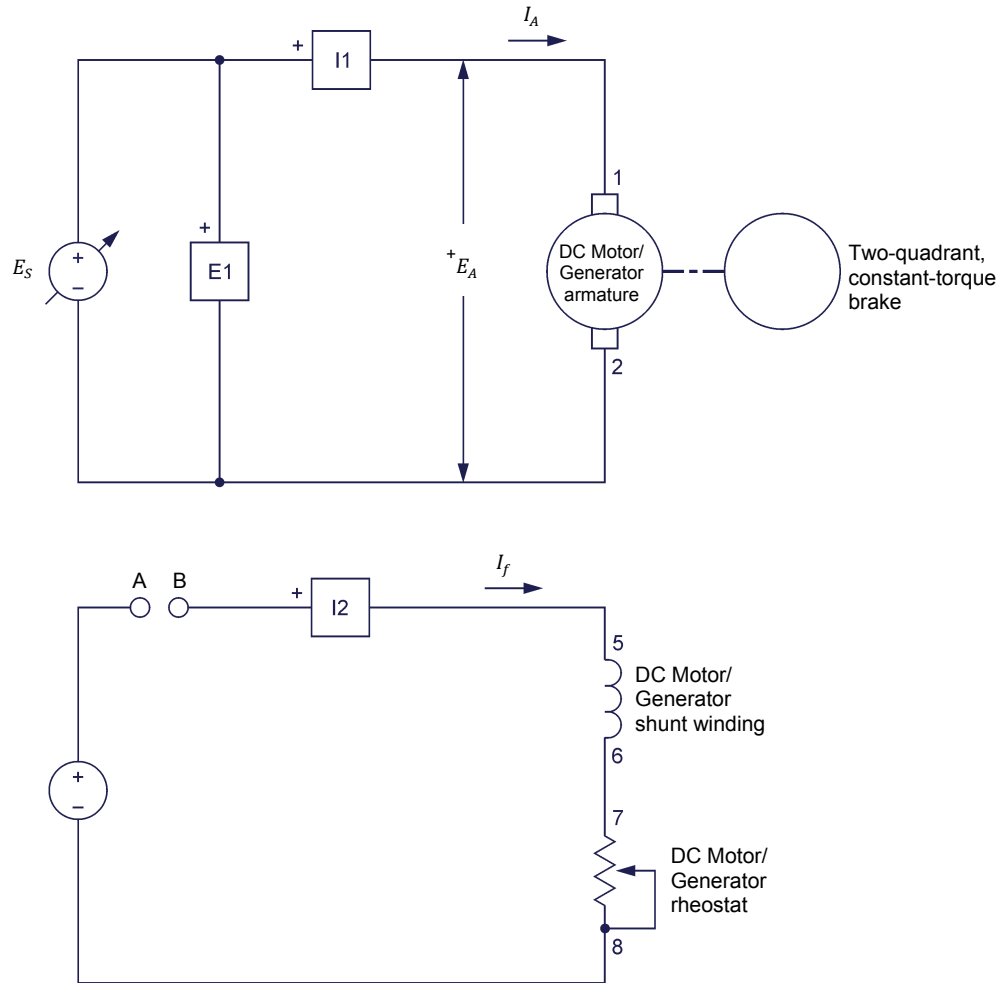



Figure 2-16. Separately-excited dc motor coupled to a brake.

8. Turn the host computer on, then start the LVDAC-EMS software.

In the LVDAC-EMS Start-Up window, make sure that the Data Acquisition and Control Interface and the Four-Quadrant Dynamometer/Power Supply are detected. Make sure that the Computer-Based Instrumentation function is available for the Data Acquisition and Control Interface module. Select the network voltage and frequency that correspond to the voltage and frequency of the local ac power network, then click the OK button to close the LVDAC-EMS Start-Up window.

9. In LVDAC-EMS, open the **Four-Quadrant Dynamometer/Power Supply** window, then make the following settings:
 - Set the **Function** parameter to *Two-Quadrant, Constant-Torque Brake*. This setting makes the **Four-Quadrant Dynamometer/Power Supply** operate as a two-quadrant brake with a torque setting corresponding to the **Torque** parameter.
 - Set the **Pulley Ratio** parameter to 24:24. The first and second numbers in this parameter specify the number of teeth on the pulley of the **Four-Quadrant Dynamometer/Power Supply** and the number of teeth on the pulley of the machine under test (i.e., the **DC Motor/Generator**), respectively.
 - Make sure that the **Torque Control** parameter is set to *Knob*. This allows the torque of the two-quadrant brake to be controlled manually.
 - Set the **Torque** parameter to the maximum value (3.0 N·m or 26.5 lbf·in). This sets the torque command of the *Two-Quadrant, Constant-Torque Brake* to 3.0 N·m (26.5 lbf·in).

 The torque command can also be set by using the **Torque** control knob in the **Four-Quadrant Dynamometer/Power Supply** window.

 - Start the *Two-Quadrant, Constant-Torque Brake* by setting the **Status** parameter to *Started* or by clicking the **Start/Stop** button.

10. In LVDAC-EMS, open the **Metering** window. Set two meters to measure the dc motor armature voltage E_A (**E1**) and armature current I_A (**I1**). Set a meter to measure the dc motor armature resistance R_A [**RDC (E1, I1)**]. Finally, set a meter to measure the dc motor field current I_f (**I2**).

Click the **Continuous Refresh** button to enable continuous refresh of the values indicated by the various meters in the **Metering** application.

Determining the armature resistance

In this section, you will measure the armature resistance R_A of the DC Motor/Generator. It is not possible to measure the armature resistance R_A of the DC Motor/Generator with a conventional ohmmeter because the non-linear characteristic of the motor brushes causes incorrect results when the armature current I_A is too low. The general method used to measure R_A consists in connecting a dc power source to the motor armature and measuring the voltage required to make nominal current flow in the armature windings. No power source is connected to the motor stator to ensure that the motor does not rotate, and that E_{CEMF} equals zero. The ratio of the armature voltage E_A to the armature current I_A yields the armature resistance R_A directly.



The motor will not start rotating because it is mechanically loaded.

11. Turn the **Power Supply** on by setting the main power switch to the I (on) position. Set the voltage control knob of the **Power Supply** so that the armature current I_A (indicated by meter **I1** in the **Metering** window) flowing in the **DC Motor/Generator** is equal to the rated armature current.



The rating of any of the supplied machines is indicated in the lower section of the module front panel.

Record the value of the armature resistance R_A [indicated by meter **RDC (E1, I1)** in the **Metering** window].

Armature resistance $R_A = \underline{\hspace{2cm}} \Omega$

Armature resistance $R_A \cong 7.6 \Omega$

12. On the **Power Supply**, set the voltage control knob to 0%, then set the main power switch to the O (off) position. (Leave the 24 V ac power source of the **Power Supply** turned on.)

Interconnect points A and B in the circuit of Figure 2-16.

Motor speed versus armature voltage

In this section, you will measure data and plot a graph of the separately-excited dc motor speed n as a function of the armature voltage E_A to demonstrate that the motor speed is proportional to the armature voltage under no-load conditions.

13. In **LVDAC-EMS**, open the **Data Table** window. Set the **Data Table** to record the dc motor rotation speed n and torque T (indicated by the **Speed** and **Torque** meters in the **Four-Quadrant Dynamometer/Power Supply** window), as well as the dc motor armature voltage E_A , armature current I_A , and field current I_f (indicated by meters **E1**, **I1**, and **I2** in the **Metering** window).
14. In the **Four-Quadrant Dynamometer/Power Supply** window, set the **Torque** parameter to 0.0 N·m (or 0.0 lbf·in).
15. Turn the **Power Supply** on by setting the main power switch to the I (on) position.

On the **DC Motor/Generator**, set the **Field Rheostat** knob so that the field current I_f (indicated by meter **I2** in the **Metering** window) is equal to the value indicated in Table 2-1 for your local ac power network.

Table 2-1. Field current I_f .

Local ac power network		Field current I_f (mA)
Voltage (V)	Frequency (Hz)	
120	60	300
220	50	190
240	50	210
220	60	190

- On the **Power Supply**, vary the voltage control knob setting from 0% to 100% in 10% steps in order to increase the armature voltage E_A by steps. For each setting, wait until the motor speed stabilizes, then record the motor armature voltage E_A , armature current I_A , and field current I_f , as well as the motor rotation speed n and torque T in the **Data Table**.
- When all data has been recorded, stop the **DC Motor/Generator** by setting the voltage control knob to 0% and the main power switch of the **Power Supply** to the O (off) position. (Leave the 24 V ac power source of the **Power Supply** turned on.)

In the **Data Table** window, confirm that the data has been stored, save the data table under filename DT211, and print the data table if desired.

The results obtained are presented below.

Armature voltage, armature current, field current, rotation speed, and torque of the separately-excited dc motor (DT211).

Motor armature voltage E_A (V)	Motor armature current I_A (A)	Motor field current I_f (A)	Motor speed n (r/min)	Motor torque T (N·m or lbf-in)
0.00	0.00	0.300	0	0.00 N·m (0.00 lbf-in)
14.15	0.443	0.300	146	0.20 N·m (1.77 lbf-in)
27.71	0.512	0.299	326	0.22 N·m (1.95 lbf-in)
41.66	0.550	0.298	511	0.25 N·m (2.21 lbf-in)
55.49	0.592	0.298	694	0.28 N·m (2.48 lbf-in)
68.55	0.609	0.297	866	0.30 N·m (2.48 lbf-in)

Motor armature voltage E_A (V)	Motor armature current I_A (A)	Motor field current I_f (A)	Motor speed n (r/min)	Motor torque T (N·m or lbf·in)
82.27	0.640	0.297	1051	0.31 N·m (2.66 lbf·in)
96.17	0.651	0.297	1232	0.31 N·m (2.74 lbf·in)
109.7	0.678	0.296	1406	0.32 N·m (2.83 lbf·in)
124.4	0.686	0.296	1592	0.33 N·m (2.92 lbf·in)
138.3	0.695	0.297	1764	0.35 N·m (3.10 lbf·in)

18. In the Graph window, make the appropriate settings to obtain a graph of the dc motor speed n as a function of the armature voltage E_A . Name the graph "G211", name the x-axis "Armature voltage", name the y-axis "Motor speed", and print the graph if desired.

The resulting graph is shown below.

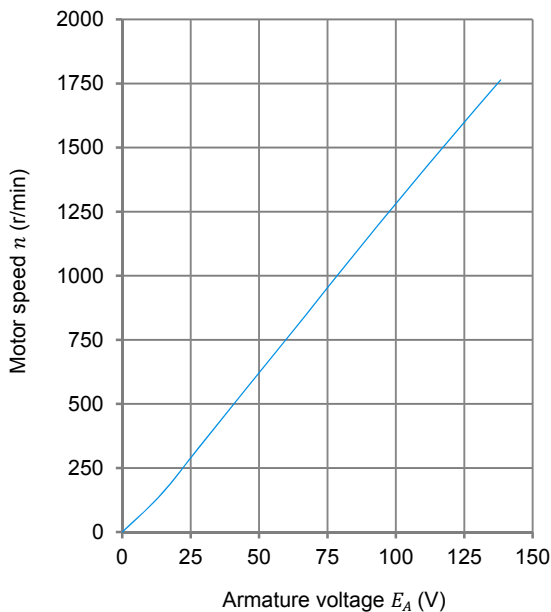

Separately-excited dc motor speed n versus armature voltage E_A (G211).

What kind of relationship exists between the armature voltage E_A and dc motor speed n ?

A linear relationship (see figure above)

Does this graph confirm that the separately-excited dc motor is equivalent to a linear voltage-to-speed converter, with higher voltage producing greater speed?

Yes No

Yes

19. Use the two end points to calculate the slope K_1 of the relationship obtained in graph G211. The values of these points are indicated in data table DT211.

$$K_1 = \frac{n_2 - n_1}{E_2 - E_1} = \frac{-}{-} = \frac{\text{r/min}}{\text{V}}$$

$$K_1 = \frac{n_2 - n_1}{E_2 - E_1} = \frac{1764 \text{ r/min} - 0 \text{ r/min}}{138 \text{ V} - 0 \text{ V}} = 12.9 \frac{\text{r/min}}{\text{V}}$$

20. In the **Data Table** window, clear the recorded data.

Motor torque versus armature current

In this section, you will measure data and plot a graph of the separately-excited dc motor torque T as a function of the armature current I_A to demonstrate that the motor torque is proportional to the armature current.

21. In the **Four-Quadrant Dynamometer/Power Supply** window, make sure that the **Torque** parameter is set to 0.0 N·m (0.0 lbf·in).
22. Turn the **Power Supply** on by setting the main power switch to the I (on) position.

On the **DC Motor/Generator**, slightly readjust the **Field Rheostat** knob, if necessary, so that the field current I_f (indicated by meter **I2** in the **Metering** window) is equal to the value indicated in Table 2-1 for your local ac power network.

On the **Power Supply**, set the voltage control knob so that the motor rotation speed n is 1500 r/min. Note and record the value of the motor armature voltage E_A (**E1**).

Armature voltage E_A ($n = 1500 \text{ r/min}$) = _____ V

Motor armature voltage E_A ($n = 1500 \text{ r/min}$) = 117 V

Note and record the value of the motor torque T indicated by the *Torque* meter in the *Four-Quadrant Dynamometer/Power Supply*.

Motor torque T (minimum) = _____ N·m (lbf·in)

Motor torque T (minimum) = 0.33 N·m (2.9 lbf·in)

- 23.** In the *Four-Quadrant Dynamometer/Power Supply* window, set the *Torque* parameter to the minimum value measured in step 22. Record the motor rotation speed n and torque T , as well as the motor armature voltage E_A , armature current I_A , and field current I_f in the *Data Table*.

Increase the *Torque* parameter from the minimum value to about 1.9 N·m (about 16.8 lbf·in) if your local ac power network voltage is 120 V, or from the minimum value to about 2.3 N·m (about 20.4 lbf·in) if your local ac power network voltage is 220 V or 240 V, in steps of 0.2 N·m (or 2.0 lbf·in). For each torque setting, readjust the voltage control knob of the *Power Supply* so that the armature voltage E_A remains equal to the value recorded in step 22, readjust the field current I_f to the value given in Table 2-1, then record the motor rotation speed n and torque T , as well as the motor armature voltage E_A , armature current I_A , and field current I_f in the *Data Table*.

CAUTION

The armature current I_A will exceed the rated value while performing this manipulation. Therefore, perform this manipulation in less than 5 minutes.

- 24.** When all data has been recorded, stop the *DC Motor/Generator* by setting the voltage control knob to 0% and the main power switch of the *Power Supply* to the O (off) position. (Leave the 24 V ac power source of the *Power Supply* turned on).

In the *Four-Quadrant Dynamometer/Power Supply* window, set the *Torque* parameter to 0.0 N·m (0.0 lbf·in).

In the *Data Table* window, confirm that the data has been stored, save the data table under filename DT212, and print the data table if desired.

The results obtained are presented below.

When the motor torque T is expressed in N·m:

Armature voltage, armature current, field current, rotation speed, and torque (expressed in N·m) of the separately-excited dc motor (DT212).

Motor armature voltage E_A (V)	Motor armature current I_A (A)	Motor field current I_f (A)	Motor rotation speed n (r/min)	Motor torque T (N·m)
117	0.654	0.300	1500	0.33
117	0.960	0.300	1461	0.53
117	1.275	0.300	1424	0.74
117	1.583	0.300	1395	0.93
117	1.891	0.300	1367	1.14
117	2.212	0.301	1333	1.34
117	2.550	0.300	1308	1.53
117	2.895	0.300	1278	1.74
117	3.261	0.300	1246	1.93

When the motor torque T is expressed in lbf·in:

Armature voltage, armature current, field current, rotation speed, and torque (expressed in lbf·in) of the separately-excited dc motor (DT212).

Motor armature voltage E_A (V)	Motor armature current I_A (A)	Motor field current I_f (A)	Motor rotation speed n (r/min)	Motor torque T (lbf·in)
117	0.619	0.300	1500	2.93
117	0.958	0.300	1460	4.94
117	1.285	0.300	1417	6.95
117	1.625	0.300	1378	8.94
117	1.993	0.300	1347	10.9
117	2.363	0.300	1314	12.9
117	2.761	0.300	1283	14.9
117	3.188	0.300	1249	16.9

25. In the Graph window, make the appropriate settings to obtain a graph of the dc motor torque T as a function of the armature current I_A . Name the graph "G212", name the x-axis "Armature current", name the y-axis "Motor torque", and print the graph if desired.

The resulting graphs are shown below.

When the motor torque T is expressed in N·m:

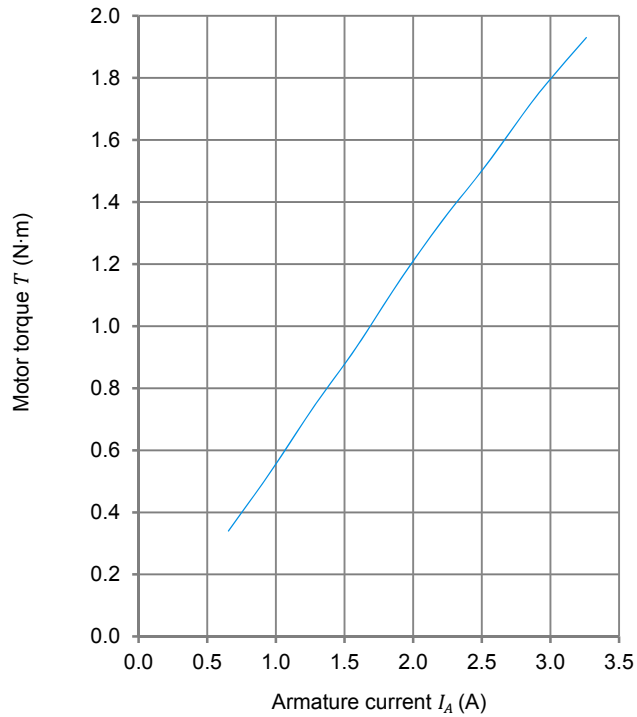

Separately-excited dc motor torque T (expressed in N·m) versus armature current I_A (G212).

When the motor torque T is expressed in lbf·in:

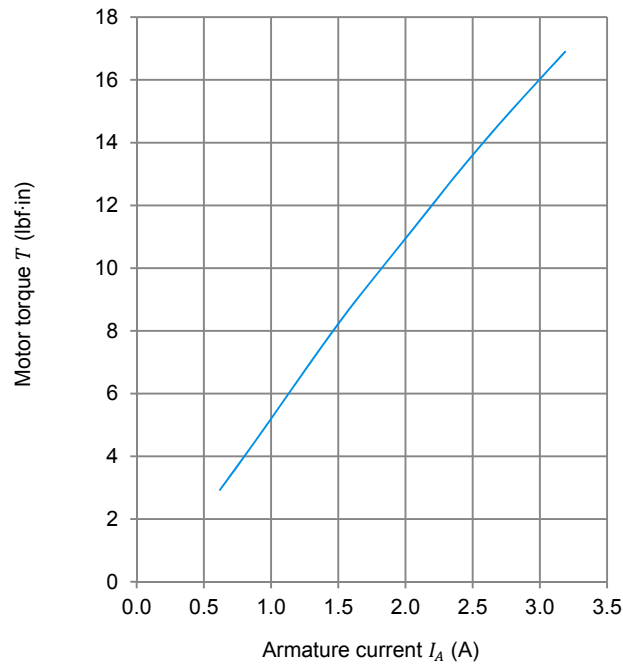

Separately-excited dc motor torque T (expressed in lbf·in) versus armature current I_A (G212).

What kind of relationship exists between the armature current I_A and the dc motor torque T as long as the armature current does not exceed the nominal value?

A linear relationship (see figure)

Does this graph confirm that the separately-excited dc motor is equivalent to a linear current-to-torque converter (when the armature current does not exceed the nominal value), with higher current producing greater torque?

Yes No



The torque-versus-current relationship is no longer linear when the armature current I_A exceeds the nominal value because of a phenomenon called armature reaction. This phenomenon is described in the next unit of this manual.

Yes

26. Use the two end points of the linear portion of the relationship obtained in graph G212 to calculate the slope K_2 . The values of these points are indicated in data table DT212.

$$K_2 = \frac{T_2 - T_1}{I_2 - I_1} = \frac{\quad - \quad}{\quad - \quad} = \frac{\quad}{\quad} \frac{\text{N} \cdot \text{m} (\text{lbf} \cdot \text{in})}{\text{A}}$$

When the motor torque T is expressed in N·m:

$$K_2 = \frac{T_2 - T_1}{I_2 - I_1} = \frac{1.74 \text{ N} \cdot \text{m} - 0.33 \text{ N} \cdot \text{m}}{2.90 \text{ A} - 0.65 \text{ A}} = 0.63 \frac{\text{N} \cdot \text{m}}{\text{A}}$$

When the motor torque T is expressed in lbf·in:

$$K_2 = \frac{T_2 - T_1}{I_2 - I_1} = \frac{14.9 \text{ lbf} \cdot \text{in} - 2.93 \text{ lbf} \cdot \text{in}}{2.76 \text{ A} - 0.62 \text{ A}} = 5.59 \frac{\text{lbf} \cdot \text{in}}{\text{A}}$$

Speed decrease versus armature current

In this section, you will demonstrate that when the armature voltage E_A is set to a fixed value, the speed of the separately-excited dc motor decreases with increasing armature current or torque because of the increasing voltage drop across the armature resistor.

27. Using the values determined previously for the armature resistance R_A (step 11), constant K_1 (step 19), and armature voltage E_A (step 22), calculate the motor rotation speed n for each of the three armature currents I_A given in Table 2-2 for your local ac power network.

$$E_{RA} = I_A \times R_A$$

$$E_{CEMF} = E_A - E_{RA}$$

$$n = E_{CEMF} \times K_1$$

Table 2-2. DC motor armature currents I_A .

Local ac power network		Armature current I_A (A)		
Voltage (V)	Frequency (Hz)			
120	60	1.0	2.0	3.0
220	50	0.5	1.0	1.5
240	50	0.5	1.0	1.5
220	60	0.5	1.0	1.5

When $I_A = \underline{\hspace{2cm}}$ A:

$$E_{RA} = \underline{\hspace{2cm}} \text{ V}$$

$$E_{CEMF} = \underline{\hspace{2cm}} \text{ V}$$

$$n = \underline{\hspace{2cm}} \text{ r/min}$$

When $I_A = 1.0 \text{ A}$:

$$E_{RA} = 7.6 \text{ V}$$

$$E_{CEMF} = 109.4 \text{ V}$$

$$n = 1411 \text{ r/min}$$

When $I_A = \underline{\hspace{2cm}}$ A:

$$E_{RA} = \underline{\hspace{2cm}} \text{ V}$$

$$E_{CEMF} = \underline{\hspace{2cm}} \text{ V}$$

$$n = \underline{\hspace{2cm}} \text{ r/min}$$

When $I_A = 2.0$ A:

$$E_{RA} = 15.2 \text{ V}$$

$$E_{CEMF} = 101.8 \text{ V}$$

$$n = 1313 \text{ r/min}$$

When $I_A = \underline{\hspace{2cm}}$ A:

$$E_{RA} = \underline{\hspace{2cm}} \text{ V}$$

$$E_{CEMF} = \underline{\hspace{2cm}} \text{ V}$$

$$n = \underline{\hspace{2cm}} \text{ r/min}$$

When $I_A = 3.0$ A:

$$E_{RA} = 22.8 \text{ V}$$

$$E_{CEMF} = 94.2 \text{ V}$$

$$n = 1215 \text{ r/min}$$

Based on your results, how should voltage E_{CEMF} and the dc motor speed n vary as the armature current I_A is increased?

The dc motor voltage E_{CEMF} and speed n should decrease when the armature current I_A is increased.

- 28.** In the **Graph** window, make the appropriate settings to obtain a graph of the dc motor speed n as a function of the armature current I_A , using the data recorded previously in data table DT212. Name the graph "G212-1", name the x-axis "Armature current", name the y-axis "Motor speed", and print the graph if desired.

The resulting graph is shown below.

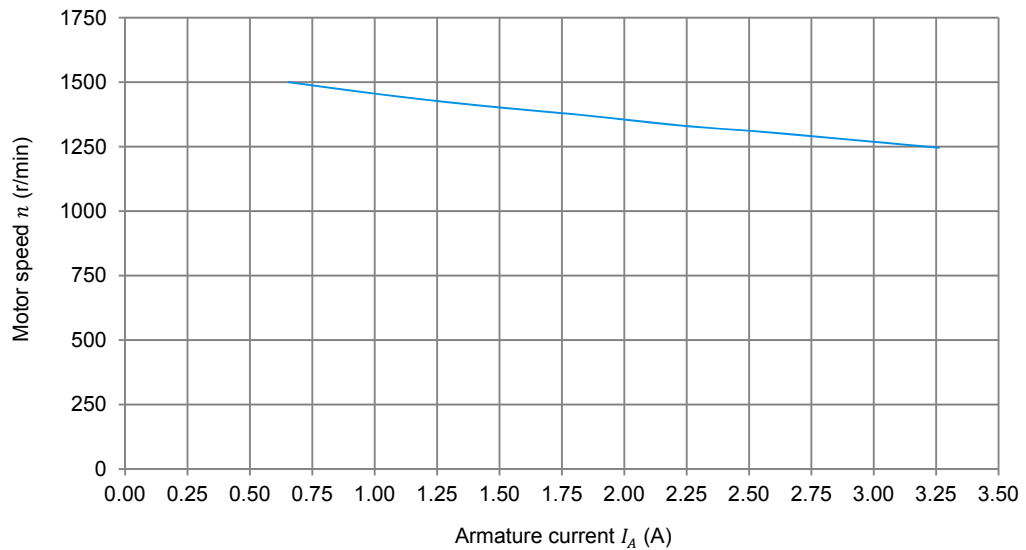

Separately-excited dc motor speed n versus armature current I_A (G212-1).

Does graph G212-1 confirm the prediction you made in the previous step about the variation of the dc motor speed n as a function of the armature current I_A ?

Yes No

Yes (see figure above).

Briefly explain what causes the dc motor speed n to decrease when the armature voltage E_A is fixed and the armature current I_A increases.

The decrease in motor speed n is caused by the increasing voltage drop across the armature resistor as the armature current I_A increases.

29. In the Graph window, make the appropriate settings to obtain a graph of the dc motor speed n as a function of the dc motor torque T using the data recorded previously in data table DT212. Name the graph “G212-2”, name the x-axis “Motor torque”, name the y-axis “Motor speed”, and print the graph. This graph will be used in the next exercise of this unit.

The resulting graphs are shown below.

When the motor torque T is expressed in N·m:

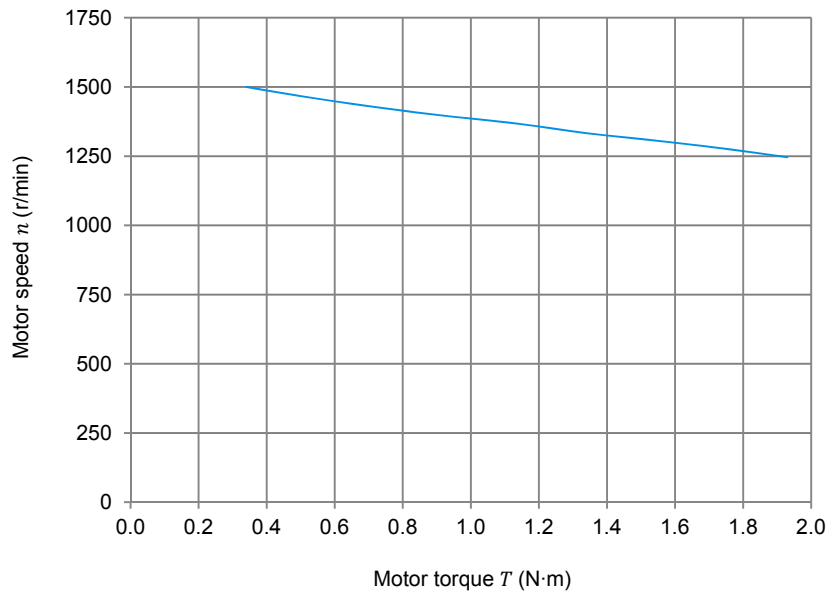

Separately-excited dc motor speed n versus motor torque T (G212-2).

When the motor torque T is expressed in lbf·in:

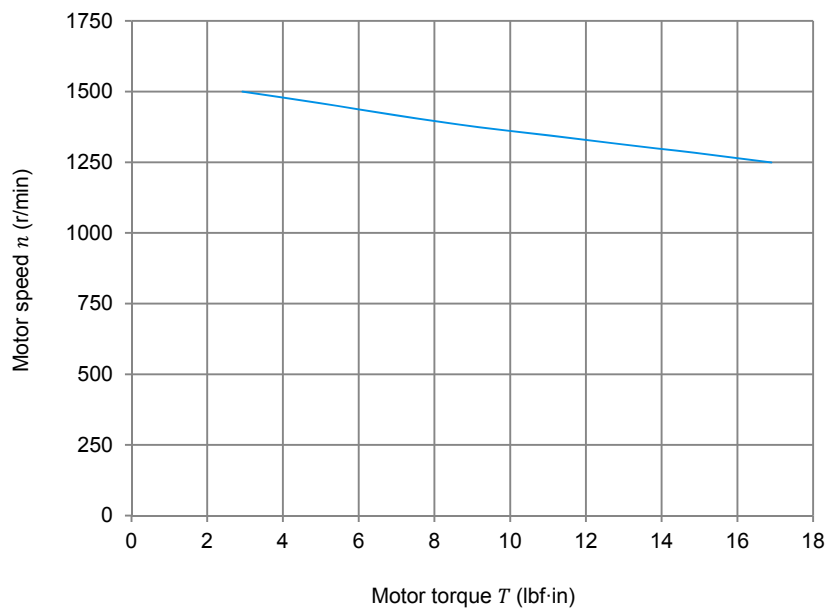

Separately-excited dc motor speed n versus motor torque T (G212-2).



If you want to perform the additional experiments, skip the next step, then return to it when all additional manipulations are finished.

30. On the **Power Supply**, make sure that the main power switch is set to the O (off) position, then turn the 24 V ac power source off. Close the **LVDAC-EMS** software. Turn the **Four-Quadrant Dynamometer/Power Supply** off. Disconnect all leads and return them to their storage location.

Additional experiments (optional)

Motor speed-versus-armature voltage and motor torque-versus-armature current characteristics for reversed armature connections

You can obtain graphs of the dc motor speed n as a function of the armature voltage E_A , and dc motor torque T as a function of the armature current I_A , with reversed armature connections. To do so, make sure that the **Power Supply** is turned off [main power switch set to the O (off) position] and reverse the connections at the variable dc voltage output (voltage source E_S) in Figure 2-16. Make sure that the voltage control knob of the **Power Supply** is set to 0%. Refer to steps 13 to 25 of this exercise to record the necessary data and obtain the graphs. This will allow you to verify that the linear relationships between the motor speed n and armature voltage E_A , and between the motor torque T and armature current I_A , are valid regardless of the polarity of the armature voltage E_A . Recalculating constants K_1 and K_2 will show you that their values are independent of the armature voltage polarity.

Motor speed-versus-armature voltage characteristic for reversed armature connections

Armature voltage, armature current, field current, rotation speed, and torque of the separately-excited dc motor (for reversed armature connections).

Motor armature voltage E_A (V)	Motor armature current I_A (A)	Motor field current I_f (A)	Motor rotation speed n (r/min)	Motor torque T (N·m or lbf·in)
0.037	0.00	0.300	0	0.00 N·m (0.00 lbf·in)
-13.47	-0.444	0.300	-136	-0.19 N·m (-1.68 lbf·in)
-27.63	-0.492	0.300	-326	-0.22 N·m (-1.95 lbf·in)
-40.94	-0.521	0.298	-506	-0.24 N·m (-2.12 lbf·in)
-54.51	-0.542	0.298	-690	-0.26 N·m (-2.30 lbf·in)
-68.3	-0.556	0.297	-877	-0.28 N·m (-2.48 lbf·in)
-82.07	-0.581	0.297	-1061	-0.29 N·m (-2.57 lbf·in)

Motor armature voltage E_A (V)	Motor armature current I_A (A)	Motor field current I_f (A)	Motor rotation speed n (r/min)	Motor torque T (N·m or lbf·in)
-96.33	-0.592	0.297	-1255	-0.30 N·m (-2.66 lbf·in)
-110.1	-0.604	0.297	-1439	-0.32 N·m (-2.83 lbf·in)
-124.9	-0.62	0.297	-1630	-0.33 N·m (-2.92 lbf·in)
-138.4	-0.635	0.297	-1813	-0.35 N·m (-3.09 lbf·in)

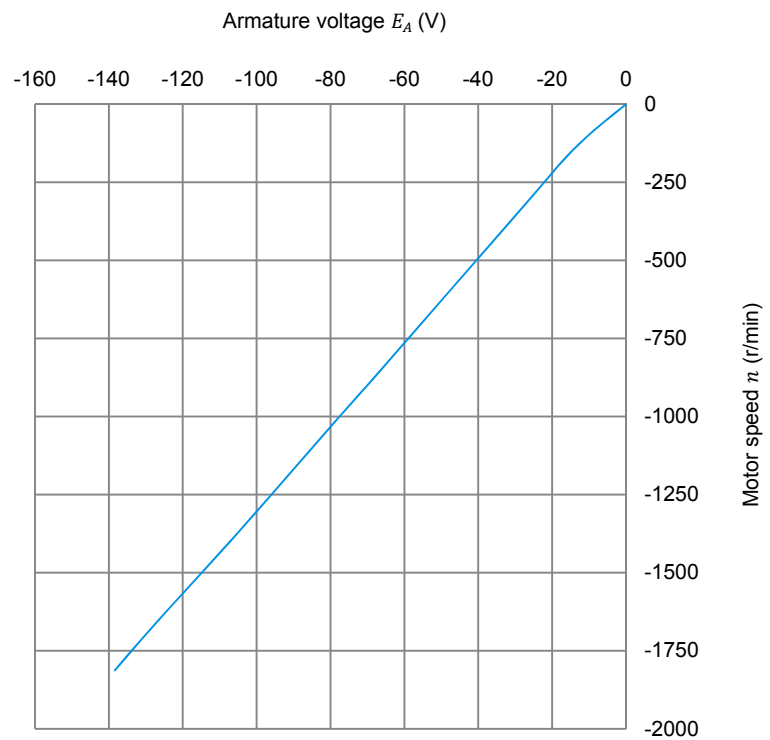

Separately-excited dc motor speed n versus armature voltage E_A (for reversed armature connections).

Motor torque-versus-armature current characteristic for reversed armature connections

When the motor torque T is expressed in N·m:

Armature voltage, armature current, field current, rotation speed, and torque (expressed in N·m) of the separately-excited dc motor (for reversed armature connections).

Motor armature voltage E_A (V)	Motor armature current I_A (A)	Motor field current I_f (A)	Motor rotation speed n (r/min)	Motor torque T (N·m)
-116	-0.570	0.300	-1500	-0.32
-116	-0.860	0.300	-1461	-0.52
-116	-1.166	0.300	-1419	-0.72
-116	-1.463	0.300	-1390	-0.92
-116	-1.770	0.300	-1360	-1.12
-116	-2.104	0.300	-1331	-1.32
-116	-2.429	0.300	-1296	-1.52
-116	-2.785	0.300	-1268	-1.72
-116	-3.163	0.300	-1239	-1.92

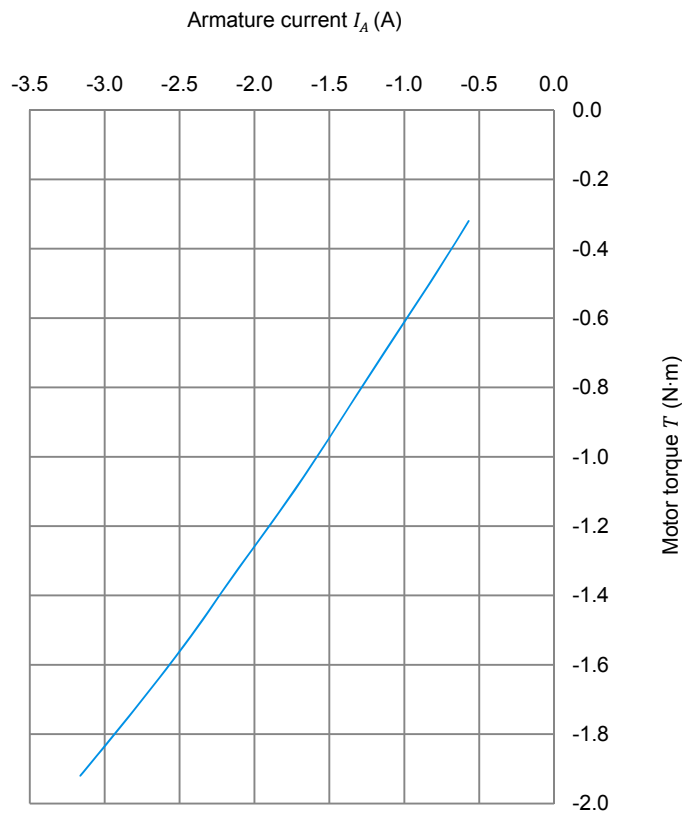

Separately-excited dc motor torque T (expressed in N·m) versus armature current I_A (for reversed armature connections).

When the motor torque T is expressed in lbf-in:

Armature voltage, armature current, field current, rotation speed, and torque (expressed in lbf-in) of the separately-excited dc motor (for reversed armature connections).

Motor armature voltage E_A (V)	Motor armature current I_A (A)	Motor field current I_f (A)	Motor rotation speed n (r/min)	Motor torque T (lbf-in)
-116	-0.564	0.300	-1500	-2.84
-116	-0.884	0.300	-1455	-4.82
-116	-1.226	0.300	-1413	-6.82
-116	-1.561	0.300	-1375	-8.81
-116	-1.933	0.300	-1338	-10.8
-116	-2.302	0.300	-1307	-12.8
-116	-2.675	0.300	-1280	-14.8
-116	-3.088	0.300	-1245	-16.8

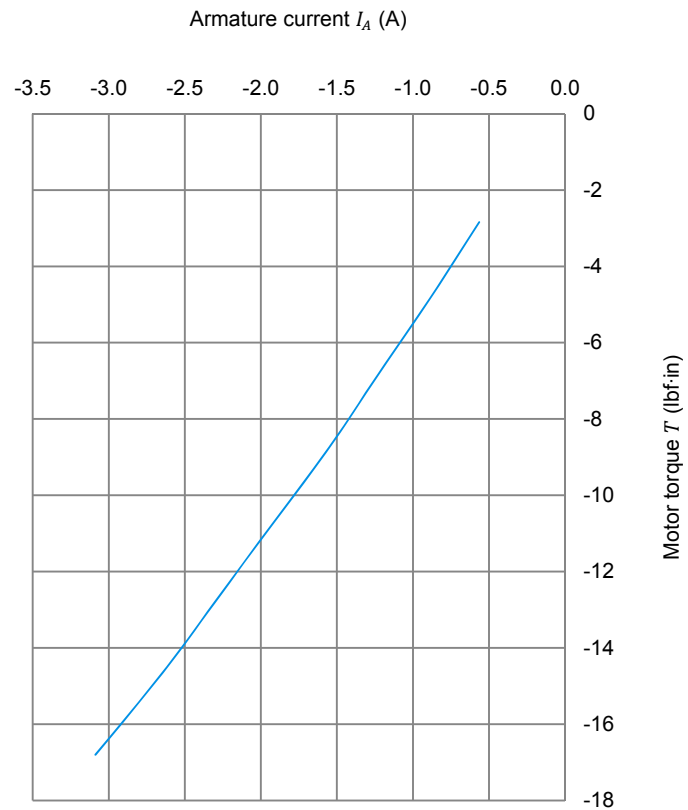

Separately-excited dc motor torque T (expressed in lbf-in) as a function of the armature current I_A (for reversed armature connections).

CONCLUSION

In this exercise, you learned how to measure the armature resistance of a dc motor. You saw that the rotation speed of a separately-excited dc motor is proportional to the armature voltage applied to the motor. You saw that the torque produced by a dc motor is proportional to the armature current. You observed that the dc motor speed decreases with increasing armature current when the armature voltage is fixed. You demonstrated that this speed decrease is caused by the increasing voltage drop across the armature resistor as the armature current increases.

If you performed the additional experiments, you observed that the speed-versus-armature voltage and torque-versus-armature current relationships are not affected by the polarity of the armature voltage. You also observed that the direction of rotation is reversed when the polarity of the armature voltage is reversed.

REVIEW QUESTIONS

1. What kind of relationship exists between the rotation speed and armature voltage of a separately-excited dc motor?

A linear relationship.

2. What kind of relationship exists between the torque and armature current of a separately-excited dc motor as long as the armature current does not exceed the nominal value?

A linear relationship.

3. Connecting a dc power source to the armature of a dc motor that operates without field current and measuring the voltage that produces nominal current flow in the armature allows which parameter of the dc motor to be determined?

The armature resistance.

4. Does the rotation speed of a separately-excited dc motor increase or decrease when the armature current increases?

The rotation speed decreases.

5. The armature resistance R_A and constant K_1 of a dc motor are 0.5Ω and 5 r/min/V , respectively. A voltage of 200 V is applied to this motor. The no-load armature current is 2 A . At full load, the armature current increases to 50 A . What are the no-load and full-load speeds of the motor?

The no-load speed is 995 r/min , while the full-load speed is 875 r/min .

Bibliography

Boylestad, Robert L., *Introductory Circuit Analysis*, 11th Edition, Upper Saddle River: Prentice Hall, 2006, ISBN 978-0131730441.

Wildi, Theodore, *Electrical Machines, Drives, and Power Systems*, 6th Edition, Upper Saddle River: Prentice Hall, 2005, ISBN 978-0131776913.