

Process Control Training Systems 6090

FESTO

LabVolt Series

Datasheet



* The product images shown in this document are for illustration purposes; actual products may vary. Please refer to the Specifications section of each product/item for all details. Festo Didactic reserves the right to change product images and specifications at any time without notice.

Festo Didactic
en 120 V - 60 Hz
11/2024

Table of Contents

General Description	3
Structure of the Process Control Training Systems	3
Topic Coverage	5
Features & Benefits	6
List of Available Training Systems	6
Additional Equipment Required to Perform the Exercises (Purchased separately)	6
Available Training Systems	7
Equipment Description	20
Optional Equipment Description	44

General Description

The Process Control Training Systems form a complete program designed to familiarize students with the fundamentals of instrumentation and process control. It demonstrates the control of pressure, flow, level, temperature, and pH processes. It can also demonstrate advanced process control techniques, such as feed-forward control, second-order control, and cascade control when used with a controller featuring these functions.

A large selection of PID controllers and programmable logic controllers is available to control the processes. An Instrumentation Workstation, Model 6305, is required to keep the controller attached to the side of the station.

Structure of the Process Control Training Systems

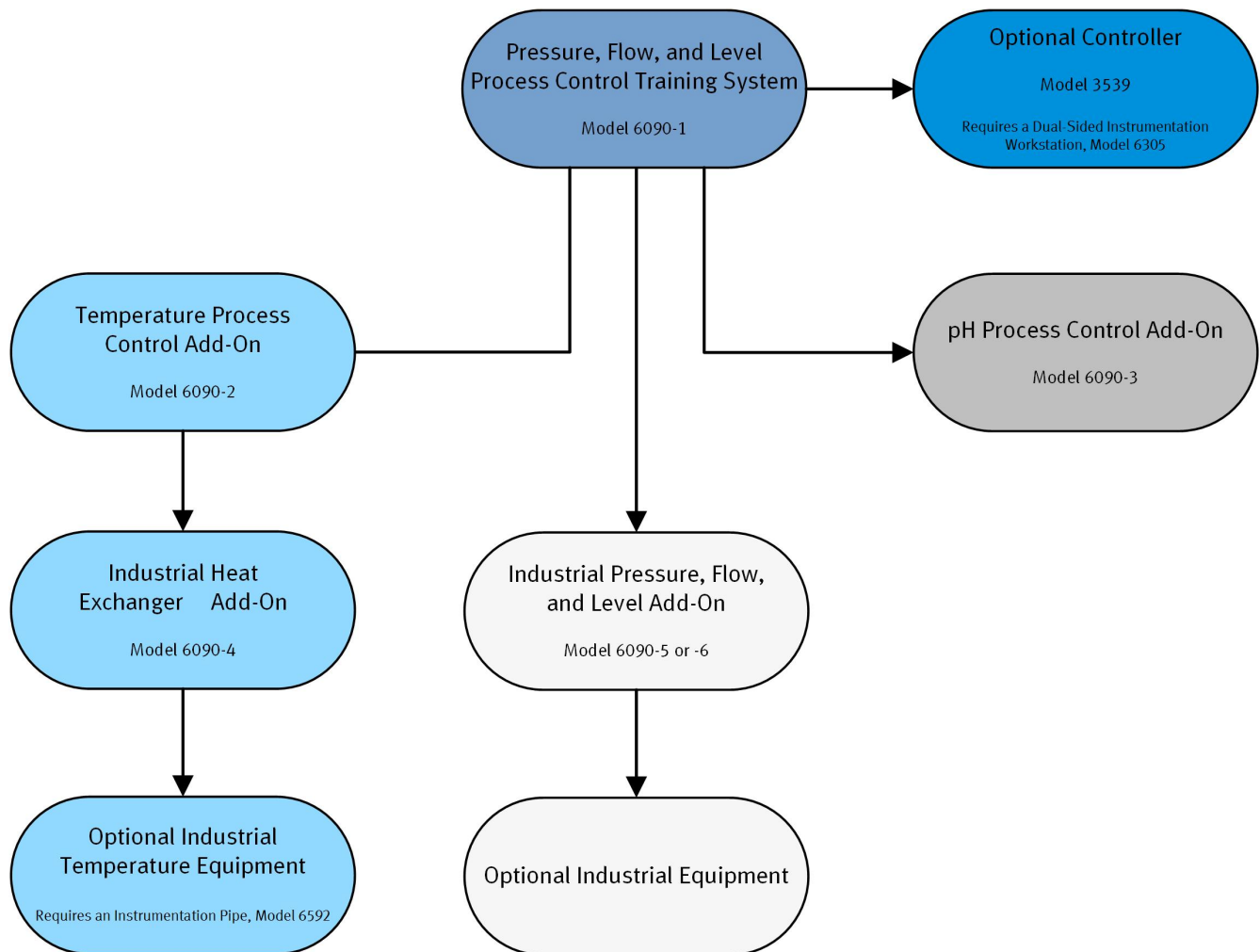

Structure of the Process Control Training System

		System Part Number		
		HART	FOUNDATION Fieldbus	
System Name				
Main system	Pressure, Flow, and Level Process Control Training System	6090-1		
Add-on	Temperature Process Control Add-On (requires Model 6090-1)	6090-2		
Industrial add-on	Industrial Heat Exchanger Add-On (requires Model 6090-2)	6090-4		
Add-on	pH Process Control Add-On (requires Model 6090-1)	6090-3		
Industrial add-on	Industrial Pressure, Flow, and Level Add-On (requires Model 6090-1)	6090-5	6090-6	
Entry-level solutions	Pressure, Flow, and Level Process Control Training System (Entry-Level Solution)	6090-8		
	Pressure, Flow, Level, and Temperature Process Control Training System (Entry-Level Solution)	6090-9		
Optional controllers ²	PID	Foxboro 762 Controller	3539-0 ²	-
		Honeywell Controller	3539-1 ²	-
	PLC	ControlLogix PLC (HART)	3539-5 ²	3539-5 ^{1,2}
		MicroLogix PLC	3539-7 ²	-
		CompactLogix PLC	3539-8 ²	3539-8 ^{1,2}
		FOUNDATION Fieldbus PLC Add-On	-	3539-9 ^{1,2}
		S7-1500 PLC Bundle HART – Educational	3539-P ²	-
		S7-1500 PLC Bundle – Educational	3539-S ²	-

		Model Part Number	
		HART	FOUNDATION Fieldbus
Model Name			
Configurators	HART Software Configurator	46982-0	-
	FOUNDATION Fieldbus Software Configurator	-	46982-A
	HART and FOUNDATION Fieldbus Software Configurator	46982-B	

Transmitters	Pressure	Digital Pressure Gauge (High Range)	6553-A	
		Analog Pressure Gauge (Medium Range)	6553-C	
		Digital Pressure Gauge (Medium Range)	6553-D	
		Pressure Switch with Analog Output	46926-0	
		Pressure Transmitter	46928-0	46928-A
	Flow	Electromagnetic Flow Transmitter	46922-1	46922-B
		Vortex Flow Transmitter	46923-0	46923-A
		Coriolis Flow Transmitter	46924-0	46924-A
	Temperature	Thermocouple J-Type Probe	46916-0	
		Platinum RTD 100 Probe	46917-0	
Temperature Transmitter		46940-0	46940-A	
pH	pH Transmitter	46945-0	46945-A	

	Model Name	Model Part Number	
		HART	FOUNDATION Fieldbus
Calibration	Calibration Kit	46980-0	
	Calibration Kit with Pressure Modules	46980-A	
	Calibration Kit (HART)	46981-0	-
	Calibration Kit (HART and FOUNDATION Fieldbus)	46980-1	
SCADA / DCS	Wonderware InTouch	3675-0	-
	FactoryTalk View ME	46968-0	46968-0
	WinCC Advanced Development Software – Educational	46984-0	-
Additional Optional Accessories	Touch-Screen Computer Mount	3451-A ²	
	Table	3452-0	
	Touch Screen Graphic Terminal - 14.5 cm (5.7 in) (requires a PLC)	5922-B ²	
	Signal Tower	5924-0	
	Indicator Lights / Push-Button Station	5925-A ²	
	Emergency Switch Station	5926-A ²	
	Fuzzy Logic Software (requires RSLogix 5000)	5938-0	
	Dual-Sided Instrumentation Workstation	6305-0	
	24 V DC Power Supply	6360-A	
	Unmanaged Switch (Allen-Bradley)	20486-0 ²	
	Acoustic Alarm	39303-0 ³	
	Touch-Screen Computer	46299-0	
	Touch-Screen Computer – Large	46299-A	
	Touch Screen Graphic Terminal (Allen-Bradley) - 26.4 cm (10.4 in)	46973-0 ²	
	Industrial PC HMI (Siemens)	46973-A ²	
	Storage Station	46801-D	
	Color Paperless Recorder	46972-0 ²	
	Water Analyzer	46989-0	
Custom Computer	46999-0		
Unmanaged Switch (Siemens)	52390-0 ²		

¹ : The ControlLogix and CompactLogix PLCs can be used with the FOUNDATION Fieldbus communication protocol if a FOUNDATION Fieldbus PLC Add-On, Model 3539-9 or -E) is used.

² : Requires a Dual-Sided Instrumentation Workstation, Model 6305-0.

³ : Requires a Tower Signal, Model 5924-0.

Topic Coverage

- Pressure, Flow and Level Processes
- PID Controller and Process Control
- Temperature Processes and Measurement
- pH Control and Measurement
- Process Dynamics
- Proportional Plus Integral/Derivative Control Mode
- Estimated total program duration: 110 hours

Features & Benefits

- Equipment
 - Many work surface, bench, and panel options
 - Stainless-steel drip tray
 - Cost-effective solution when compared to industrial training systems
 - Bench offers lockable storage
 - Wide range of add-ons and optional components to expand learning
 - Moveable components build a foundation of knowledge one device at a time, making it easier to teach circuit assembly
 - Create circuits to mimic industry-specific process control applications
 - Fault switches on most of the industrial components enable real-world troubleshooting
 - HART or FOUNDATION Fieldbus communication protocols
 - Environmentally friendly temperature training system (no cooling water required)
- Curriculum
 - Process control simulation software available
 - Curriculum available in job-sheet format in standard student activity manuals or in PDF format on CD-ROM as a site license
 - Innovative approach that also allows interconnection with other products, such as pneumatics applications, PLCs, etc.

List of Available Training Systems

Qty	Description	Model number
1	Pressure, Flow, and Level Process Control Training System _____	588661 (6090-10)
1	Temperature Process Control Add-On _____	588667 (6090-20)
1	pH Process Control Add-On _____	588674 (6090-30)
1	Industrial Heat Exchanger Add-On _____	588678 (6090-40)
1	Industrial Pressure, Flow, and Level Add-On - HART _____	588680 (6090-50)
1	Pressure, Flow, and Level Process Control Training System (Entry-Level Solution) _____	589633 (6090-80)
1	Pressure, Flow, Level, and Temperature Process Control Training System (Entry-Level Solution) _____ (6090-90)	589638
1	Pressure, Flow, and Level Process Control Training System (with Bench and Panels) _____	588655 (6090-B0)

Additional Equipment Required to Perform the Exercises (Purchased separately)

Qty	Description	Model number
1	Personal Computer _____	579785 (8990-00) ¹
1	Rust Inhibitor Solution _____	777198 (38096-00)
1	Antibacterial Solution _____	8060736 (38097-00)
1	Touch-Screen Computer – Large _____	589677 (46299-A0) ²

¹ Refer to the Computer Requirements in the System Specifications section of this datasheet if the computer is to be provided by the end-user.

² Refer to the Computer Requirements in the System Specifications section of this datasheet if the computer is to be provided by the end-user.

Available Training Systems

Pressure, Flow, and Level Process Control Training System 588661 (6090-10)

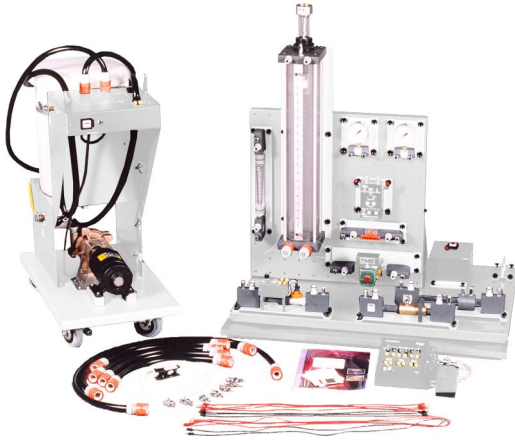

The Pressure, Flow, and Level Process Control Training System is a cost-effective alternative to systems using industrial grade components. It meets the training requirements of instructors wishing to teach process control fundamentals in any vocational school or college.

The training system demonstrates PID (proportional, integral, derivative) control of flow, pressure, and level processes. The workstation can be configured to accommodate a wide variety of space and teaching needs with different benches, work surfaces, and optional equipment. The equipment has several switches to enable instructors to insert faults in the system for real-world troubleshooting.

The training system includes a variable-speed pump, a tank, a column, two-way valves, pressure gauges, flexible hoses, a venturi tube, an orifice plate, a rotameter, a paddle wheel flow transmitter, and a differential pressure transmitter. A work surface consisting of a solid perforated plate hinged to a drip tray provides a large area (that can be laid flat or tilted to a 45° angle) on which components can be mounted. Additional work area can be added using the provided expanding work surface. The drip tray is made of stainless steel.

Mounting and removing components is especially easy using quick-lock fixations and knobs that enable components to be locked in the perforations of the work surface. The components can be interconnected by means of flexible hoses equipped with garden-type fittings that permit easy and fast component connections without the use of tools. The hose fittings contain check valves to prevent water from running out of the hoses when they are disconnected.

Although the equipment is designed to operate atop a regular work table, an optional bench is available to provide mobility and storage space. Mounted on four heavy-duty, swiveling, lockable casters, the bench provides a storage area for components. Optional dressing panels and lockable doors are also available to fully enclose and lock the bench.

The training system processes can be controlled by a computer-based PID Controller through the use of a personal computer, the included Process Control and Simulation Software (LVProSim), and the I/O Interface, Model 9065. The trainer processes can also be controlled using any conventional PID controller compatible with standard 4-20 mA signals.

Cascade and second-order process control can also be studied on the basic trainer by having the students from two workstations work together at a single workstation, or by adding the following components to the basic trainer: a Pressure Transmitter, a Column, a second I/O interface, or a PID Controller.

The Process Control Training System can also be complemented with equipment packages designed to recreate current industrial practices. These add-ons (6090-4, 6090-5, and 6090-6) improve and diversify the possibilities offered by the system.

List of Equipment

Qty	Description	Model number
1	Pressure, Flow, and Level Processes _____	8089764 (80897-64)
1	Pressure, Flow, and Level Processes (Instructor) _____	8089768 (80897-68)
1	Work Surface (Stainless Steel) _____	587925 (6301-A0)
1	Expanding Work Surface (Large) _____	763446 (6302-00)
1	DC Power Supply _____	587962 (6360-A0)
1	Multimeter _____	582365 (6394-A0)
1	Pumping Unit _____	595991 (6510-20)
1	Column _____	588211 (6511-00)
2	Hand-Operated Two-Way Valve _____	582368 (6520-00)
1	Solenoid-Operated Two-Way Valve _____	588214 (6521-00)
1	Pressure Transmitter _____	588216 (6540-00)
1	Paddle Wheel Flow Transmitter _____	588222 (6542-00)
1	Rotameter _____	582373 (6550-00)
1	Venturi Tube _____	588232 (6551-00)
1	Orifice Plate _____	588233 (6552-00)
2	Pressure Gauge: Analog – Low Range – 0-100 kPa (0-15 psig) _____	582374 (6553-00)
1	Float Switch _____	588242 (6570-00)
1	Hose Set and Accessory Kit _____	588243 (6590-00)
1	I/O Interface with LVProSim _____	763509 (9065-B0)

List of Manuals

Description	Manual number
Pressure, Flow, and Level Processes (Workbook) _____	8089764 (80897-64)
Pressure, Flow, and Level Processes (Workbook (Instructor)) _____	8089768 (80897-68)

Table of Contents of the Manual(s)

Pressure, Flow, and Level Processes (Workbook) (8089764 (80897-64))

- 1-1 Familiarization with the Training System
- 2-1 Pressure Measurement
- 2-2 Pressure Losses
- 2-3 Centrifugal Pumps
- 2-4 Centrifugal Pumps in Series and in Parallel (Optional Exercise)
- 3-1 Rotameters and Paddle Wheel Flowmeters
- 3-2 Orifice Plates
- 3-3 Venturi Tubes
- 3-4 Pitot Tubes and Industrial DP Transmitters (Optional Exercise)
- 4-1 Float Switches
- 4-2 Differential Pressure Level Meters
- 4-3 Zero Suppression and Zero Elevation
- 4-4 Wet Reference Legs (Optional Exercise)
- 4-5 Bubblers (Optional Exercise)
- 4-6 Ultrasonic Level Transmitters (Optional Exercise)
- 5-1 Determining the Dynamic Characteristics of a Process
- 6-1 Pressure Process Control

- 6-2 Flow Process Control
- 6-3 Level Process Control
- 6-4 Cascade Process Control (Optional Exercise)
- 6-5 Second-Order Process Control (Optional Exercise)

System Specifications

Parameter	Value
Power Requirements	
Current	5 A
Physical Characteristics	
Intended Location	On the floor (stands on casters)
Dimensions (H x W x D)	1830 x 1220 x 700 mm (72 x 48 x 28 in)
Net Weight	TBE

Temperature Process Control Add-On 588667 (6090-20)



The Temperature Process Control Add-On provides additional components to the Pressure, Flow, and Level Process Control Training System, Model 6090-1, in order to demonstrate PID control of temperature. It includes a heating unit, a cooling unit, a thermocouple temperature transmitter and a RTD temperature transmitter.

List of Equipment

Qty	Description	Model number
1	Temperature Process and Heat Exchanger _____	588944 (88461-00)
1	Temperature Process and Heat Exchanger (Instructor) _____	588945 (88461-10)
1	Heating Unit _____	582369 (6530-00)
1	Radiator _____	582372 (6531-00)
1	Thermocouple Temperature Transmitter _____	588219 (6541-00)
1	RTD Temperature Transmitter _____	588225 (6543-00)

List of Manuals

Description	Manual number
Temperature Process and Heat Exchanger (Workbook) _____	588944 (88461-00)
Temperature Process and Heat Exchanger (Workbook (Instructor)) _____	588945 (88461-10)

Table of Contents of the Manual(s)

Temperature Process and Heat Exchanger (Workbook) (588944 (88461-00))

- 1-1 Familiarization with the Training System

- 2-1 Resistance Temperature Detectors (RTDs)
- 2-2 Thermocouples
- 2-3 Thermal Energy Transfer in Temperature Processes
- 2-4 Heat Exchangers (Optional Exercise)
- 3-1 Characterization of a Temperature Process in the Heating Mode
- 3-2 Characterization of a Temperature Process in the Cooling Mode
- 4-1 PI Control of a Temperature Process in the Heating Mode
- 4-2 PI Control of a Temperature Process in the Cooling Mode

System Specifications

Parameter	Value
Power Requirements	
Current	10 A
Physical Characteristics	
Intended Location	Installed on the Pressure, Flow, and Level Process Control Training System, Model 6090-1. Does not require any additional space.
Net Weight	TBE

pH Process Control Add-On 588674 (6090-30)

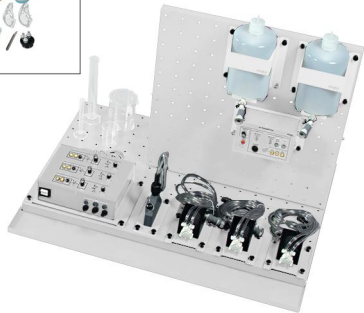

The pH Process Control Add-On provides additional components to the Pressure, Flow, and Level Process Control, Model 6090-1, in order to demonstrate PID control of pH processes. It includes a metering pump, two chemical tanks, a pH transmitter, a metering pump drive, a set point device, pH process control accessories, and pH process control consumables.

List of Equipment

Qty	Description	Model number
1	pH Process Control _____	584825 (38921-00)
1	pH Process Control (Instructor) _____	584827 (38921-10)
3	Metering Pump _____	588212 (6512-00)
2	Chemical Tank _____	588213 (6513-00)
1	pH Transmitter _____	588228 (6544-00)
1	Metering Pump Drive _____	588238 (6560-00)
1	Set Point Device _____	588241 (6561-00)
1	pH Process Control Accessories _____	588244 (6591-00)
1	pH Process Control Consumables for 6090 _____	588246 (6599-00)

List of Manuals

Description	Manual number
pH Process Control (Workbook) _____	584825 (38921-00)

Description**Manual
number**

pH Process Control (Workbook (Instructor)) _____ 584827 (38921-10)

Table of Contents of the Manual(s)**pH Process Control (Workbook) (584825 (38921-00))**

- 1-1 Familiarization with the Training System
- 2-1 pH Electrodes
- 2-2 Titration of a Strong Acid
- 2-3 Titration of Weak Acids
- 2-4 Titration of a Buffer Solution
- 3-1 Characterization of a Strong-Acid pH Process
- 3-2 Characterization of a Weak-Acid pH Process
- 4-1 PID and On-Off Control of a Batch pH Process
- 4-2 PID Control of a Continuous pH Process

System Specifications

Parameter	Value
Power Requirements	
Current	6 A
Physical Characteristics	
Intended Location	Installed on the Pressure, Flow, and Level Process Control Training System, Model 6090-1. Does not require any additional space.
Net Weight	TBE

**Industrial Heat Exchanger Add-On
588678 (6090-40)**

The Industrial Heat Exchanger Add-On adds a Heat Exchanger as well as an additional pump to the Pressure, Flow, and Level Process Control Training System, Model 6090-1, to study the exchange of heat between two flows of water at different temperatures. For operation, the Industrial Heat Exchanger Add-On also requires the Temperature Process Control Add-On, Model 6090-2, to be installed on the Pressure, Flow, and Level Process Control Training System.

List of Equipment

Qty	Description	Model number
1	Pumping Unit _____	595991 (6510-20)
1	Heat Exchanger _____	588215 (6532-00)

Qty	Description	Model number
1	Rotameter _____	582373 (6550-00)

Additional Equipment Required to Perform the Exercises (Purchased separately)

Qty	Description	Model number
1	Instrumentation Pipe _____	588245 (6592-00) ³

System Specifications

Parameter	Value
Power Requirements	
Current	3 A
Physical Characteristics	
Intended Location	Installed on the Pressure, Flow, and Level Process Control Training System, Model 6090-1. Does not require any additional space.
Net Weight	TBE

Industrial Pressure, Flow, and Level Add-On - HART 588680 (6090-50)

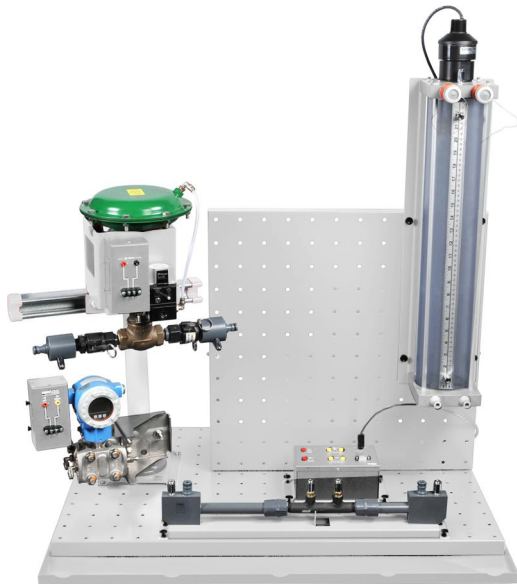

The Industrial Pressure, Flow, and Level Add-On - HART is an add-on to the Pressure, Flow, and Level Process Control Training System that comprises an ultrasonic level transmitter, a pitot tube, and a HART differential-pressure transmitter installed on an instrumentation pipe. The level transmitter allows students to continuously monitor the level in the column while the pitot tube and the differential-pressure transmitter measure the flow rate with accuracy. A pneumatic control valve completes this add-on and allows students to exert control over different processes. The two transmitters use a 4-20 mA signal as their output. This allows the use of either a programmable logic controller or a PID controller on the training system.

The Industrial Pressure, Flow, and Level Add-On - HART requires a reliable source of compressed air from either a central air supply or a portable unit which can deliver air at a minimal flow rate of 28 L/min (1 SCFM) with a pressure of 207 kPa (30 PSI). The Air Compressor, Model 6410-C, is a portable unit well suited

to the system.

³ Included with the Industrial Pressure Flow, and Level Add-Ons.

Many industrial accessories that can be installed on a workstation are available. The industrial accessories are mainly meant to demonstrate the principles of operation of industrial devices to students, rather than to allow precise control of the Pressure, Flow, and Level Process Control Training System.

List of Equipment

Qty	Description	Model number
1	Conditioning Unit (Single Port) _____	588111 (6411-A0)
1	Ultrasonic Level Transmitter _____	588231 (6545-00)
1	Pitot Tube _____	588237 (6554-00)
1	Instrumentation Pipe _____	588245 (6592-00)
1	Differential-Pressure Transmitter (HART, Medium Range) _____	588335 (46929-00)
1	Pneumatic Control Valve _____	582424 (46950-B0)

Manual

Description	Manual number
Control Valves (User Guide) _____	585145 (86001-E0)

Table of Contents of the Manual(s)

Control Valves (User Guide) (585145 (86001-E0))

- 1 Basic Control Valve Theory
- 2 Basic Control Valve (46950-B)
- 3 Pneumatic Control Valve with a Positioner (46950-A)
- 4 Control Valve with DVC2000 (46950-0)
- 5 Control Valve with DVC6000 – HART/FF (46950-E/-D)
- 6 Control Valve with DVC6200 – HART/FF (46950-E/-D)
- 7 Electric Control Valve (46950-C)

Additional Equipment Required to Perform the Exercises (Purchased separately)

Qty	Description	Model number
1	Compressor for Meclab _____	556275 (5562-75) ⁴

Software

Qty	Description	Model number
1	FactoryTalk View ME Studio (Educational) _____	588384 (46968-00) ⁵
1	FactoryTalk View ME Station (Educational) _____	588397 (46968-20) ⁶
1	FactoryTalk View ME Studio (Commercial) _____	588385 (46968-A0) ⁷
1	FactoryTalk View ME Station (Commercial) _____	588390 (46968-C0) ⁸

⁴ This compressor can supply up to 2 stations.

⁵ Add-on to an optional Rockwell PLC allowing to program your own HMI (unguided, but the system's sample file is provided).

⁶ Add-on to an optional Rockwell PLC allowing to program your own HMI (unguided, but the system's sample file is provided). Can replace the touch panel HMI.

⁷ Add-on to an optional Rockwell PLC allowing to program your own HMI (unguided, but the system's sample file is provided).

⁸ Add-on to an optional Rockwell PLC allowing to program your own HMI (unguided, but the system's sample file is provided). Can replace the touch panel HMI.

Qty	Description	Model number
1	Step 7 professional and WinCC Advanced, 6 users (perpetual) + 20 Students (1 year), Educational (81646-50) ⁹	8164650
1	Step 7 professional and WinCC Advanced, 20 Students (1 year), Educational	8164652 (81646-52) ¹⁰

System Specifications

Parameter	Value
Power Requirements	
Current	N/A
Physical Characteristics	
Intended Location	Installed on the Pressure, Flow, and Level Process Control Training System, Model 6090-1. Does not require any additional space.
Net Weight	TBE

Pressure, Flow, and Level Process Control Training System (Entry-Level Solution) 589633 (6090-80)

The Pressure, Flow, and Level Process Control Training System is a cost-effective alternative to systems using industrial grade components. It meets the training requirements of instructors wishing to teach process control fundamentals in any vocational school or college.

The training system demonstrates PID (proportional, integral, derivative) control of flow, pressure, and level processes. The workstation can be configured to accommodate a wide variety of space and teaching needs with different benches, work surfaces, and optional equipment. The equipment has several switches to enable instructors to insert faults in the system for real-world troubleshooting.

The Entry-Level Solution permits to perform all basic experiments but not all the ones as a 6090-1 would do. It would require additional models to perform same experiments as this system.

The training system includes a variable-speed pump, a tank, a column, two-way valves, pressure gauges, flexible hoses, a venturi tube, an orifice plate, a rotameter, a paddle wheel flow transmitter, and a differential pressure transmitter. A work surface consisting of a solid perforated plate hinged to a drip tray provides a large area (that can be laid flat or tilted to a 45° angle) on which components can be mounted. Additional work area can be added using the provided expanding work surface. The drip tray is made of stainless steel.

Mounting and removing components is especially easy using quick-lock fixations and knobs that enable components to be locked in the perforations of the work surface. The components can be interconnected by means of flexible hoses equipped with garden-type fittings that permit easy and fast component connections without the use of tools. The hose fittings contain check valves to prevent water from running out of the hoses when they are disconnected.

Although the equipment is designed to operate atop a regular work table, an optional bench is available to provide mobility and storage space. Mounted on four heavy-duty, swiveling, lockable casters, the bench provides a storage area for components. Optional dressing panels and lockable doors are also available to fully enclose and lock the bench.

The training system processes can be controlled by a computer-based PID Controller through the use of a personal computer, the included Process Control and Simulation Software (LVProSim), and the I/O Interface, Model 9065. The trainer processes can also be controlled using any conventional PID controller compatible with standard 4-20 mA signals.

⁹ Add-on to an optional Siemens PLC. Can replace the Industrial PC HMI (Siemens).

¹⁰ Add-on to an optional Siemens PLC. Can replace the the Industrial PC HMI (Siemens).

List of Equipment

Qty	Description	Model number
1	Pressure, Flow, and Level Processes _____	8089764 (80897-64)
1	Pressure, Flow, and Level Processes (Instructor) _____	8089768 (80897-68)
1	Work Surface (Stainless Steel) _____	587925 (6301-A0)
1	Expanding Work Surface (Large) _____	763446 (6302-00)
1	DC Power Supply _____	587962 (6360-A0)
1	Multimeter _____	582365 (6394-A0)
1	Pumping Unit _____	595991 (6510-20)
1	Column _____	588211 (6511-00)
1	Hand-Operated Two-Way Valve _____	582368 (6520-00)
1	Pressure Transmitter _____	588216 (6540-00)
1	Rotameter _____	582373 (6550-00)
1	Venturi Tube _____	588232 (6551-00)
2	Pressure Gauge: Analog – Low Range – 0-100 kPa (0-15 psig) _____	582374 (6553-00)
1	Hose Set and Accessory Kit _____	588243 (6590-00)
1	I/O Interface with LVProSim _____	763509 (9065-B0)

List of Manuals

Description	Manual number
Pressure, Flow, and Level Processes (Workbook) _____	8089764 (80897-64)
Pressure, Flow, and Level Processes (Workbook (Instructor)) _____	8089768 (80897-68)

Table of Contents of the Manual(s)

Pressure, Flow, and Level Processes (Workbook) (8089764 (80897-64))

- 1-1 Familiarization with the Training System
- 2-1 Pressure Measurement
- 2-2 Pressure Losses
- 2-3 Centrifugal Pumps
- 2-4 Centrifugal Pumps in Series and in Parallel (Optional Exercise)
- 3-1 Rotameters and Paddle Wheel Flowmeters
- 3-2 Orifice Plates
- 3-3 Venturi Tubes
- 3-4 Pitot Tubes and Industrial DP Transmitters (Optional Exercise)
- 4-1 Float Switches
- 4-2 Differential Pressure Level Meters
- 4-3 Zero Suppression and Zero Elevation
- 4-4 Wet Reference Legs (Optional Exercise)
- 4-5 Bubblers (Optional Exercise)
- 4-6 Ultrasonic Level Transmitters (Optional Exercise)
- 5-1 Determining the Dynamic Characteristics of a Process
- 6-1 Pressure Process Control
- 6-2 Flow Process Control
- 6-3 Level Process Control
- 6-4 Cascade Process Control (Optional Exercise)
- 6-5 Second-Order Process Control (Optional Exercise)

Pressure, Flow, Level, and Temperature Process Control Training System (Entry-Level Solution) 589638 (6090-90)

The Pressure, Flow, Level, and Temperature Process Control Training System is a cost-effective alternative to systems using industrial grade components. It meets the training requirements of instructors wishing to teach process control fundamentals in any vocational school or college.

The training system demonstrates PID (proportional, integral, derivative) control of flow, pressure, and level processes. The workstation can be configured to accommodate a wide variety of space and teaching needs with different benches, work surfaces, and optional equipment. The equipment has several switches to enable instructors to insert faults in the system for real-world troubleshooting.

The Temperature Process Control demonstrate PID control of temperature. It includes a heating unit, a cooling unit and a RTD temperature transmitter.

The Entry-Level Solution permits to perform all basic experiments but not all the ones as a 6090-1 and 6090-2 would do. It would require additional models to perform same experiments as these systems.

The training system includes a variable-speed pump, a tank, a column, two-way valves, pressure gauges, flexible hoses, a venturi tube, an orifice plate, a rotameter, a paddle wheel flow transmitter, and a differential pressure transmitter. A work surface consisting of a solid perforated plate hinged to a drip tray provides a large area (that can be laid flat or tilted to a 45° angle) on which components can be mounted. Additional work area can be added using the provided expanding work surface. The drip tray is made of stainless steel.

Mounting and removing components is especially easy using quick-lock fixations and knobs that enable components to be locked in the perforations of the work surface. The components can be interconnected by means of flexible hoses equipped with garden-type fittings that permit easy and fast component connections without the use of tools. The hose fittings contain check valves to prevent water from running out of the hoses when they are disconnected.

Although the equipment is designed to operate atop a regular work table, an optional bench is available to provide mobility and storage space. Mounted on four heavy-duty, swiveling, lockable casters, the bench provides a storage area for components. Optional dressing panels and lockable doors are also available to fully enclose and lock the bench.

The training system processes can be controlled by a computer-based PID Controller through the use of a personal computer, the included Process Control and Simulation Software (LVProSim), and the I/O Interface, Model 9065. The trainer processes can also be controlled using any conventional PID controller compatible with standard 4-20 mA signals.

List of Equipment

Qty	Description	Model number
1	Pressure, Flow, and Level Processes _____	8089764 (80897-64)
1	Pressure, Flow, and Level Processes (Instructor) _____	8089768 (80897-68)
1	Temperature Process and Heat Exchanger _____	588944 (88461-00)
1	Temperature Process and Heat Exchanger (Instructor) _____	588945 (88461-10)
1	Work Surface (Stainless Steel) _____	587925 (6301-A0)
1	Expanding Work Surface (Large) _____	763446 (6302-00)
1	DC Power Supply _____	587962 (6360-A0)
1	Multimeter _____	582365 (6394-A0)
1	Pumping Unit _____	595991 (6510-20)
1	Column _____	588211 (6511-00)

Qty	Description	Model number
1	Hand-Operated Two-Way Valve _____	582368 (6520-00)
1	Heating Unit _____	582369 (6530-00)
1	Radiator _____	582372 (6531-00)
1	Pressure Transmitter _____	588216 (6540-00)
1	RTD Temperature Transmitter _____	588225 (6543-00)
1	Rotameter _____	582373 (6550-00)
1	Venturi Tube _____	588232 (6551-00)
2	Pressure Gauge: Analog – Low Range – 0-100 kPa (0-15 psig) _____	582374 (6553-00)
1	Hose Set and Accessory Kit _____	588243 (6590-00)
1	I/O Interface with LVProSim _____	763509 (9065-B0)

List of Manuals

Description	Manual number
Temperature Process and Heat Exchanger (Workbook) _____	588944 (88461-00)
Temperature Process and Heat Exchanger (Workbook (Instructor)) _____	588945 (88461-10)
Pressure, Flow, and Level Processes (Workbook) _____	8089764 (80897-64)
Pressure, Flow, and Level Processes (Workbook (Instructor)) _____	8089768 (80897-68)

Table of Contents of the Manual(s)

Temperature Process and Heat Exchanger (Workbook) (588944 (88461-00))

- 1-1 Familiarization with the Training System
- 2-1 Resistance Temperature Detectors (RTDs)
- 2-2 Thermocouples
- 2-3 Thermal Energy Transfer in Temperature Processes
- 2-4 Heat Exchangers (Optional Exercise)
- 3-1 Characterization of a Temperature Process in the Heating Mode
- 3-2 Characterization of a Temperature Process in the Cooling Mode
- 4-1 PI Control of a Temperature Process in the Heating Mode
- 4-2 PI Control of a Temperature Process in the Cooling Mode

Pressure, Flow, and Level Processes (Workbook) (8089764 (80897-64))

- 1-1 Familiarization with the Training System
- 2-1 Pressure Measurement
- 2-2 Pressure Losses
- 2-3 Centrifugal Pumps
- 2-4 Centrifugal Pumps in Series and in Parallel (Optional Exercise)
- 3-1 Rotameters and Paddle Wheel Flowmeters
- 3-2 Orifice Plates
- 3-3 Venturi Tubes
- 3-4 Pitot Tubes and Industrial DP Transmitters (Optional Exercise)
- 4-1 Float Switches
- 4-2 Differential Pressure Level Meters
- 4-3 Zero Suppression and Zero Elevation
- 4-4 Wet Reference Legs (Optional Exercise)
- 4-5 Bubblers (Optional Exercise)
- 4-6 Ultrasonic Level Transmitters (Optional Exercise)

- 5-1 Determining the Dynamic Characteristics of a Process
- 6-1 Pressure Process Control
- 6-2 Flow Process Control
- 6-3 Level Process Control
- 6-4 Cascade Process Control (Optional Exercise)
- 6-5 Second-Order Process Control (Optional Exercise)

Pressure, Flow, and Level Process Control Training System (with Bench and Panels) 588655 (6090-B0)



The Pressure, Flow, and Level Process Control Training System (with Bench and Panels) is identical to the Pressure, Flow, and Level Process Control Training System, Model 6090-1, but comprises an unassembled bench with dressing panels that can be used to lock the bench. Just like Model 6090-1, the Pressure, Flow, and Level Process Control Training System (with Bench and Panels) familiarizes students with the fundamentals of instrumentation and process control. It demonstrates the control of pressure, flow, level, temperature, and pH processes. It can also demonstrate advanced process control techniques, such as second-order control, and cascade control when used with a

controller featuring these functions.

List of Equipment

Qty	Description	Model number
1	Pressure, Flow, and Level Processes _____	8089764 (80897-64)
1	Pressure, Flow, and Level Processes (Instructor) _____	8089768 (80897-68)
1	Work Surface (Stainless Steel) _____	587925 (6301-A0)
1	Expanding Work Surface (Large) _____	763446 (6302-00)
1	Bench (Assembled, with Dressing Panels and Lockable Front Door) _____	587929 (6303-C0)
2	Storage/Work Surface _____	582357 (6309-00)
1	DC Power Supply _____	587962 (6360-A0)
1	Multimeter _____	582365 (6394-A0)
1	Pumping Unit _____	595991 (6510-20)
1	Column _____	588211 (6511-00)
2	Hand-Operated Two-Way Valve _____	582368 (6520-00)
1	Solenoid-Operated Two-Way Valve _____	588214 (6521-00)
1	Pressure Transmitter _____	588216 (6540-00)
1	Paddle Wheel Flow Transmitter _____	588222 (6542-00)
1	Rotameter _____	582373 (6550-00)
1	Venturi Tube _____	588232 (6551-00)
1	Orifice Plate _____	588233 (6552-00)
2	Pressure Gauge: Analog – Low Range – 0-100 kPa (0-15 psig) _____	582374 (6553-00)
1	Float Switch _____	588242 (6570-00)
1	Hose Set and Accessory Kit _____	588243 (6590-00)
1	I/O Interface with LVProSim _____	763509 (9065-B0)

List of Manuals

Description	Manual number
Pressure, Flow, and Level Processes (Workbook) _____	8089764 (80897-64)
Pressure, Flow, and Level Processes (Workbook (Instructor)) _____	8089768 (80897-68)

Table of Contents of the Manual(s)

Pressure, Flow, and Level Processes (Workbook) (8089764 (80897-64))

- 1-1 Familiarization with the Training System
- 2-1 Pressure Measurement
- 2-2 Pressure Losses
- 2-3 Centrifugal Pumps
- 2-4 Centrifugal Pumps in Series and in Parallel (Optional Exercise)
- 3-1 Rotameters and Paddle Wheel Flowmeters
- 3-2 Orifice Plates
- 3-3 Venturi Tubes
- 3-4 Pitot Tubes and Industrial DP Transmitters (Optional Exercise)
- 4-1 Float Switches
- 4-2 Differential Pressure Level Meters
- 4-3 Zero Suppression and Zero Elevation
- 4-4 Wet Reference Legs (Optional Exercise)
- 4-5 Bubblers (Optional Exercise)
- 4-6 Ultrasonic Level Transmitters (Optional Exercise)
- 5-1 Determining the Dynamic Characteristics of a Process
- 6-1 Pressure Process Control
- 6-2 Flow Process Control
- 6-3 Level Process Control
- 6-4 Cascade Process Control (Optional Exercise)
- 6-5 Second-Order Process Control (Optional Exercise)

System Specifications

Parameter	Value
Power Requirements	
Current	5 A
Physical Characteristics	
Intended Location	On the floor (stands on casters)
Dimensions (H x W x D)	1830 x 1270 x 700 mm (72 x 50 x 28 in)
Net Weight	TBE

Equipment Description

Work Surface (Stainless Steel) 587925 (6301-A0)

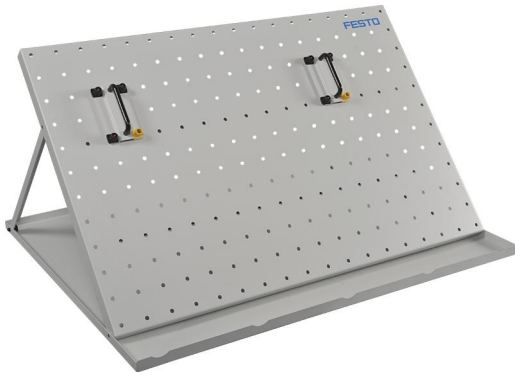

The Work Surface (Stainless Steel) consists in a solid stainless-steel universal drip-tray hinged to a perforated, tiltable work surface on which components can be mounted. The Work Surface (Stainless Steel) can be placed atop a regular worktable or on an optional bench to provide mobility and storage space.

Specifications

Parameter	Value
Physical Characteristics	
Dimensions (H x W x D)	80 x 900 x 700 mm (3 x 35.5 x 27.5 in)
Net Weight	TBE

Expanding Work Surface (Large) 763446 (6302-00)

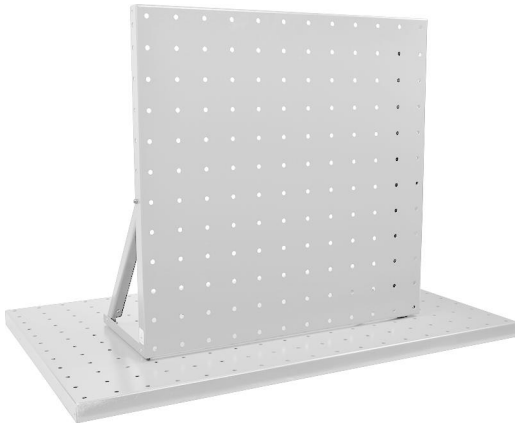

The Expanding Work Surface (Large) consists in a perforated plate that can be mounted on the main Work Surface to increase the work area. The Expanding Work Surface (Large) is two-thirds the main Work Surface in area.

Specifications

Parameter	Value
Physical Characteristics	
Dimensions (H x W x D)	30 x 590 x 590 mm (1 x 23 x 23 in)
Net Weight	5.9 kg (12.8 lb)

Bench (Assembled, with Dressing Panels and Lockable Front Door) 587929 (6303-C0)



The Bench (with Dressing Panels and Lockable Front Door, Assembled) consists of a mobile workstation on which the Work Surfaces, Models 6301 and 6301-1, can be mounted. Four heavy-duty, swiveling, lockable casters allow the bench to be easily moved in the laboratory classroom. The bench has three pairs of side supports over which three Storage/Work Surfaces, Model 6309, can be slid to provide shelving for component storage.

This bench variant is provided already assembled and comprises dressing panels with a lockable front door. These dressing panels fully enclose the bench. The lockable front door consists of two hinged panels with a lock handle to secure the content of the bench.

Specifications

Parameter	Value
Physical Characteristics	
Intended Location	On the floor (stands on casters)
Dimensions (H x W x D)	910 x 850 x 660 mm (35.8 x 33.5 x 26 in)
Net Weight	64 kg (141 lb)

Storage/Work Surface 582357 (6309-00)

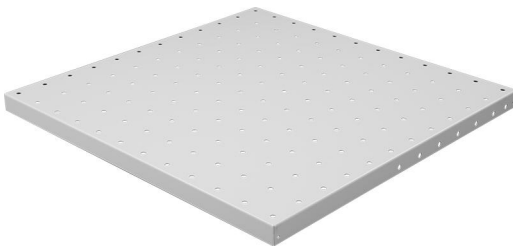

The Storage/Work Surface is a perforated metal plate on which the equipment is placed. Two work surfaces can be joined using Spacers.

Specifications

Parameter	Value
Physical Characteristics	
Dimensions (H x W x D)	30 x 590 x 590 mm (1 x 23 x 23 in)
Net Weight	5 kg (11 lb)

DC Power Supply 587962 (6360-A0)

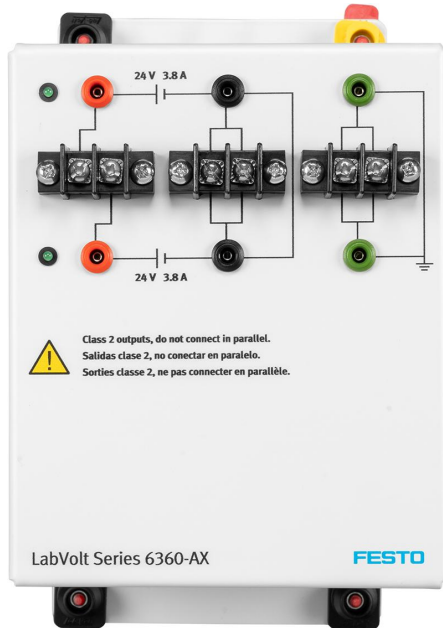

The DC Power Supply converts the ac line voltage into a 24 V dc voltage. The power supply is protected against short circuits by an automatic current/limit circuit.

Specifications

Parameter	Value
Power Requirements	
Voltage	100-240 V ac
Current	4.4 A
Service Installation	Standard single-phase ac outlet
Output	
Voltage	24 V dc
Current	5.0 A
Physical Characteristics	
Dimensions (H x W x D)	120 x 140 x 225 mm (4.7 x 5.5 x 8.9 in)
Net Weight	TBE

Multimeter 582365 (6394-A0)



The Multimeter is used for ac/dc voltage, dc current, and resistance measurements.

Specifications

Parameter	Value
Type	Digital, handheld (portable)
Functions	AC/DC voltage, dc current, resistance, continuity diode test, and battery test
Accuracy	±2.0% or better
Display	3½ digit, liquid-crystal
Features	Safety-recessed test lead connections, low-battery indication, audible continuity, overload protection, mounted on a base that clamps to the work surface using quick-lock fixations
Physical Characteristics	
Dimensions (H x W x D)	170 x 70 x 38 mm (6.7 x 2.75 x 1.5 in)
Net Weight	0.36 kg (0.8 lb)

Conditioning Unit (Single Port) 588111 (6411-A0)



The Conditioning Unit (Single Port) conditions and regulates the pressure of the air supplied to the pneumatic circuits. It consists of a main shutoff valve, filter, a pressure regulator, pressure gauge, sleeve valve, and a muffler. The Conditioning Unit (Single Port) requires compressed air from a central air supply or a portable unit.

Specifications

Parameter	Value
Recommended Compressed Air Supply	
Flow Rate	28 L/min (1 SCFM)
Pressure	207 kPa (30 psi)
Filter Regulator	
Maximum Air Flow Rate	550 L/min (19 SCFM)
Operating Pressure	48-690 kPa (7-100 psi)
Filtration	5 µm (0002 in)
Pressure Gauge	
Diameter	50 mm (2 in)
Operating Pressure	0-690 kPa (0-100 psi)
Physical Characteristics	
Dimensions (H x W x D)	75 x 170 x 120 mm (3 x 6.7 x 4.7 in)
Net Weight	1.6 kg (3.6 lb)

Pumping Unit 595991 (6510-20)

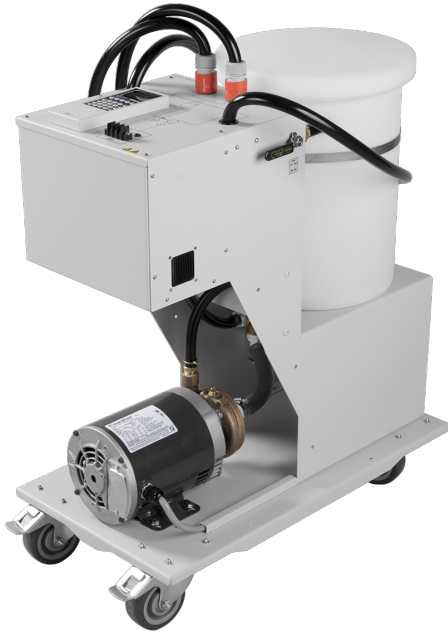

The Pumping Unit consists of a centrifugal variable-speed pump having a flow of 0-12 l/min (0-3.2 gal US/min) and a maximum pressure of 100 kPa, gauge (14.5 psig). The pump motor has a rated speed of 3600 rpm at 60 Hz and 3000 rpm at 50 Hz, with a power of 0.37 kW (0.5 hp) at 60 Hz and 0.25 kW (0.33 hp) at 50 Hz.

The Pumping Unit includes great features such as a built-in Powerflex 525 ac drive from Allen-Bradley. This ac motor drive has an output voltage of 0-230 V ac, an output frequency of 0-240 Hz, and is controlled using either 4-20 mA signals or an Ethernet/IP digital communication with Allen-Bradley PLC's. The Pumping Unit also features a convenient communication interface to configure and monitor all the drive's parameters.

The nominal current of the Pumping Unit is 3 A at 120V 60 Hz and 1.5 A at 220-240V 50 Hz.

The reservoir of the Pumping Unit has a capacity of 18.9 l (5 gal US) and comprises two inlet valves (two-way, manually operated), as well as an outlet valve (three-way, two-position, manually operated). A

stainless steel vortex breaker prevents air aspiration in the pump's suction.

Column 588211 (6511-00)



The Column consists of a column with a height of 68 cm (26.8 in), a diameter of 11.5 cm (4.5 in), and a capacity of 3.8 l (1 gal US). It has two pressure taps: one at the bottom and one at the top of the column, with quick-connect ball check sockets. The Column is fitted with an integrated bubbler tube, a level measurement ruler graduated in both centimeters and inches, and a removable cap allowing the insertion of level measuring instruments into the column.

Specifications

Parameter	Value
Height	68 cm (26.8 in)
Diameter	11.5 cm (4.5 in)
Capacity	3.8 L (1 gal US)
Pressure Taps	Two, one at the bottom and one at the top of the column, with quick-connect ball check sockets.
Other Characteristics	
Other Characteristics	Integrated bubbler tube
	Level measurement ruler graduated in both centimeters and inches
	Removable cap allowing insertion of level measuring instruments into the column

Metering Pump 588212 (6512-00)



The Metering Pump is a metering pump whose pump motor has an excitation voltage of 0-12 V dc and a nominal current of 2 A. The pump has a flow of 0-2.52 L/min (0-0.67 gal US/min), a maximum pressure of 145 kPa (21 psi), and a maximum temperature of 93°C (200°F)

Specifications

Parameter	Value
Pump Motor	
Excitation Voltage	0-12 V dc
Current	2 A
Pump	
Flow	0-2.52 L/min (0-0.67 gal US/min)
Maximum Pressure	145 kPa (21 psi)
Maximum Temperature	93°C (200°F)

Chemical Tank 588213 (6513-00)



The Chemical Tank consists of a tank with a capacity of 2 L (0.53 gal). The cap check-valve of the tank has a closing pressure of 97 Pa (0.014 psi). The tank has a quick-connect coupling.

Specifications

Parameter	Value
Capacity	2 L (0.53 gal)
Cap Check-Valve	97 Pa (0.014 psi) closing pressure
Coupling	Quick connect
Physical Characteristics	
Dimensions (H x W x D)	TBE

Parameter	Value
Net Weight	TBE

Hand-Operated Two-Way Valve 582368 (6520-00)

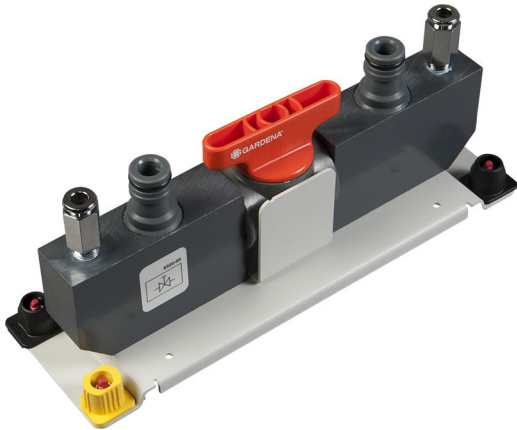

The Hand-Operated Two-Way Valve controls fluid flow in an on or off fashion and also helps when necessary to ensure that a system component is safely isolated from other parts of the system.

Specifications

Parameter	Value
Valve	
Type	Hand-operated, two-way, ball
Inlet and Outlet Diameter	1.3 cm (0.5 in)
Pressure Taps	Two, one at the inlet and one at the outlet, with quick-connect ball check sockets.
Physical Characteristics	
Dimensions (H x W x D)	22 x 7 x 9.5 cm (8.7 x 2.75 x 3.75 in)
Net Weight	0.59 kg (1.3 lb)

Solenoid-Operated Two-Way Valve 588214 (6521-00)

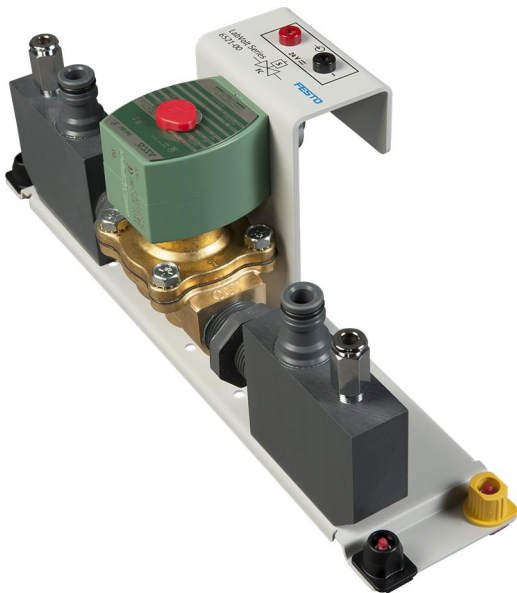

The Solenoid-Operated Two-Way Valve controls fluid flow in an ON or OFF fashion and also helps to ensure that a system component is safely isolated from other parts of the system, when necessary.

Specifications

Parameter	Value
Type	Two-way, normally closed, spring-return
Solenoid	
Voltage	24 V dc
Current	0.48 A
Power	11.6 W
Water Pressure	34.5-690 kPa, gauge (5-100 psig)
Pressure Taps	Two, one at the inlet and one at the outlet, with quick-connect ball check sockets.

Heating Unit 582369 (6530-00)



The Heating Unit consists of a heating unit with a maximum power of 1.2 kW (1.14 Btu/s) that is controlled manually using a built-in adjustment knob or externally using 0-5 V or 4-20 mA signals. It has two temperature measurement ports (inlet/outlet).

The Heating Unit is protected using two high-temperature cut-out switches: one with an automatic reset and one with a manual reset. The Heating Unit is also protected using a current breaker.

Specifications

Parameter	Value
Heating Unit	
Type	Hydronic heating unit
Power Requirements	
Current	10 A
Service Installation	Standard single-phase ac outlet
Protection	
Type	High-temperature cut-out switch with manual reset
Temperature	Between 55°C and 75°C (131°F and 167°F)
Current	Breaker
Heating Power	
Maximum	1.2 kW (1.14 Btu/s)
Control	Manual with built-in adjustment knob or external using 0-5 V on 4-20 mA signals
Temperature Measurement Ports	2 inlets/outlets
Physical Characteristics	
Dimensions (H x W x D)	34 x 37 x 9.5 cm (13.375 x 14.6 x 3.75 in)
Net Weight	5.67 kg (12.5 lb)

Radiator 582372 (6531-00)

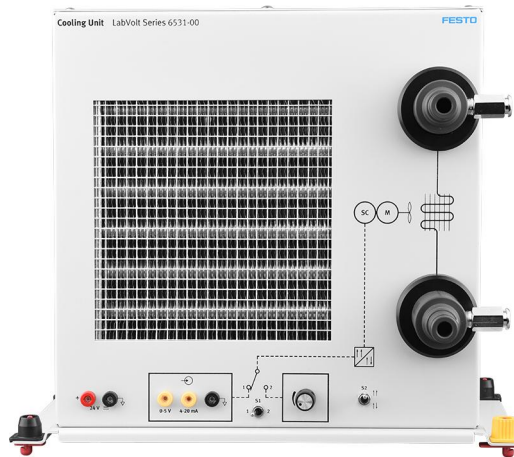

The radiator contains a 1.06 m² (11.41 ft²) radiator element that acts as a heat exchanger to transfer thermal energy from water to air. The unit allows manual blower-speed control using either a built-in adjustment knob or external signals (0-5 V or 4-20 mA). The maximum air flow rate is 3060 L/min (106 ft³/min). The dual blower consists of two electric motors with fan blades that are powered by a 24 V dc, 2.4 A power supply output.

Specifications

Parameter	Value
Cooling Unit	
Type	Forced-air cooling coil with variable-speed fans
Fans	
Quantity	2
Ratings	
Voltage	24 V dc
Current	0.4 A dc
Maximal Air Flow Rate	3060 L/min (106 ft ³ /min)
Temperature Measurement Ports	2 inlets/outlets
Fan Speed Control	
Direction	Direct or reverse
Modes	Manual with built-in adjustment knob or external using 0-5 V or 4-20 mA signals.
Physical Characteristics	
Dimensions (H x W x D)	32 x 17 x 27.3 cm (12.6 x 6.7 x 10.75 in)
Net Weight	5.08 kg (11.2 lb)

Heat Exchanger 588215 (6532-00)



The Heat Exchanger consists of a brazed plate heat exchanger, with a nominal surface of 0.21 m² (2.3 ft²) and 4 channels for side A and 3 for side B, for a total of 8 plates.

Specifications

Parameter	Value
Type of exchanger	

Parameter	Value
Type of Exchanger	Brazed plate
Nominal Surface	0.21 m ² (2.3 ft ²)
Number of Channels	4 channels for side A and 3 for side B, for a total of 8 plates

Pressure Transmitter 588216 (6540-00)



The Pressure Transmitter consists of a pressure transmitter having output signals of 4-20 mA. It has a zero adjustment of 90% of the calibrated span, a span adjustment of 2.5-103 kPa (10-414 in H₂O), a proof pressure of 310 kPa, gauge (45 psig), an operating temperature of 5-70°C (41-158°F), and a compensated temperature of 0-50°C (32-122°F). Its linearity is 1% of the full scale, while its hysteresis is 0.2% of the full scale. The supply voltage of the Pressure Transmitter is 24 V dc.

Specifications

Parameter	Value
Supply Voltage	24 V dc
Output Signals	4-20 mA
Zero Adjustment	90% of calibrated span
Span Adjustment	2.5-103 kPa (10-414 inH ₂ O)
Proof Pressure	310 kPa, gauge (45 psig)
Operating Temperature	5-70°C (41-158°F)
Compensated Temperature	0-50°C (32-122°F)
Linearity	1% of full scale
Hysteresis	0.2% of full scale

Thermocouple Temperature Transmitter 588219 (6541-00)



The Thermocouple Temperature Transmitter is a thermocouple temperature transmitter having four J-type thermocouple probes with cold-junction compensation and a built-in calibration source. Its outputs are controlled using 0-5 V dc or 4-20 mA signals and are calibrated at 100 mV/°C (56 mV/°F). The supply voltage of the Thermocouple Temperature Transmitter is 24 V dc.

The Thermocouple Temperature Transmitter has a fixed calibration mode with the zero at 0°C (32°F) and a span of 100°C (212°F). It also has a variable calibration mode with the zero adjustable between 0°C and 50°C (32°F and 122°F) and a span adjustable between 15°C and 30°C (27°F and 54°F) above the temperature set by zero adjustment.

Specifications

Parameter	Value
Supply Voltage	24 V dc
Inputs	Four J-type thermocouple probes with cold-junction compensation
Calibration Source	Built-in
Outputs	
Control	0-5 V dc, 4-20 mA
Calibrated	100 mV / °C (56 mV / °F)
Fixed Calibration Mode	
Zero	0°C (32°F)
Span	100°C (212°F)
Variable Calibration Mode	
Zero	Adjustable between 0 and 50°C (32 and 122°F)
Span	Adjustable between 15 and 30°C (27 and 54°F) above temperature set by ZERO adjustment.

Paddle Wheel Flow Transmitter 588222 (6542-00)



The Paddle Wheel Flow Transmitter is a paddle wheel flow transmitter with two outputs controlled using 0-5 V dc or 4-20 mA signals. The first output is a voltage output calibrated at 1 V per l/min (3.85 V per gal US/min). The second output is a frequency output calibrated at 22.1 Hz per l/min (85 Hz per gal US/min).

The Paddle Wheel Flow Transmitter has a span adjustment of 7-9.5 l/min (1.8-2.5 gal US/min), a linearity of $\pm 1.5\%$ of the full scale, a maximum pressure of 175 kPa (25 psig), and an operating temperature of 5-70°C (41-158°F). The supply voltage of the Paddle Wheel Flow Transmitter is 24 V dc.

Specifications

Parameter	Value
Supply Voltage	24 V dc
Outputs	
Control	0-5 V dc, 4-20 mA
Calibrated	Two, one voltage output of 1 V per L/min (3.85 V per gal US/min), and 0-5 V frequency output of 22.1 Hz per L/min (85 Hz per gal US/min).
Span Adjustment	7-9.5 L/min (1.8-2.5 gal US/min)
Linearity	$\pm 1.5\%$ of full scale
Maximum Pressure	175 kPa (25 psig)
Operating Temperature	5-70°C (41-158°F)

RTD Temperature Transmitter 588225 (6543-00)



The RTD Temperature Transmitter is an RTD temperature transmitter with a single three-wire 100 Ω platinum probe and a built-in calibration source. Its outputs are controlled using 0-5 V dc or 4-20 mA signals and are calibrated at 100 mV/°C (56 mV/°F). The supply voltage of the RTD Temperature Transmitter is 24 V dc.

The RTD Temperature Transmitter has a fixed calibration mode with the zero at 0°C (32°F) and a span of 100°C (212°F). It also has a variable calibration mode with the zero adjustable between 0°C and 50°C (32°F and 122°F) and a span adjustable between 15°C and 30°C (27°F and 54°F) above the temperature set by zero adjustment.

Specifications

Parameter	Value
Supply Voltage	24 V dc
Input	
Number	One
Type	Three-wire 100 Ω platinum probe
Calibration Source	Built-in
Outputs	
Control	0-5 V dc, 4-20 mA
Calibrated	100 mV / °C (56 mV / °F)
Fixed calibration mode	
Zero	0°C (32°F)
Span	100°C (212°F)
Variable calibration mode	
Zero	Adjustable between 0 and 50°C (32 and 122°F)
Span	Adjustable between 15 and 30°C (27 and 54°F) above temperature set by ZERO adjustment.

pH Transmitter 588228 (6544-00)



The pH Transmitter consists of a pH transmitter with a single pH probe and a built-in calibration source. Its outputs are controlled using 0-5 V dc or 4-20 mA signals and are calibrated at 1 V/pH unit. The supply voltage of the pH Transmitter is 24 V dc.

Specifications

Parameter	Value
Supply Voltage	24 V dc

Parameter	Value
Input	One pH probe
Calibration Source	Built-in
Outputs	
Control	0-5 V dc, 4-20 mA
Calibrated	1 V / pH unit

Ultrasonic Level Transmitter 588231 (6545-00)



The Ultrasonic Level Transmitter consists of an ultrasonic level transmitter with output signals controlled using 4-20 mA inputs and two switches. Its optimum range is 64 mm - 2 m (2.5 - 80 in), its maximum range is 3 m (10 feet). It has a digital resolution of 0.086 mm (0.0034 in) and an analog resolution of 4099 steps over the 4-20 mA signal. The Ultrasonic Level Transmitter has a repeatability greater than ± 0.76 mm (0.03 in) or 0.1% of the target distance. Its operating temperature is -40 to 70°C (-40 to 158°F) and it is temperature compensated. The update rate of the Ultrasonic Level Transmitter is 50 ms.

Specifications

Parameter	Value
Power Requirements	
Voltage	24 V dc
Current	0.15 A
Output Signals	
Control	4-20 mA
Switches	2
Optimum Range	64 mm - 2 m (2.5 - 80 in)
Maximum Range	3 m (10 ft)
Resolution	
Digital	0.086 mm (0.0034 in)
Analog	4099 steps over the 4-20 mA signal
Repeatability	Greater of ± 0.76 mm (0.03 in) or 0.1% of target distance
Operating Temperature	-40 to 70°C (-40 to 158°F) / Temperature compensated
Update Rate	50 ms

Rotameter 582373 (6550-00)



The rotameter is an analog device that measures the flow rate of a fluid as the material pushes on a floating indicator. Rotameters help to ensure that system fluid flow rates are normal and passageways are not excessively restricted or blocked, which could dramatically raise fluid pressure. The rotameter is calibrated in both liters per minute (L/min) and gallons per minute (gal/min), and the clear-tapered tube permits visual inspection of the internal fluid and observation of trapped air bubbles, dirt, and debris within a system loop.

Specifications

Parameter	Value
Rotameter	
Type	Tapered tube with float indicator
Inlet and Outlet Diameter	1.3 cm (0.5 in)
Flow Range	2-20 L/min (0.5-5 gal US/min)
Mounting	Vertical
Accuracy	±5% of full scale
Pressure Taps	Two, one at the inlet and one at the outlet, with quick-connect ball check socket.
Physical Characteristics	
Dimensions (H x W x D)	36.83 x 7 x 10.48 cm (14.5 x 2.75 x 4.125 in)
Net Weight	1.8 lb (0.82 kg)

Venturi Tube 588232 (6551-00)

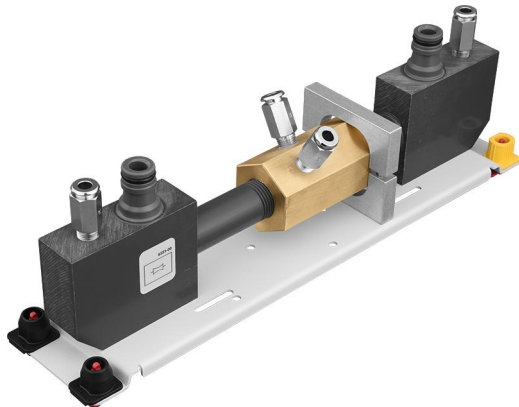

The Venturi Tube, Model 6551, consists of a venturi tube with an inlet and outlet diameter of 1.3 cm (0.5 in), a β ratio of 0.37, a flow range of 1.9-18.9 l/min (0.5-5.0 gal US/min), and a pressure drop of 0.25-65 kPa (1-260 inH₂O). The Venturi Tube has two pressure taps, one at the inlet and one at the outlet, with quick-connect ball check sockets.

Specifications

Parameter	Value
Inlet and Outlet Diameter	1.3 cm (0.5 in)
β Ratio	0.37
Flow Range	1.9-18.9 L/min (0.5-5.0 gal US/min)
Pressure Drop	0.25-65 kPa (1-260 inH ₂ O)
Pressure Taps	Two, one at the inlet and one at the outlet, with quick-connect ball check sockets.
Physical Characteristics	
Dimensions (H x W x D)	TBE

Parameter	Value
Net Weight	TBE

Orifice Plate 588233 (6552-00)

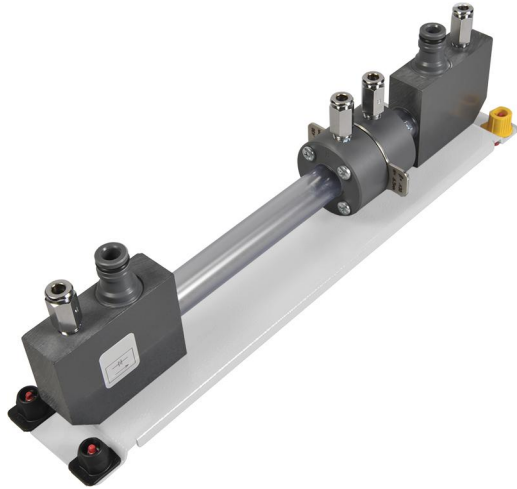

The Orifice Plate, Model 6552, consists of an orifice plate with an inlet and outlet diameter of 1.3 cm (0.5 in), a β ratio of 0.43, an orifice diameter of 6.53 mm (0.257 in), a flow range of 1.9-18.9 l/min (0.5-5.0 gal US/min), and a pressure drop of 0.25-65 kPa (1-260 in H₂O). The Orifice Plate has two pressure taps, one at the inlet and one at the outlet, with quick-connect ball check sockets.

Specifications

Parameter	Value
Inlet and Outlet Diameter	1.3 cm (0.5 in)
β Ratio	0.43
Orifice Diameter	6.53 mm (0.257 in)
Flow Range	1.9-18.9 l/min (0.5-5.0 gal US/min)
Pressure Drop	0.25-65 kPa (1-260 inH ₂ O)
Pressure Taps	Two, one at the inlet and one at the outlet, with quick-connect ball check sockets.
Physical Characteristics	
Dimensions (H x W x D)	TBE
Net Weight	TBE

Pressure Gauge: Analog – Low Range – 0-100 kPa (0-15 psig) 582374 (6553-00)



The Pressure Gauge provides a direct reading of the pressure in one of many convenient measurement units. It features two interconnected pressure ports, and is equipped with a mounting bracket for simple installation on the workstation.

Specifications

Parameter	Value
Pressure Gauge	
Type	Analog, bourdon tube
Range	0-100 kPa (0-15 psig)
Accuracy	±3% of full scale
Dial Diameter	6.4 cm (2.5 in)
Pressure Taps	Two inlets with quick-connect ball-check socket
Physical Characteristics	
Dimensions (H x W x D)	11.43 x 12 x 10.48 cm (4.5 x 4.7 x 4.125 in)
Net Weight	0.5 kg (1.1 lb)

Pitot Tube 588237 (6554-00)

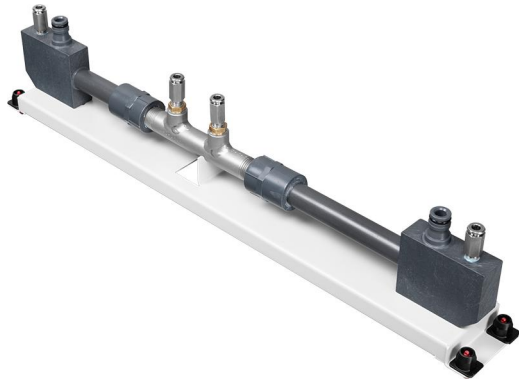

The Pitot Tube consists of a pitot tube with a nominal pipe size of 1.27 cm (0.5 in), schedule 40. Its instrument connection size is 0.635 cm (0.25 in) FNPT, and its maximal pressure differential is 400 in H₂O (99.6 kPa, 14.45 psi).

Specifications

Parameter	Value
Nominal Pipe Size	1.27 cm (0.5 in) - Schedule 40
Instrument Connection Size	0.635 cm (0.25 in) FNPT
Maximal Pressure Differential	400 in H ₂ O (14.45 psi, 99.6 kPa)

Metering Pump Drive 588238 (6560-00)

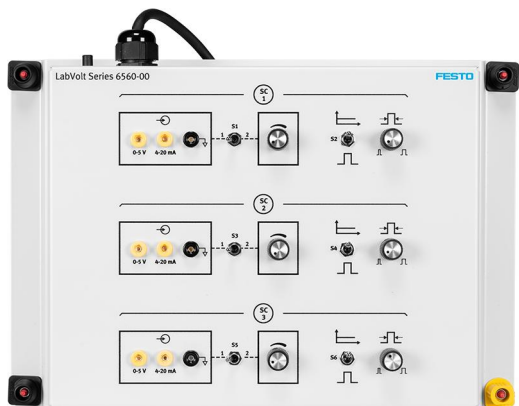

The Metering Pump Drive consists of a metering pump drive with three 0-5 V dc or 4-20 mA inputs and an output voltage of 0-10 V dc. It is controlled using three 0-5 V dc or 4-20 mA control inputs. It can operate in either continuous mode or pulsed mode.

Specifications

Parameter	Value
Power Requirements	
Current	0.5 A

Parameter	Value
Service Installation	Standard single-phase ac outlet
Inputs	
Number	3
Inputs	0-5 V or 4-20 mA
Output Voltage	0-10 V dc
Control Input	
Number	3
Voltage	0-5 V dc
Current	4-20 mA
Mode	Continuous, pulsed

Set Point Device 588241 (6561-00)



The Set Point Device consists of a set point device with a supply voltage of 24 V dc and three 0-5 V dc outputs. It is controlled using two built-in adjustment knobs and one toggle switch.

Specifications

Parameter	Value
Supply Voltage	24 V dc
Output	
Number	3
Voltage	0-5 V dc
Control	Two built-in adjustment knobs, one toggle switch
Physical Characteristics	
Dimensions (H x W x D)	TBE
Net Weight	TBE

Float Switch 588242 (6570-00)



The Float Switch consists of a reed-relay float switch with magnet-equipped float. Its mounting is vertical and inside the level column. The reed contact is hermetically sealed and normally closed, with a positioning range of 25 cm (10 in). The Float Switch operates at atmospheric pressure.

Specifications

Parameter	Value
Type	Reed-relay, with magnet-equipped float
Mounting	Vertical, inside the level column
Reed Contact	
Type	Hermetically sealed, normally closed
Positioning Range	25 cm (10 in)
Operating Pressure	Atmospheric pressure

Hose Set and Accessory Kit 588243 (6590-00)



The Hose Set and Accessory Kit includes the following:

- Six PVC hoses, 1.3 cm (0.5 in) inside diameter, garden-type quick-connect fittings, 303 kPa, gauge (44 psig) maximum pressure
- 6 mm (0.25 in) tubing
- Tube cutter
- Electrical leads
- Quick-connect fittings

Specifications

Parameter	Value
Hoses	
Number	6
Material	PVC
Inside Diameter	1.3 cm (0.5 in)
Fittings	Garden-type, quick-connect
Maximum Pressure	303 kPa, gauge (44-psig)
Accessories	
Includes:	6 mm (0.25 in) tubing
	Tube cutter
	Electrical leads
	Quick-connect fittings

pH Process Control Accessories 588244 (6591-00)



The pH Process Control Accessories, Model 6591, includes the following:

Laboratory glassware

- Two beakers, one with 100-ml (3.4-oz) capacity and one with 600-ml (20.3-oz) capacity
- Two graduated cylinders, one with 100-ml (3.4-oz) capacity and one with 10-ml (0.3oz) capacity
- Volumetric flask with a 2000-ml (67.63-oz) capacity

- Two chemical splash goggles
- Tubing and hoses connectors
- Spatula

- Column cap
- Dropping bottle
- Disposable transfer pipettes
- Current calibrator
- Precision scale
- Two funnels
- 2 mm plugs
- Tubing holder

Specifications

Parameter	Value
Laboratory Glassware	
Beaker	Two, one with 100 ml (3.4 oz) capacity and one with 600 ml (20.3 oz) capacity
Graduated Cylinder	Two, one with 100 ml (3.4 oz) capacity and one with 10 ml (0.3 oz) capacity
Volumetric Flask	2000 ml (67.63 oz) capacity
Miscellaneous	
Includes:	Chemical splash goggles (2)
	Tubing and hoses connectors
	Spatula
	Column cap
	Dropping bottle
	Disposable transfer pipettes
	Current calibrator
	Precision scale
	Funnels (2)
	2 mm plugs
	Tubing holder

Instrumentation Pipe 588245 (6592-00)



The Instrumentation Pipe is a vertical pipe used to install instruments at the appropriate height and close to the point of measurement. The Instrumentation Pipe replicates the common industrial practice of installing a measuring instrument directly on the process pipe or on an adjacent one. The Instrumentation Pipe must be installed on a perforated work surface.

Specifications

Parameter	Value
Physical Characteristics	
Dimensions (H x W x D)	TBE
Net Weight	TBE

pH Process Control Consumables for 6090 588246 (6599-00)



The pH Process Control Consumables for 6090 set contains the following:

1 L (33.8 oz) of the following solutions:

- Sodium Hydroxide Standard Solution 1.0 N (x 2)
- Hydrochloric Acid Solution 1.0 N
- Phenol Red Aqueous Solution 0.05%

- Phosphoric Acid 1.0 N Solution

- 500 ml (16.9 oz) of the following solutions:

- Potassium Chloride Solution

- Buffer Solution pH 4.0

- Buffer Solution pH 7.0

- Buffer Solution pH 10.0

- Acetic Acid 5% (Vinegar)

- 500 g (1.1 lb) of Sodium Bicarbonate (Baking Soda)

Specifications

Parameter	Value
Sodium Hydroxide Standard Solution	
Quantity	2 x 1 L (33.8 oz) bottle
Concentration	1.0 N
Hydrochloric Acid Solution	
Quantity	1 x 1 L (33.8 oz) bottle
Concentration	1.0 N
Phenol Red Aqueous Solution	
Quantity	1 x 1 L (33.8 oz) bottle
Concentration	0.05%
Phosphoric Acid Solution	
Quantity	1 x 1 L (33.8 oz) bottle
Concentration	1.0 N
Potassium Chloride Solution	
Quantity	1 x 500 ml (16.9 oz) bottle
Buffer Solution	
Quantity	3 x 500 ml (16.9 oz) bottle
pH	One bottle with pH 4.0, one bottle with pH 7.0, one bottle with pH 10.0
Acetic Acid (Vinegar)	
Quantity	1 x 500 ml (16.9 oz) bottle
Concentration	5%
Sodium Bicarbonate (Baking Soda)	

Parameter	Value
Quantity	1 x 500 g (1.1 lb) box
Latex Gloves	
Number	100

I/O Interface with LVProSim 763509 (9065-B0)



The I/O Interface is a module used to interface with a computer for data acquisition and PID control of a real process. The I/O Interface provides interconnection between the process devices and the computer. It performs analog signal and digital signal conversions and sends the information to LVProSim, a process control software included with the interface.

The I/O Interface has four 4-20 mA analog inputs, two 4-20 mA analog outputs, four 24 V digital inputs, and two relays (1A 30V DC). It connects to a computer through a USB cable and must be powered using a 24 V dc power supply.

The I/O Interface requires LVProSim, a process control software specially designed to connect to the interface and collect data at

a fast sampling rate (100 ms). LVProSim has two main features: it can operate as a process controller and a generic process simulator. LVProSim's modern web interface makes it easy to use, helping students focus on learning process control.

When used as a controller, LVProSim monitors data from the I/O Interface and applies a standard PID algorithm to determine the appropriate response. LVProSim can either control two processes simultaneously or use its two controllers in cascade mode. LVProSim also offers a set of mathematical functions to treat inputs and outputs signals.

The simulation mode allows students to model first-order or second-order processes. This mode encourages students to explore the various characteristics of a process such as its time constants, gain, and dead time. Once a generic process simulation is running, students can connect the simulated process to a controller and test different control schemes. Contrary to the data acquisition mode, the simulation mode does not require the I/O Interface. Therefore, students can experiment with the software on their own computer.

Note that, although the I/O interface is designed to be used with LVProSim, its data acquisition interface is compatible with Linux[®], MATLAB[®], and NI LabVIEW[™]. Raw data can be acquired using these software/platform, given the appropriate drivers are installed.

PID Controller



LVProSim uses a non-interacting ideal algorithm to control processes. Two controllers are available. They can be used to control two independent processes or they can be coupled via a dynamic set point for cascade control. The sampling interval and the controller action (director or reverse) are user selectable. A square-root extracting function permits linearization of measured signals and other mathematical functions are available as well.

The proportional (P), integral (I), and derivative (D) contributions on the final controller output can be displayed independently on the trend recorder. Meters can be added to the interface to display monitored variables in real time.

Trend Recorder

The LVProSim trend recorder can be used to plot different variables such as the set points, output signals, signals from the proportional, integral, and derivative contributions, measured and controlled variables, the function generator output signal, etc. A pause button can be used to stop the recorder at any time. The trend recorder can be scrolled backward and forward in time, with automatic time tracking during scrolling. Data can be exported to CSV format to be later imported into a spreadsheet software for detailed analysis and accurate measurement of the process characteristics.

Function Generator

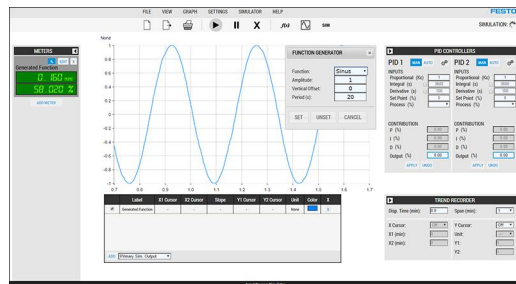

The function generator can produce a sine, square, triangle, or step signal. The signal from the function generator can be used as the controller set point or to perform manual control of a process device. When using LVProSim in the simulation mode, the generator signal can be used as the controller set point, the disturbance signal, or

the controller output signal.

Data Acquisition

Through continuous acquisition of process data via the I/O Interface, LVProSim can:

- achieve digital PID control of the process
- be used as the primary and secondary controller of a cascade control loop
- be used as a process simulator
- be used as a general purpose data acquisition system

Generic Process Simulator

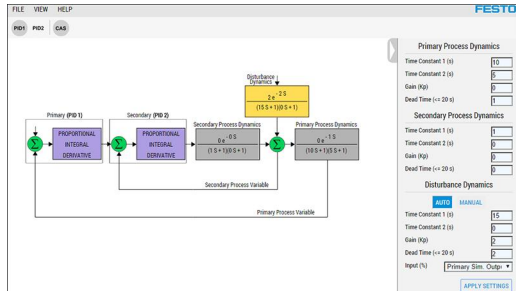

The generic process simulator provides simplified simulation to introduce basic concepts of process control. The simulator can be configured as first or second order process, with or without dead time. The disturbance can be configured as first order. The process and disturbance have variable gains.

Specifications

Parameter	Value
Supply Voltage	24 V
Inputs	
Analog	4 x 4-20 mA
Digital	4 x 24 V
Outputs	
Analog	2 x 4-20 mA
Digital	2 x 24 V
Analog/Digital Converter	
Resolution	12 bits
Digital/Analog Converter	
Resolution	8 bits
Relay	
Quantity	2
Current	1 A
Voltage	30 V DC
Computer Requirements	A currently available personal computer with USB 2.0 or 3.0 port, running under one of the following operating systems: Windows® 7, Windows® 8 or Windows® 10 .
Physical Characteristics	
Dimensions (H x W x D)	55 x 120 x 172 mm (2.2 x 4.7 x 6.8 in)
Net Weight	1 kg (2.2 lb)

Differential-Pressure Transmitter (HART, Medium Range) 588335 (46929-00)



The Differential-Pressure Transmitter (HART, Medium Range) is designed to operate in a range going from a difference of 0 kPa (0 psi) to an absolute difference of 300 kPa (45 psi). It is compatible with the HART communication protocol.

Specifications

Parameter	Value
Supply Voltage	24 V dc
Output Signals	
Current	4-20 mA
Communication Protocol	HART
Nominal Range	± 3 bar, ± 300 kPa, ± 45 psi
Accuracy	$\pm 0.075\%$ of the span (i.e., ± 0.5 kPa or ± 0.07 psi)
Damage-Threshold Pressure	Up to 420 bar (6300 psi) on a single side, 630 bar (9450 psi) on both sides

Pneumatic Control Valve 582424 (46950-B0)



The Pneumatic Control Valve is an industrial bronze control globe valve designed for pressure, flow, level, and temperature control applications. This reliable valve features a durable construction, tight shutoff, and good control characteristics. The valve is of the equal percentage type and is normally open.

This model includes a current-to-pressure converter which transforms a 4-20 mA input signal into a pneumatic output signal sent to the actuator of the control valve.

The Pneumatic Control Valve features a bypass that can be used to control the liquid flow manually.

Manual

Description	Manual number
Control Valves (User Guide)	585145 (86001-E0)

Table of Contents of the Manual(s)

Control Valves (User Guide) (585145 (86001-E0))

- 1 Basic Control Valve Theory
- 2 Basic Control Valve (46950-B)
- 3 Pneumatic Control Valve with a Positioner (46950-A)
- 4 Control Valve with DVC2000 (46950-0)
- 5 Control Valve with DVC6000 – HART/FF (46950-E/-D)
- 6 Control Valve with DVC6200 – HART/FF (46950-E/-D)
- 7 Electric Control Valve (46950-C)

Specifications

Parameter	Value
Input Signal	4-20 mA
Actuator Pressure Range	20-90 kPa (3-13 psi)
Type of valve	Globe, equal percentage, normally open

Optional Equipment Description

Compressor for MecLab (Optional) 556275 (5562-75)



Compressor for MecLab. Sound pressure of only 53 dB (A) , therefore well suited for use in classrooms

Supplies up to 4 MecLab stations. Complete with pressure regulator, water separator, 5 m of 6 mm tubing, 3 T-distributors.

- Pressure: maximum 400 kPa (4 bar)
- Suction capacity: 20 l/min
- Reservoir capacity: 2.5 l

- Dimensions: 310 x 150 x 370 mm Version: 230 V/50 Hz

Version: 120 V/60 Hz

With IEC power cable to NEMA 5-15 suitable for: US, CA, Central America, BR, CO, YU, EC, KR, TW, TH, PH, JP

Compressor for MecLab[®], Design: 110 V/60 Hz, 70 W

Mains cable suitable for US, CA, Central America, BR, CO, YU, EC, KR, TW, TH, PH, JP

Compressor for MecLab[®], Design: 110 V/60 Hz, 70 W

Mains cable suitable for US, CA, Central America, BR, CO, YU, EC, KR, TW, TH, PH, JP

**Personal Computer (Optional)
579785 (8990-00)**



The Personal Computer consists of a desktop computer running under Windows® 10. A monitor, keyboard, and mouse are included.

Specifications

Parameter	Value
Power Requirements	
Current	2 A
Service Installation	Standard single-phase ac outlet

**Rust Inhibitor Solution (Optional)
777198 (38096-00)**

The Rust Inhibitor Solution contains an industrial-grade solution used to prevent the formation of rust.

Specifications

Parameter	Value
Rust Inhibitor Solution	
Quantity	240 ml (8 oz)

**Antibacterial Solution (Optional)
8060736 (38097-00)**

The Antibacterial Solution is a solution specially designed for time-released protection of the water.

Specifications

Parameter	Value
Antibacterial Solution	
Quantity	240 ml (8 oz)

Touch-Screen Computer – Large (Optional) 589677 (46299-A0)



The Touch-Screen Computer is a solution for saving space in the classroom. It features a large 23-inch touch-screen and a high-speed processor. It can be installed on a full-motion mount, model 3451-A0 or 3451-B0, on the Instrumentation Workstation to maximize desk space.

FactoryTalk View ME Studio (Educational) (Optional) 588384 (46968-00)

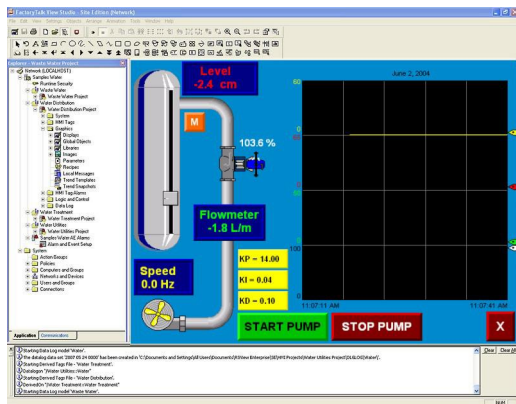

FactoryTalk View is a Windows-based application suite, produced by Rockwell Software, which simplifies the creation of graphic human-machine interfaces (HMI), such as operator interface solutions, to monitor and control machines and small processes. This versatile suite is compatible with a wide array of PLCs constitutes a distributed control system development solution of choice.

HMI applications are developed and edited using FactoryTalk View Studio, which also has limited runtime capabilities to test your interface. A completed application can be loaded directly on a Touch Screen Graphic Terminal, Model 5922 or 46973, as it includes a built-in runtime software. Your applications can also

be designed to run on a computer, but doing so requires the purchase of FactoryTalk View Machine Edition Station Runtime.

Available versions:

- 46968-0 FactoryTalk View ME Studio (Educational)
- 46968-2 FactoryTalk View ME Station (Educational)
- 46968-A FactoryTalk View ME Studio (Commercial)
- 46968-C FactoryTalk View ME Station (Commercial)

Manual

Description

Human-Machine Interfaces (User Guide)

Manual number

585116 (85985-E0)

Specifications

Parameter	Value
Computer Requirements	A currently available personal computer running under one of the following operating systems: Windows® 7 or Windows® 8.

FactoryTalk View ME Station (Educational) (Optional) 588397 (46968-20)

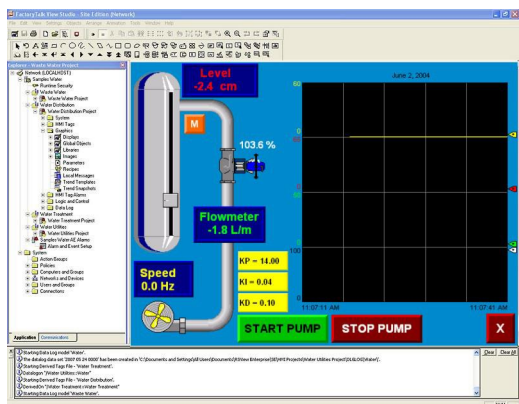

FactoryTalk View is a Windows-based application suite, produced by Rockwell Software, which simplifies the creation of graphic human-machine interfaces (HMI), such as operator interface solutions, to monitor and control machines and small processes. This versatile suite is compatible with a wide array of devices, including PLCs and Foxboro controllers, and constitutes a distributed control system development solution of choice.

HMI applications are developed and edited using FactoryTalk View Studio, which also has limited runtime capabilities to test your interface. A completed application can be loaded directly on a Touch Screen Graphic Terminal, Model 5922 or 46973, as it includes a built-in runtime software. Your applications can also

be designed to run on a computer, but doing so requires the purchase of FactoryTalk View Machine Edition Station Runtime.

A bundle (Model 46968-1 or -B) consisting of FactoryTalk View Studio and a Foxboro OPC server is available to enable communication and data exchange between a Foxboro controller (Model 46960) and a computer.

Available versions:

- 46968-0 FactoryTalk View ME Studio (Educational)
- 46968-1 FactoryTalk View ME Studio (with Foxboro OPC server, Educational)
- 46968-2 FactoryTalk View ME Station (Educational)
- 46968-3 FactoryTalk View ME Station (with Foxboro OPC server, Educational)
- 46968-A FactoryTalk View ME Studio (Commercial)
- 46968-B FactoryTalk View ME Studio (with Foxboro OPC Server, Commercial)
- 46968-C FactoryTalk View ME Station (Commercial)
- 46968-D FactoryTalk View ME Station (with Foxboro OPC server, Commercial)

Manual

Description

**Manual
number**

Human-Machine Interfaces (User Guide) _____ 585116 (85985-E0)

Specifications

Parameter	Value
Computer Requirements	A currently available personal computer running under one of the following operating systems: Windows® 7 or Windows® 8.

FactoryTalk View ME Studio (Commercial) (Optional) 588385 (46968-A0)

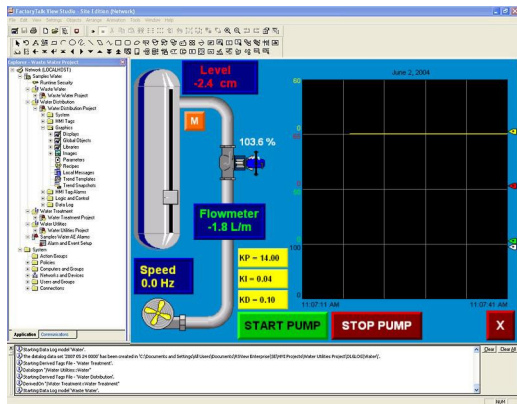

FactoryTalk View is a Windows-based application suite, produced by Rockwell Software, which simplifies the creation of graphic human-machine interfaces (HMI), such as operator interface solutions, to monitor and control machines and small processes. This versatile suite is compatible with a wide array of devices, including PLCs and Foxboro controllers, and constitutes a distributed control system development solution of choice.

HMI applications are developed and edited using FactoryTalk View Studio, which also has limited runtime capabilities to test your interface. A completed application can be loaded directly on a Touch Screen Graphic Terminal, Model 5922 or 46973, as it includes a built-in runtime software. Your applications can also

be designed to run on a computer, but doing so requires the purchase of FactoryTalk View Machine Edition Station Runtime.

A bundle (Model 46968-1 or -B) consisting of FactoryTalk View Studio and a Foxboro OPC server is available to enable communication and data exchange between a Foxboro controller (Model 46960) and a computer.

Available versions:

- 46968-0 FactoryTalk View ME Studio (Educational)
- 46968-1 FactoryTalk View ME Studio (with Foxboro OPC server, Educational)
- 46968-2 FactoryTalk View ME Station (Educational)
- 46968-3 FactoryTalk View ME Station (with Foxboro OPC server, Educational)
- 46968-A FactoryTalk View ME Studio (Commercial)
- 46968-B FactoryTalk View ME Studio (with Foxboro OPC Server, Commercial)
- 46968-C FactoryTalk View ME Station (Commercial)
- 46968-D FactoryTalk View ME Station (with Foxboro OPC server, Commercial)

Manual

Description

Manual number

Human-Machine Interfaces (User Guide) _____ 585116 (85985-E0)

Specifications

Parameter	Value
Computer Requirements	A currently available personal computer running under one of the following operating systems: Windows® 7 or Windows® 8.

FactoryTalk View ME Station (Commercial) (Optional) 588390 (46968-C0)

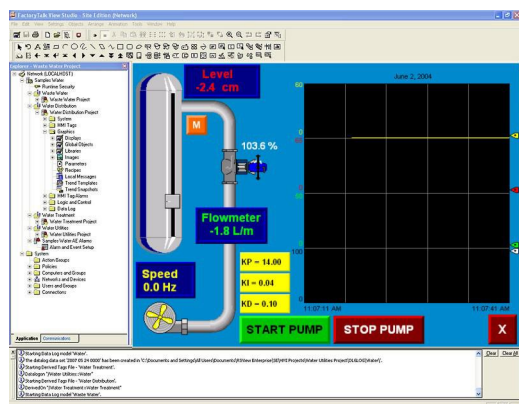

FactoryTalk View is a Windows-based application suite, produced by Rockwell Software, which simplifies the creation of graphic human-machine interfaces (HMI), such as operator interface solutions, to monitor and control machines and small processes. This versatile suite is compatible with a wide array of devices, including PLCs and Foxboro controllers, and constitutes a distributed control system development solution of choice.

HMI applications are developed and edited using FactoryTalk View Studio, which also has limited runtime capabilities to test your interface. A completed application can be loaded directly on a Touch Screen Graphic Terminal, Model 5922 or 46973, as it includes a built-in runtime software. Your applications can also

be designed to run on a computer, but doing so requires the purchase of FactoryTalk View Machine Edition Station Runtime.

A bundle (Model 46968-1 or -B) consisting of FactoryTalk View Studio and a Foxboro OPC server is available to enable communication and data exchange between a Foxboro controller (Model 46960) and a computer.

Available versions:

- 46968-0 FactoryTalk View ME Studio (Educational)
- 46968-1 FactoryTalk View ME Studio (with Foxboro OPC server, Educational)
- 46968-2 FactoryTalk View ME Station (Educational)
- 46968-3 FactoryTalk View ME Station (with Foxboro OPC server, Educational)
- 46968-A FactoryTalk View ME Studio (Commercial)
- 46968-B FactoryTalk View ME Studio (with Foxboro OPC Server, Commercial)
- 46968-C FactoryTalk View ME Station (Commercial)
- 46968-D FactoryTalk View ME Station (with Foxboro OPC server, Commercial)

Manual

Description

**Manual
number**

Human-Machine Interfaces (User Guide) _____ 585116 (85985-E0)

Specifications

Parameter	Value
Computer Requirements	A currently available personal computer running under one of the following operating systems: Windows® 7 or Windows® 8.

Step 7 professional and WinCC Advanced, 6 users (perpetual) + 20 Students (1 year), Educational (Optional) 8164650 (81646-50)



Trainer Package V17 STEP 7 Professional, Safety, WinCC Advanced and Unified Engineering

- STEP 7 Professional, Safety, WinCC Advanced and Unified Engineering, RT and Options, CFC, DCC, SiVArc, Test Suite, SIRIUS, Multiuser, Teamcenter Gateway, Cloud Connector; Target, ODK, PRODIAG, OPC UA, PLCSIM Advanced, Startdrive Advanced

- 6 x software license unlimited

- 20 x trial license for 365 days

- Software on DVD or Download
- License key on USB flash drive
- 9 languages: de,en,zh included, fr,es,it,ru,ja,ko as download
- Executable in Windows 10
- For configuring of SIMATIC S7- 1500/1200/300/400/WinAC, SIMATIC Panels

Technical changes are possible.

Special license rules apply for schools and educational institutes in the commercial sector.

Step 7 professional and WinCC Advanced, 20 Students (1 year), Educational (Optional) 8164652 (81646-52)



Trainer Package V17 STEP 7 Professional, Safety, WinCC Advanced and Unified Engineering

- STEP 7 Professional, Safety, WinCC Advanced and Unified Engineering, RT and options, CFC, Test Suite, Multiuser, PLCSIM Advanced, Target, ODK

- 20 x trial license for 365 days

- Software on DVD or Download

- License key on USB flash drive

- 9 languages: de,en,zh included, fr,es,it,ru,ja,ko as download
- Executable in Windows 10
- For configuring of SIMATIC S7- 1500/1200/300/400/WinAC, SIMATIC Panels

Technical changes are possible.

Special license rules apply for schools and educational institutes in the commercial sector.

Reflecting the commitment of Festo Didactic to high quality standards in product, design, development, production, installation, and service, our manufacturing and distribution facility has received the ISO 9001 certification.

Festo Didactic reserves the right to make product improvements at any time and without notice and is not responsible for typographical errors. Festo Didactic recognizes all product names used herein as trademarks or registered trademarks of their respective holders. © Festo Didactic Inc. 2024. All rights reserved.

Festo Didactic SE

Rechbergstrasse 3
73770 Denkendorf
Germany

P. +49(0)711/3467-0
F. +49(0)711/347-54-88500

Festo Didactic Inc.

607 Industrial Way West
Eatontown, NJ 07724
United States

P. +1-732-938-2000
F. +1-732-774-8573

Festo Didactic Ltée/Ltd

675 rue du Carbone
Québec QC G2N 2K7
Canada

P. +1-418-849-1000
F. +1-418-849-1666

www.labvolt.com

www.festo-didactic.com