



Case Study: Electric Power Transmission

Building power transmission and distribution in your classroom: Lab-Volt's 8055 enabled flexible training solutions for the Bonneville Power Administration.

Lab-Volt's Electric Power and Controls system has been a hallmark for electrical power training for over four decades. A modular approach to the study of basic and advanced electric power technology provides instructors the flexibility to customize their own training needs. Dedication to the highest quality product provides instructors and institutions with decades of reliable performance. Lab-Volt's EMS provides the means for solving the needs of our academic and industry partners through providing the most flexible, durable, and educationally relevant solution to Electric Power and Controls training.

Profile: Bonneville Power Administration (BPA) is a federal agency that markets wholesale electricity and transmission to the Pacific Northwest. BPA operates one of the most reliable transmission grids in the world, marketing hydroelectric power from 31 federally owned dams as well as non-federal hydroelectric, nuclear, and wind energy generation facilities.

Situation: Training new technicians for work on a power transmission system ultimately requires many hours in the field. But the technician is also subjected to the theory of how the power system works through a rigorous program in the classroom. In order to maximize the effectiveness of this classroom portion of their training, BPA needed to bring realistic, hands-on training, into the classroom.

Solution: BPA purchased six of Lab-Volt's Electric Power Transmission Training Systems (Model 8055). The 8055 system allowed BPA to bring their power distribution system safely and effectively into the classroom. Technicians could now observe and analyze electrical phenomena that previously required advanced-level mathematics.



Power Generation and Synchronization

Results: Lab-Volt's 8055 has provided BPA with more than 15 years of reliable service. Instructors at BPA have gone well beyond the power transmission experiments provided with the system. Due to the modular design of Lab-Volt's Electric Power and Controls systems, BPA has been able to create power transmission scenarios utilizing multiple 8055 systems cascaded together. Shown in the photo is BPA instructor Kurt Dobin demonstrating a scenario where a BPA customer's alternators are being synchronized prior to connection to the transmission grid. Three racks of 8055 equipment are utilized in the demonstration (See reverse side for wiring diagram).

This scenario allows BPA instructors to faithfully reproduce a customer's process and model its effect on the transmission system. This type of custom application is a powerful example of the real-world utility of Lab-Volt's equipment, enabled through the modularity and flexibility of the EMS product and the creativity of fellow educators.

BONNEVILLE POWER ADMINISTRATION



BPA



For information about any Lab-Volt technical or technology training system
Call toll-free in the U.S. and Canada 1-800-LABVOLT
or visit www.labvolt.com

Power Generation and Synchronization

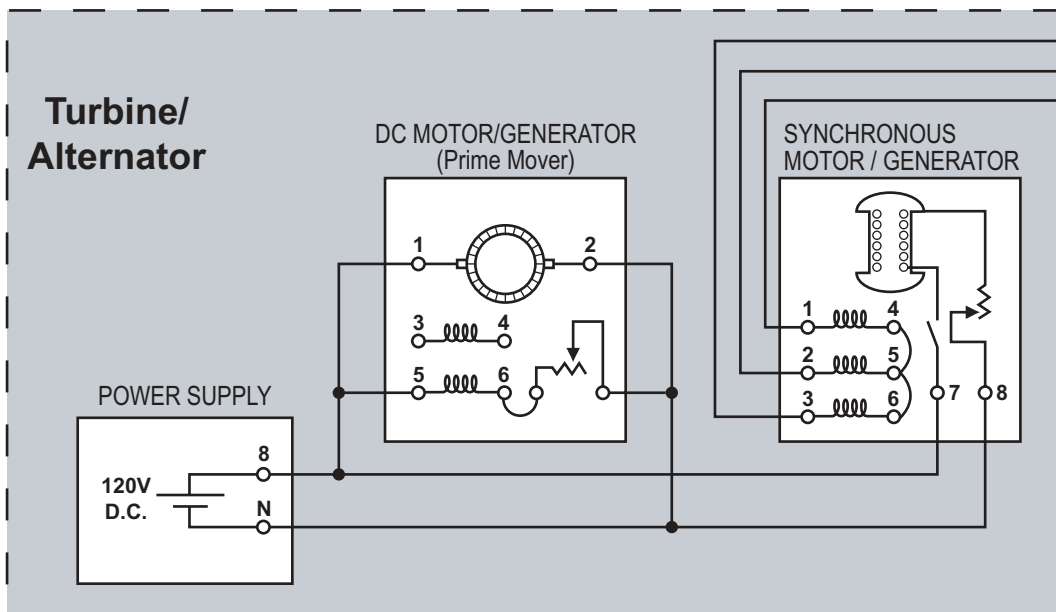
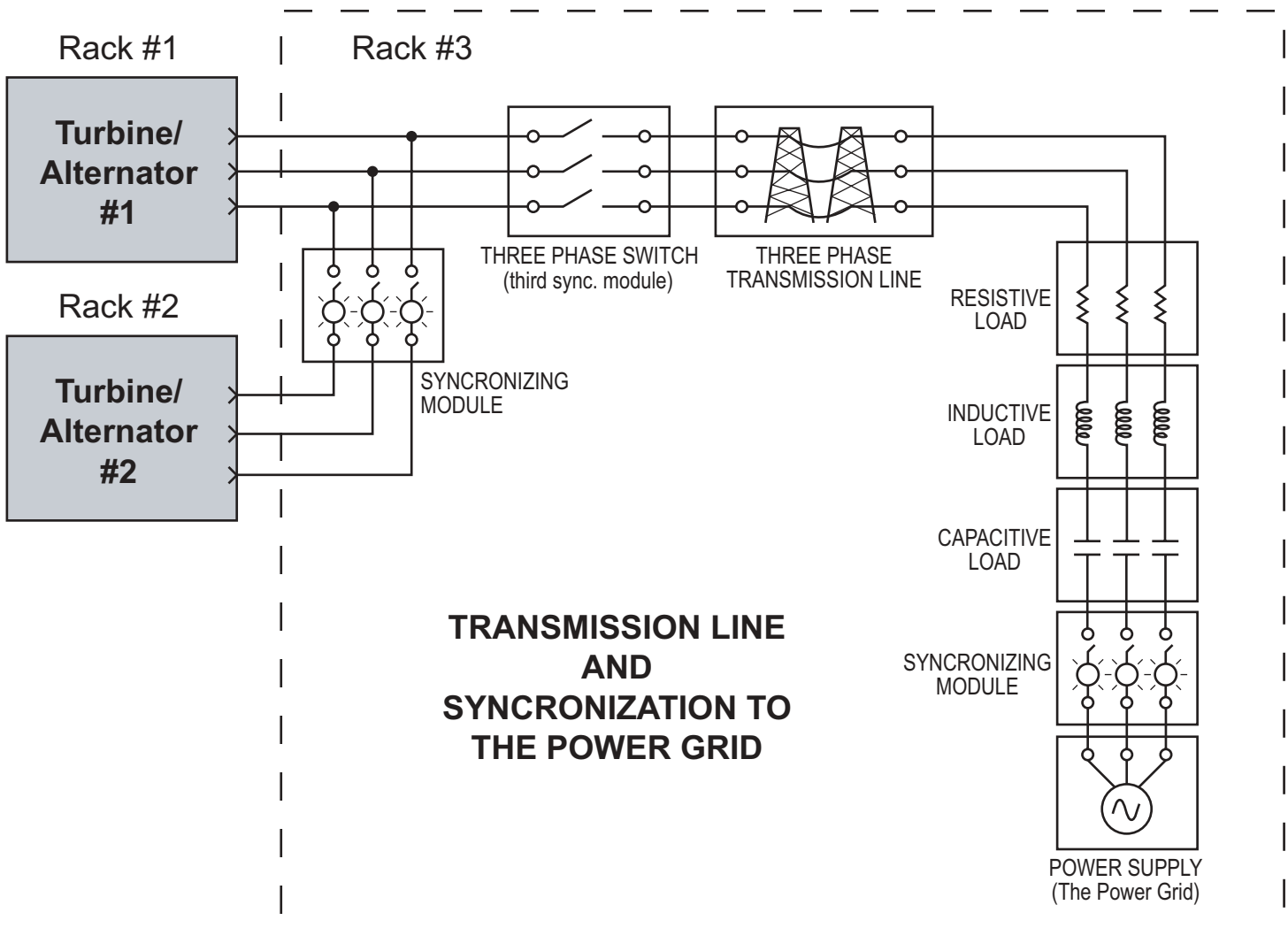

Equipment Required:

- (2) DC Motor / Generator 8211
- (2) Sync Motor / Generator 8241
- (2) Resistive Load 8311
- (2) Inductive Load 8321
- (2) Capacitive Load 8331
- (1) Transmission Line 8370
- (2) DC Voltmeter/Ammeter 8412
- (3) AC Ammeter 8425
- (2) AC Voltmeter 8426
- (3) Watt/Var Meter 8446
- (3) Synchronizing Module 8621
- (3) Power Supply 8821